

19. Camshaft S103092

A: REMOVAL S103092A18

- 1) Remove V-belt. <Ref. to ME(H4)-43 INSTALLATION, V-belt.>
- 2) Remove crankshaft pulley. <Ref. to ME(H4)-44 REMOVAL, Crankshaft Pulley.>
- 3) Remove belt cover. <Ref. to ME(H4)-45 REMOVAL, Belt Cover.>
- 4) Remove timing belt assembly. <Ref. to ME(H4)-46 REMOVAL, Timing Belt Assembly.>
- 5) Remove camshaft sprocket. <Ref. to ME(H4)-51 REMOVAL, Camshaft Sprocket.>
- 6) Remove crankshaft sprocket. <Ref. to ME(H4)-52 REMOVAL, Crankshaft Sprocket.>
- 7) Remove belt cover No. 2 (LH).
- 8) Remove belt cover No. 2 (RH).

CAUTION:

Do not damage or lose the seal rubber when removing belt covers.

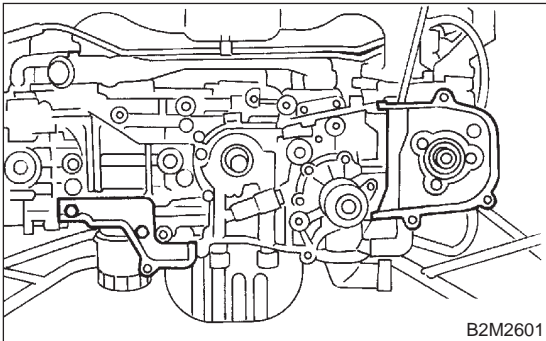

- 9) Remove tensioner bracket.

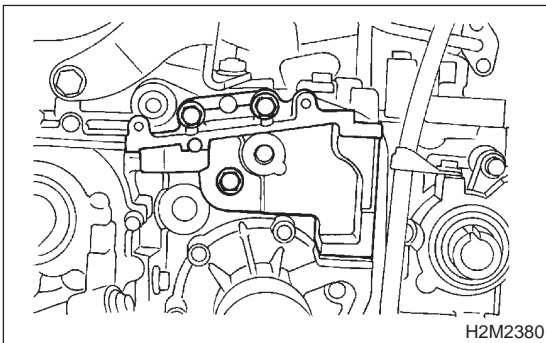

- 10) Remove camshaft position sensor support. (LH side only)
- 11) Remove oil level gauge guide. (LH side only)
- 12) Remove valve rocker assembly. <Ref. to ME(H4)-53 REMOVAL, Valve Rocker Assembly.>
- 13) Remove camshaft cap.

- (1) Remove bolts (a) through (b) in alphabetical sequence.

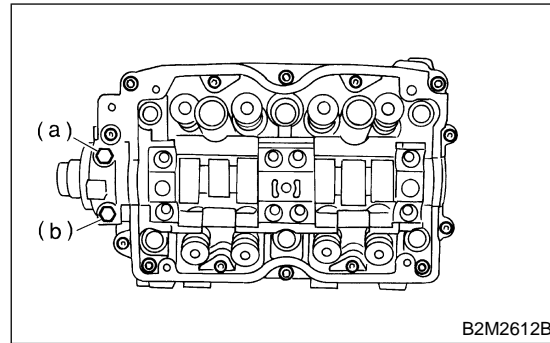

- (2) Equally loosen bolts (c) through (j) all the way in alphabetical sequence.

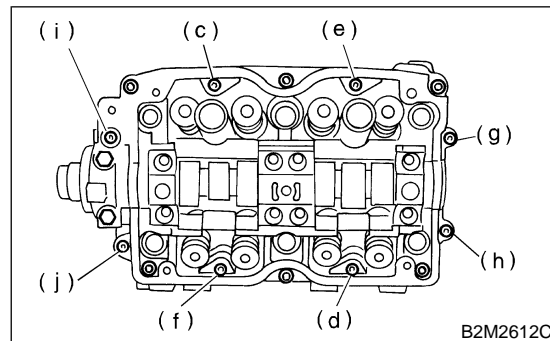

- (3) Remove bolts (k) through (p) in alphabetical sequence using ST.
- ST 499497000 TORX PLUS

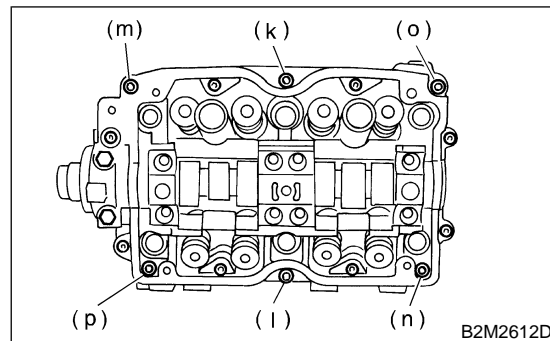

- (4) Remove camshaft cap.

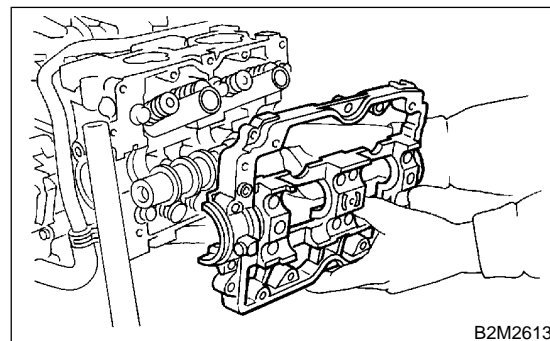

- 14) Remove camshaft.
- 15) Remove oil seal.

CAMSHAFT

Mechanical

16) Remove plug from rear side of camshaft.

CAUTION:

- Do not remove oil seal unless necessary.
- Do not scratch journal surface when removing oil seal.

B: INSTALLATION

S103092A11

- 1) Apply a coat of engine oil to camshaft journals and install camshaft.
- 2) Install camshaft cap.
 - (1) Apply liquid gasket on the around of camshaft cap.

Liquid gasket:

THREE BOND 1280B
P/N K0877YA018

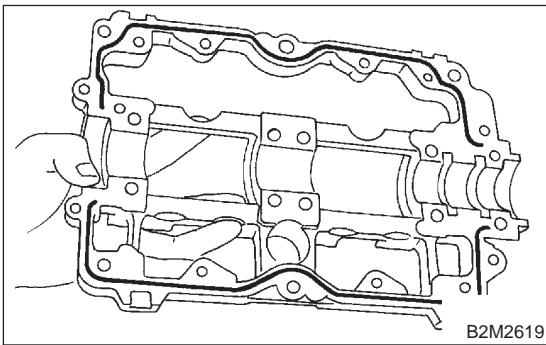

B2M2619

NOTE:

Apply a coat of 3 mm (0.12 in) dia. liquid gasket along edge of cam cap mating surface.

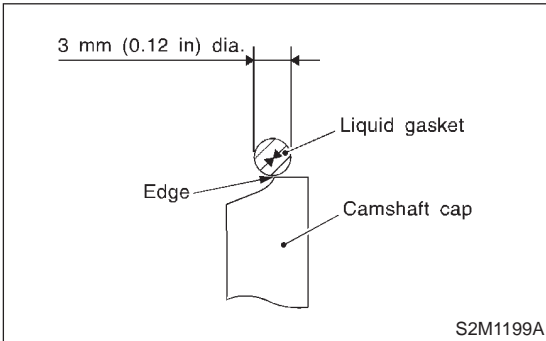

S2M1199A

(2) Temporarily tighten bolts (g) through (j) in alphabetical sequence.

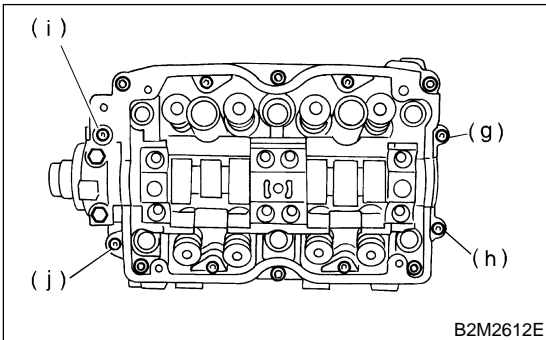

B2M2612E

(3) Install valve rocker assembly.

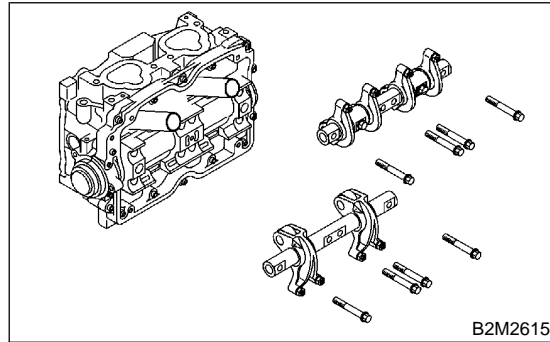

B2M2615

(4) Tighten bolts (a) through (h) in alphabetical sequence.

Tightening torque:

25 N·m (2.5 kgf-m, 18.1 ft-lb)

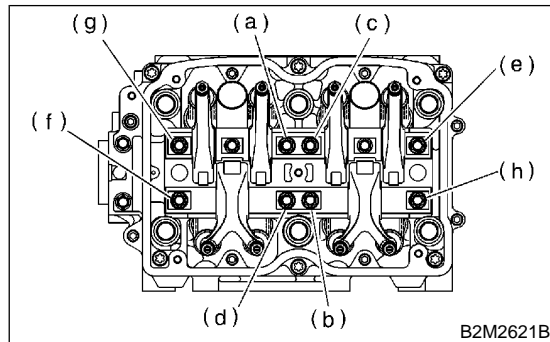

B2M2621B

(5) Tighten TORX bolts (i) through (n) in alphabetical sequence using ST.

ST 499427000 TORX PLUS

Tightening torque:

18 N·m (1.8 kgf-m, 13.0 ft-lb)

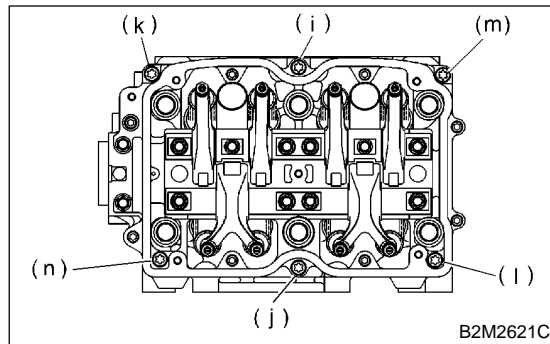

B2M2621C

(6) Tighten bolts (o) through (v) in alphabetical sequence.

Tightening torque:

10 N·m (1.0 kgf-m, 7.2 ft-lb)

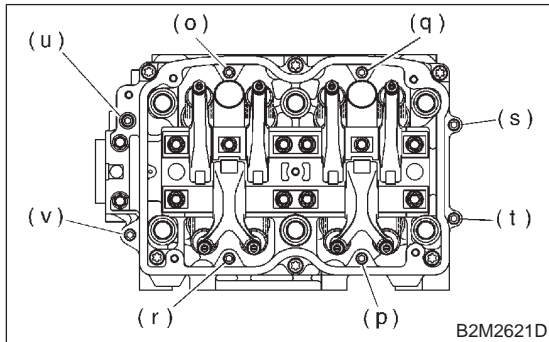

(7) Tighten bolts (w) through (x) in alphabetical sequence.

Tightening torque:

10 N·m (1.0 kgf-m, 7.2 ft-lb)

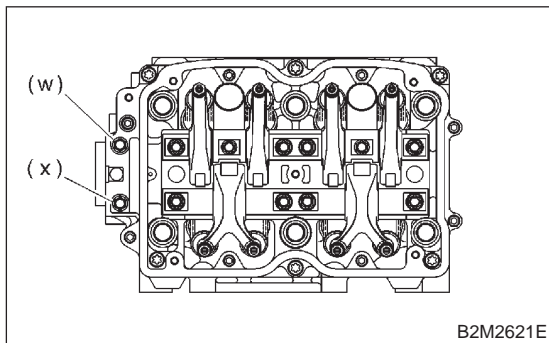

3) Apply a coat of grease to oil seal lips and install oil seal (A) on camshaft using ST1 and ST2.

CAUTION:

Use a new oil seal.

- ST1 499597000 OIL SEAL GUIDE
- ST2 499587500 OIL SEAL INSTALLER

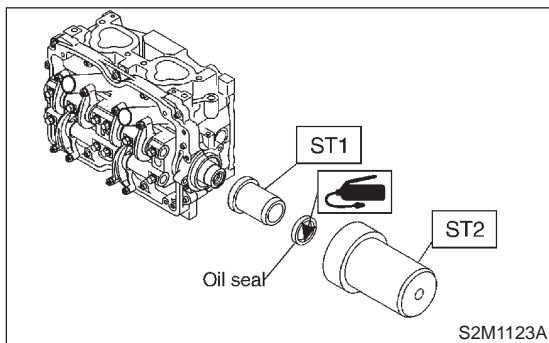

4) Install plug using ST.

- ST 499587700 OIL SEAL INSTALLER

5) Adjust the valve clearance. <Ref. to ME(H4)-31 ADJUSTMENT, Valve Clearance.>

6) Install rocker cover and connect PCV hose.

7) Install oil level gauge guide. (LH side only)

8) Install camshaft position sensor support. (LH side only)

9) Install tensioner bracket.

Tightening torque:

25 N·m (2.5 kgf-m, 18.1 ft-lb)

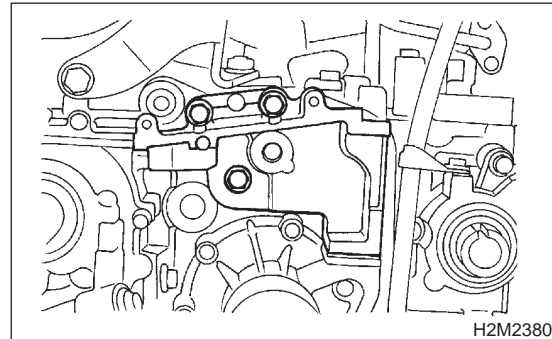

10) Install belt cover No. 2 (RH).

Tightening torque:

5 N·m (0.5 kgf-m, 3.6 ft-lb)

11) Install belt cover No. 2 (LH).

Tightening torque:

5 N·m (0.5 kgf-m, 3.6 ft-lb)

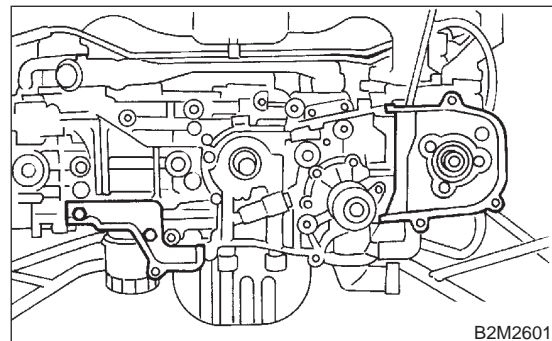

12) Install timing belt assembly. <Ref. to ME(H4)-47 INSTALLATION, Timing Belt Assembly.>

13) Install belt cover. <Ref. to ME(H4)-45 INSTALLATION, Belt Cover.>

14) Install crankshaft pulley. <Ref. to ME(H4)-44 INSTALLATION, Crankshaft Pulley.>

15) Install V-belt. <Ref. to ME(H4)-43 INSTALLATION, V-belt.>

CAMSHAFT

Mechanical

C: INSPECTION S103092A10

1. CAMSHAFT S103092A1001

1) Measure the bend, and repair or replace if necessary.

Limit:

0.025 mm (0.0010 in)

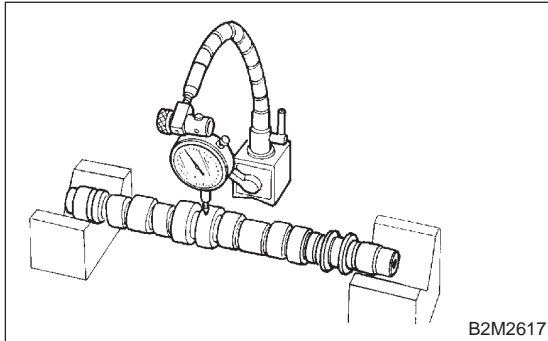

2) Check journal for damage and wear. Replace if faulty.

3) Measure outside diameter of camshaft journal and inside diameter of cylinder head journal, and determine the difference between the two (= oil clearance). If oil clearance exceeds specifications, replace camshaft or cylinder head as necessary.

Unit: mm (in)		
Clearance at journal	Standard	0.055 — 0.090 (0.0022 — 0.0035)
	Limit	0.10 (0.0039)
Camshaft journal O.D.		31.928 — 31.945 (1.2570 — 1.2577)
Journal hole I.D.		32.000 — 32.018 (1.2598 — 1.2605)

4) Check cam face condition; remove minor faults by grinding with oil stone. Measure the cam height H; replace if the limit has been exceeded.

Cam height: H

Unit: mm (in)		
Intake	STD	39.485 — 39.585 (1.5545 — 1.5585)
	Limit	39.385 (1.5506)
Exhaust	STD	39.257 — 39.357 (1.5455 — 1.5495)
	Limit	39.157 (1.5416)

Cam base circle diameter A:
IN: 34.00 mm (1.3386 in)
EX: 34.00 mm (1.3386 in)

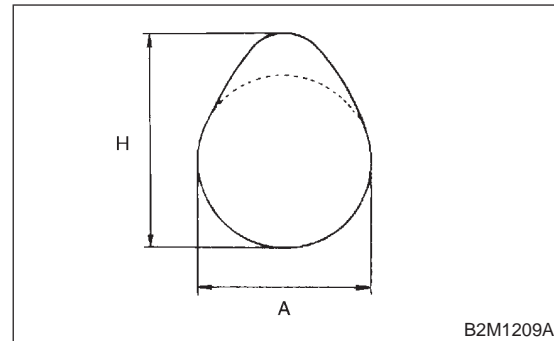

2. CAMSHAFT SUPPORT S103092A1002

Measure the thrust clearance of camshaft with dial gauge. If the clearance exceeds the limit, replace camshaft support.

Standard:

0.030 — 0.090 mm (0.0012 — 0.0035 in)

Limit:

0.10 mm (0.0039 in)

