

## 2. Starter S109012

### A: REMOVAL S109012A18

- 1) Disconnect battery ground cable.

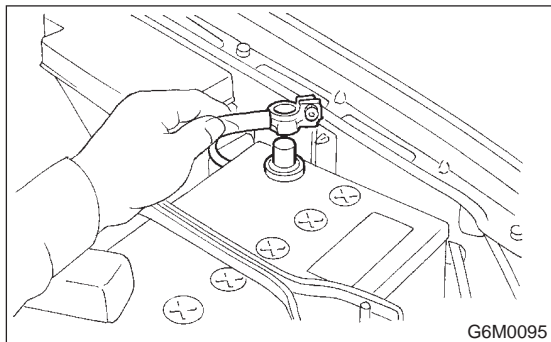

- 2) Disconnect connector from intake air temperature sensor. (MT vehicles)

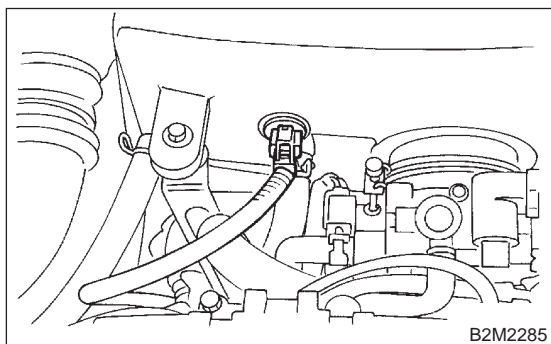

- 3) Remove air cleaner case.

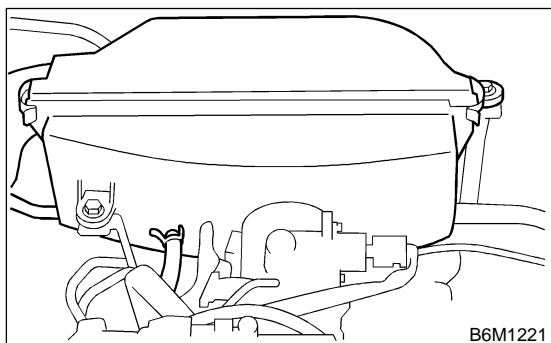

- 4) Remove air cleaner case stay.

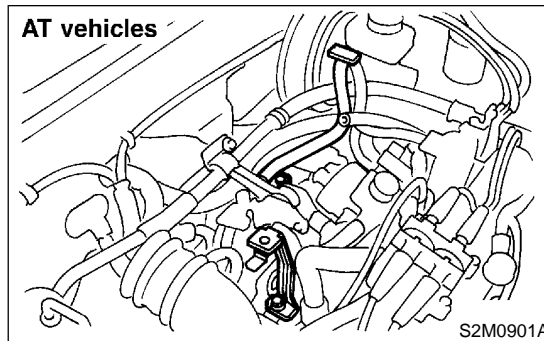
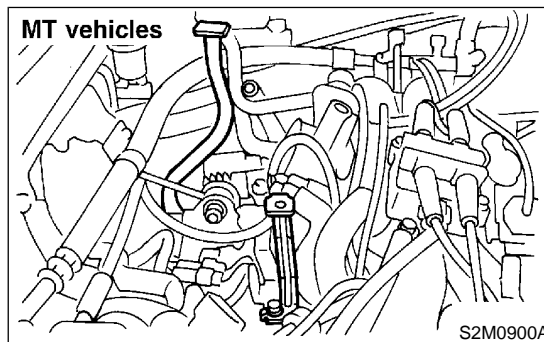

- 5) Disconnect connector and terminal from starter.

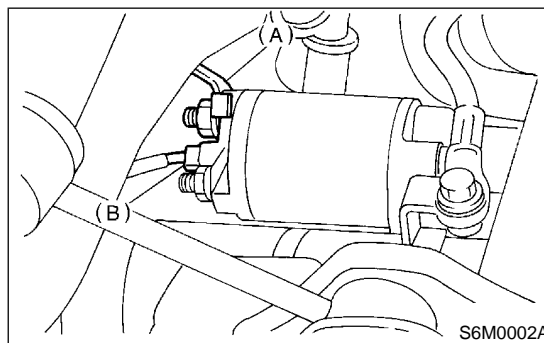

- (A) Terminal
- (B) Connector

- 6) Remove starter from transmission.

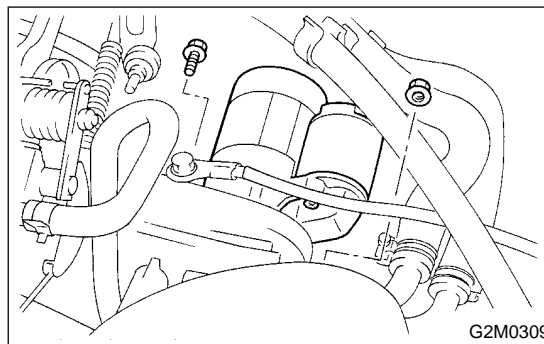

# STARTER

Starting/Charging Systems

## B: INSTALLATION S109012A11

Install in the reverse order of removal.

**Tightening torque:**  
**50 N·m (5.1 kgf·m, 37 ft·lb)**

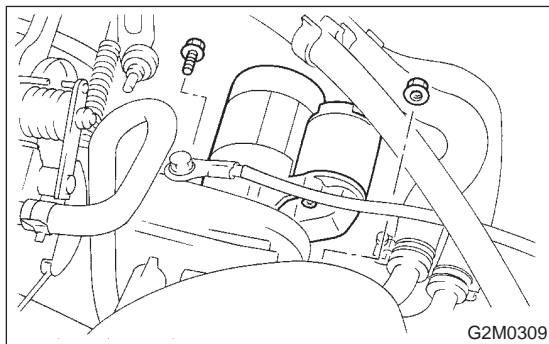

## C: DISASSEMBLY S109012A06

1) Disconnect lead wire from magnetic switch.

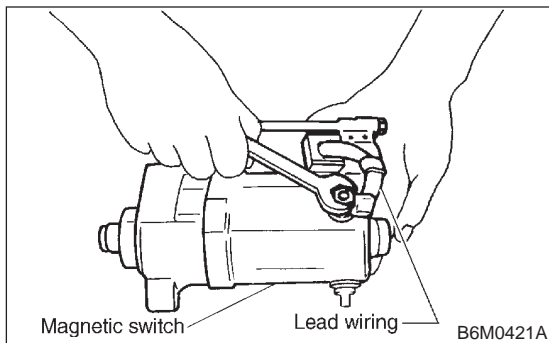

2) Remove through-bolts from end frame.

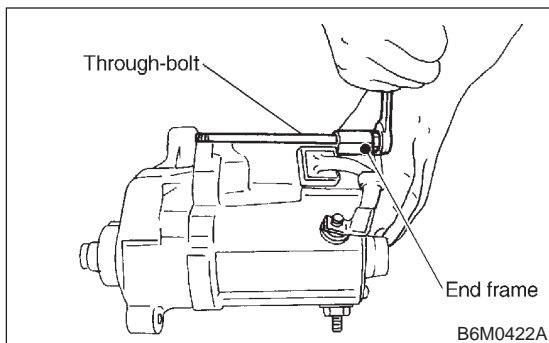

3) Remove yoke from magnetic switch.

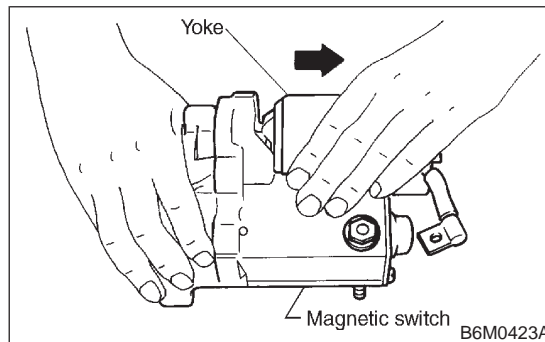

4) Remove screws securing end frame to brush holder.

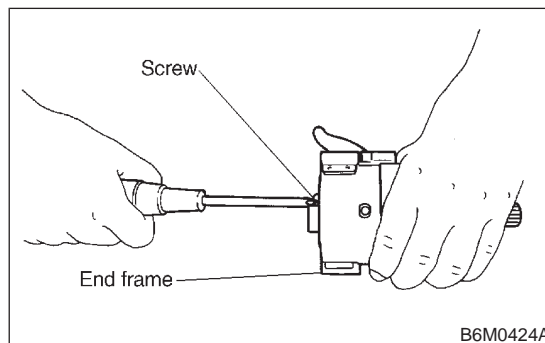

5) Separate yoke from end frame.

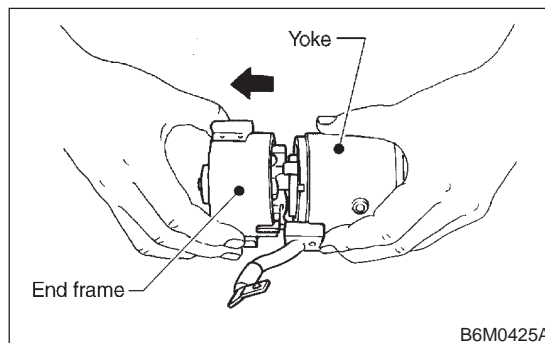

6) Remove brush by lifting up positive (+) side brush spring using long-nose pliers.

**CAUTION:**  
**Be careful not to damage brush and commutator.**

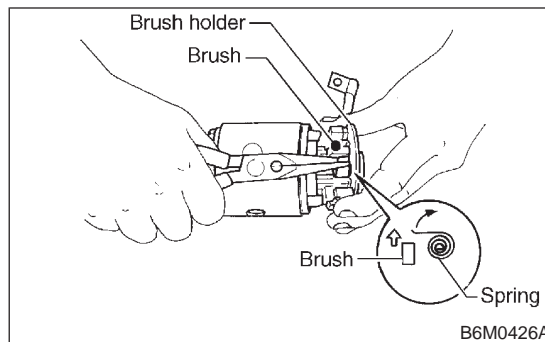

SC(H4)-8

7) Remove armature from yoke.

**CAUTION:**

Be careful not to drop armature.

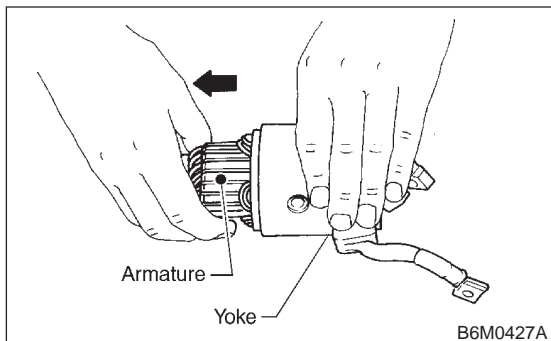

8) Remove screws securing magnetic switch to housing.

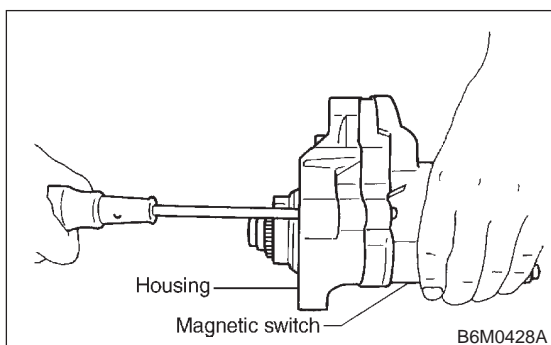

9) Remove housing from magnetic switch.

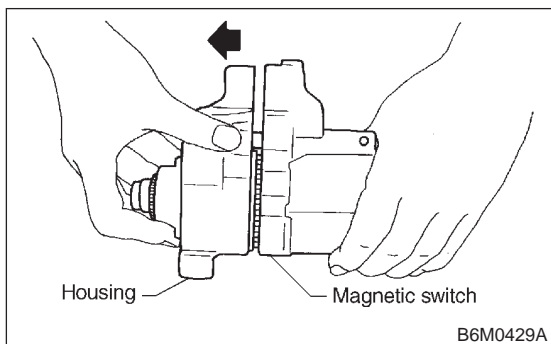

10) Remove clutch from housing.

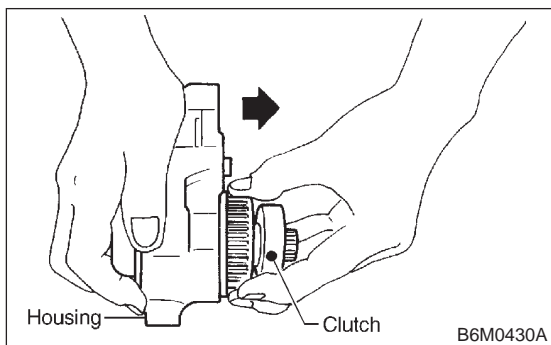

11) Take out steel ball from clutch.

**CAUTION:**

Be careful not to lose steel ball.

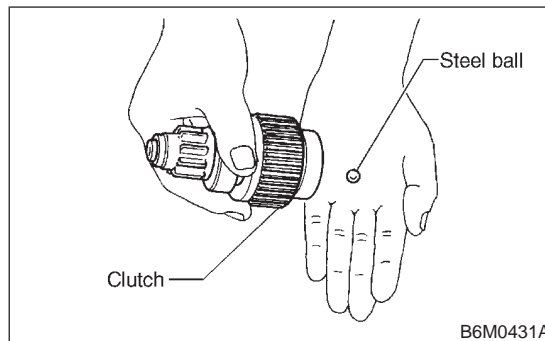

12) Remove idle gear from housing.

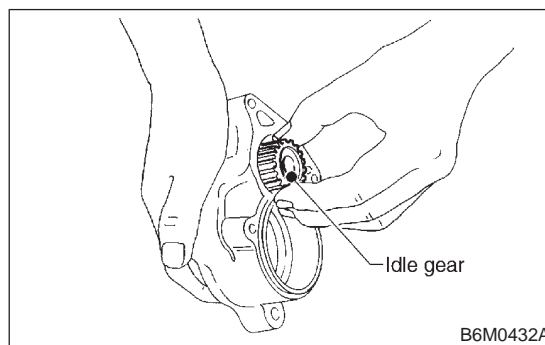

13) Remove retainer and roller from housing.

**CAUTION:**

Be careful not to drop retainer and roller.

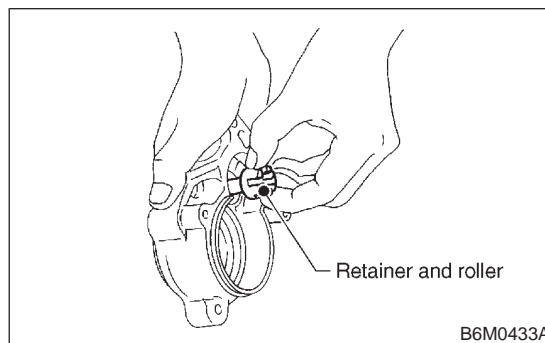

14) Remove coil spring from magnetic switch.

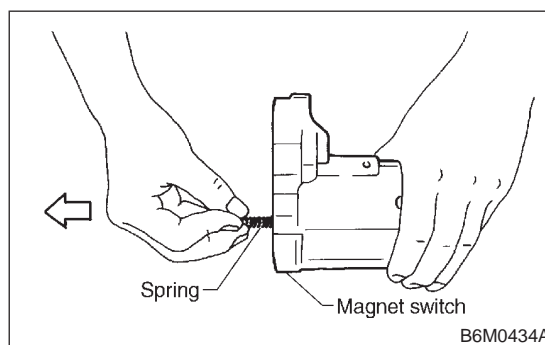

# STARTER

Starting/Charging Systems

## D: ASSEMBLY S109012A02

Assemble in the reverse order of disassembly. Observe the following:

1) Before assembling, lubricate disassembled parts at the points shown in "COMPONENT PARTS". <Ref. to SC(H4)-3 STARTER, COMPONENT, General Description.>

**Grease:**

**ESSO BEACON 325**  
**SHELL ALVANIA GREASE RA**  
**or equivalent**

2) Assembling magnetic switch, clutch, and housing

To assemble, first install clutch to magnetic switch, then install idle gear, and finally install clutch.

**CAUTION:**

- Do not forget to install steel ball and coil spring to clutch.
- Attach bearing to idle gear beforehand.

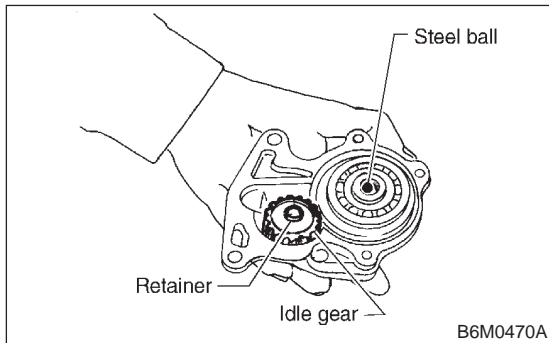

3) Installing armature to yoke

**CAUTION:**

Do not forget to put felt washer on armature shaft bearing.

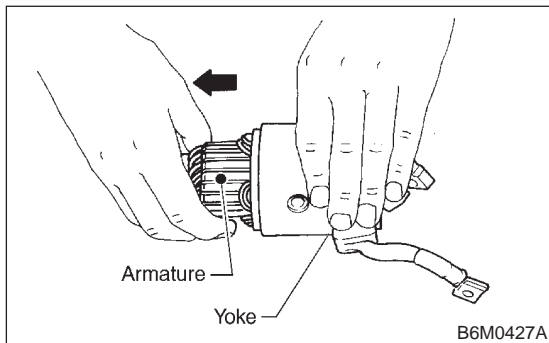

4) Installing brushes

Assemble brush holder to yoke as shown, then assemble two yoke-side brushes to brush holder.

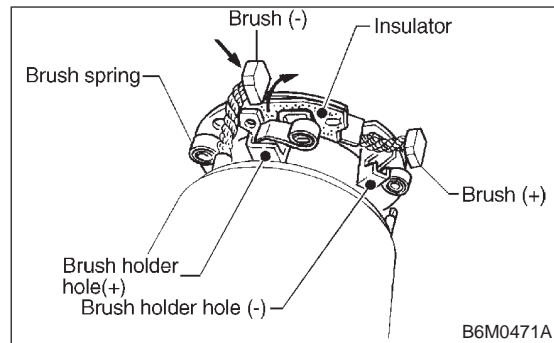

5) Installing end frame

When assembling end frame to yoke, align notched portion of end frame with lead wire grommet.

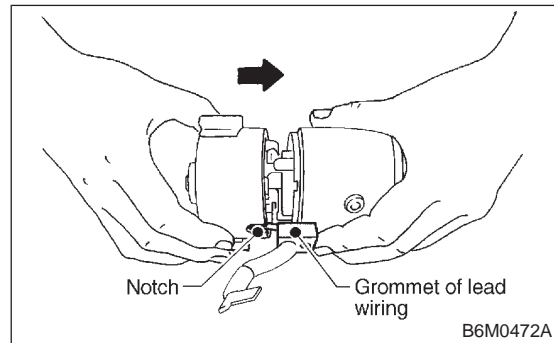

6) Installing yoke

When installing yoke to magnetic switch, align notch of yoke with protrusion of magnetic switch.

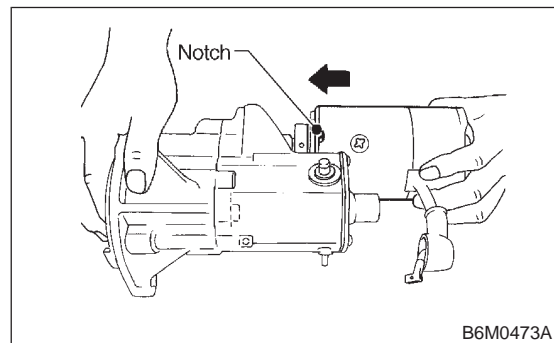

## E: INSPECTION S109012A10

### 1. ARMATURE S109012A1001

1) Check commutator for any sign of burns or rough surfaces or stepped wear. If wear is of a minor nature, correct it by using sand paper.

2) Run-out test

Check the commutator run-out and replace if it exceeds the limit.

#### Commutator run-out:

##### Standard

**0.02 mm (0.0008 in), or less**

##### Service limit

**Less than 0.05 mm (0.0020 in)**

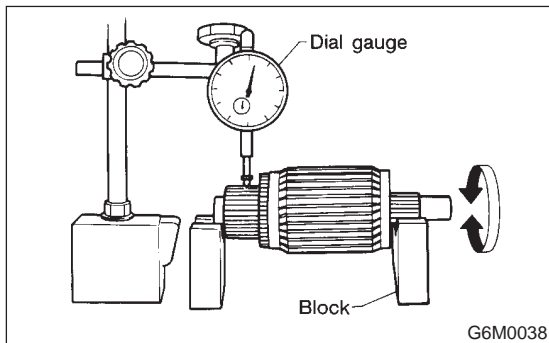

3) Depth of segment mold

Check the depth of segment mold.

#### Depth of segment mold:

**0.6 mm (0.024 in)**

##### Limit

**0.2 mm (0.008 in)**

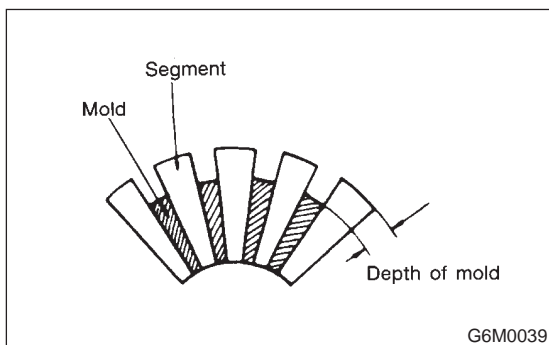

4) Armature short-circuit test

Check armature for short-circuit by placing it on growler tester. Hold a hacksaw blade against armature core while slowly rotating armature. A short-circuited armature will cause the blade to vibrate and to be attracted to core. If the hacksaw blade is attracted or vibrates, the armature, which is short-circuited, must be replaced or repaired.

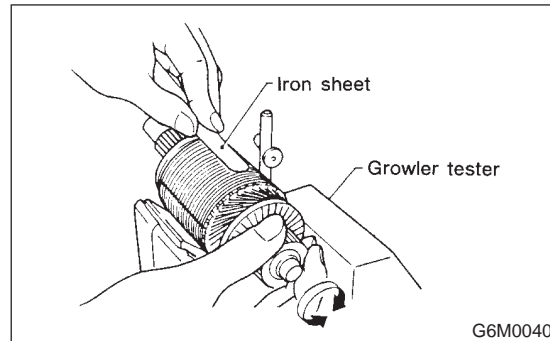

5) Armature ground test

Using circuit tester, touch one probe to the commutator segment and the other to shaft. There should be no continuity. If there is a continuity, armature is grounded.

Replace armature if it is grounded.

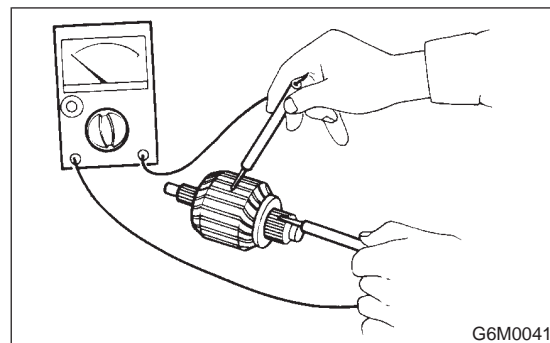

### 2. YOKE S109012A1002

Make sure pole is set in position.

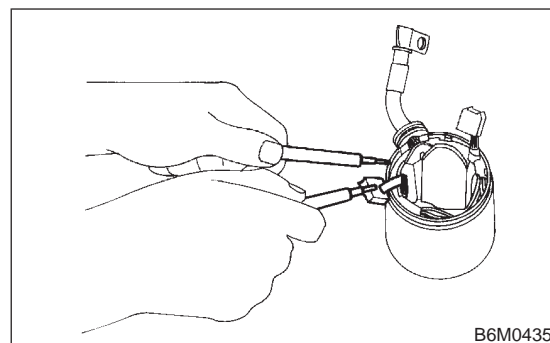

# STARTER

## 3. OVERRUNNING CLUTCH S109012A1003

Inspect teeth of pinion for wear and damage. Replace if it is damaged. Rotate pinion in direction of rotation (clockwise). It should rotate smoothly. But in opposite direction, it should be locked.

### CAUTION:

Do not clean overrunning clutch with oil to prevent grease from flowing out.

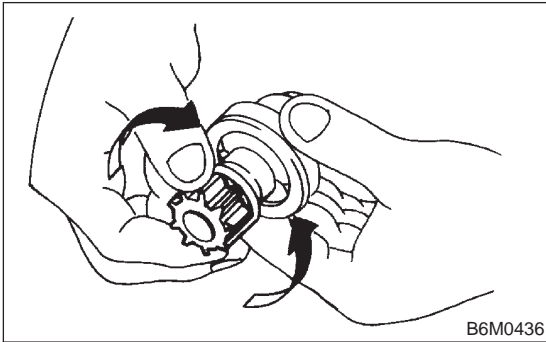

## 4. BRUSH AND BRUSH HOLDER S109012A1004

### 1) Brush length

Measure the brush length and replace if it exceeds the service limit.

Replace if abnormal wear or cracks are noticed.

### Brush length:

#### Standard

15 mm (0.59 in)

#### Service limit

10 mm (0.39 in)

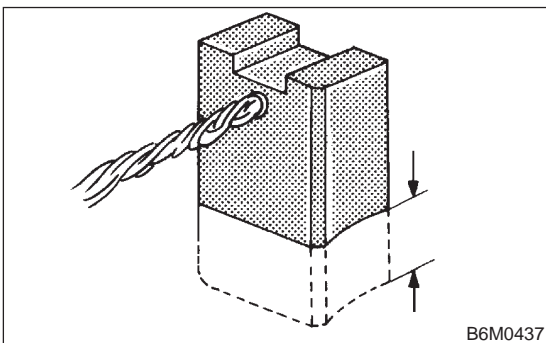

### 2) Brush movement

Be sure brush moves smoothly inside brush holder.

### 3) Insulation resistance of brush holder

Be sure there is no continuity between brush holder and its plate.

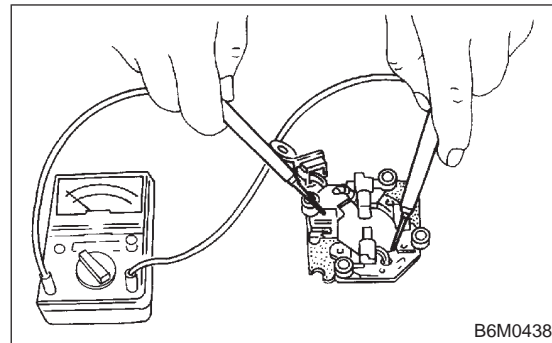

### 4) Brush spring force

Measure brush spring force with a spring scale. If it is less than the service limit, replace brush spring.

### Brush spring force:

#### Standard

18.6 N (1.9 kg, 4.2 lb) (when new)

#### Service limit

6.9 N (0.7 kg, 1.5 lb)

## 5. BEARING S109012A1005

1) Rotate bearing by hand; no binding should exist.

2) Rotate bearing rapidly; no abnormal noise should be heard.

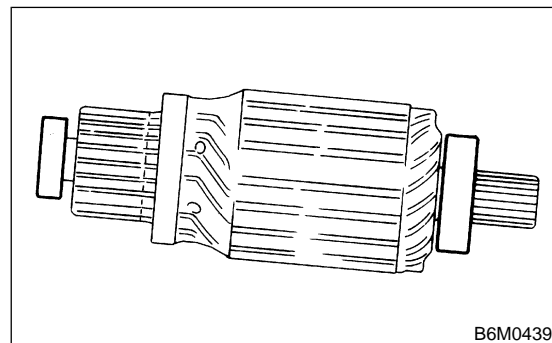

## 6. MAGNETIC SWITCH S109012A1006

### CAUTION:

- The following magnetic switch tests should be performed with specified voltage applied.
- Each test should be conducted within 3 to 5 seconds. Power to be furnished should be one-half the rated voltage.

## 1) Pull-in test

Connect two battery negative leads onto magnetic switch body and terminal C respectively. Then connect battery positive lead onto terminal 50. Pinion should extend when lead connections are made.

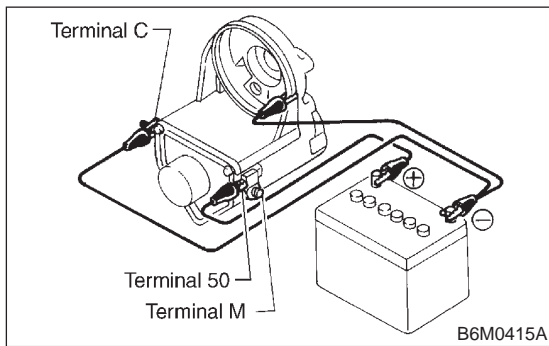

## 2) Holding-in test

Disconnect lead from terminal C with pinion extended. Pinion should be held in the extended position.

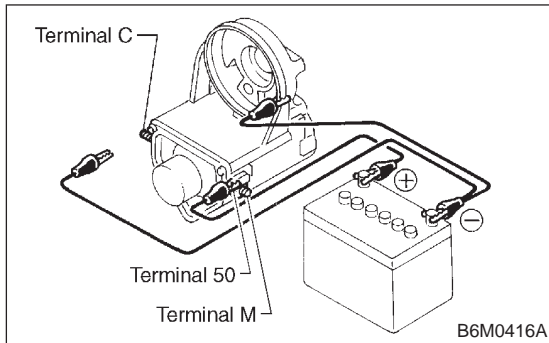

## 3) Return test

Connect two battery negative leads onto terminal 50 and onto switch body respectively. Then connect battery positive lead onto terminal C. Next, disconnect lead from terminal 50. Pinion should return immediately.

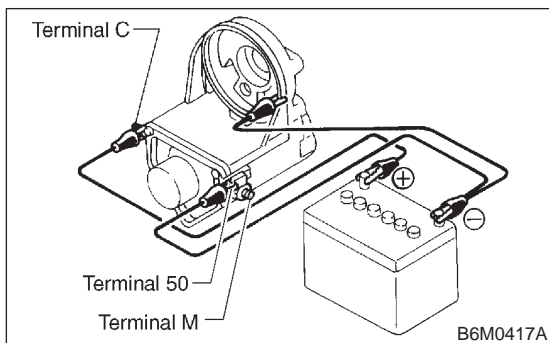

fied capacity whenever testing the starter.

The starter should be checked for the following three items:

- No-load test

Measure the maximum rotating speed and current under a no-load state.

- Load test

Measure the magnitude of current needed to generate the specified torque and rotating speed.

- Stall test

Measure the torque and current when the armature is locked.

### 1) No-load test

Run single starter under no-load state, and measure its rotating speed, voltage, and current, using the specified battery. Measured values must meet the following standards:

#### **No-load test (Standard):**

##### **Voltage/Current**

**11 V/90 A, or more**

##### **Rotating speed**

**TN128000-8311: 3,000 rpm, or more**

**TN128000-8321: 3,350 rpm, or more**

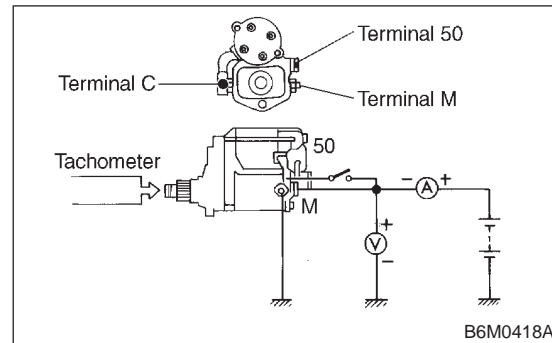

## 7. PERFORMANCE TEST S109012A1007

The starter is required to produce a large torque and high rotating speed, but these starter characteristics vary with the capacity of the battery. It is therefore important to use a battery with the speci-

# STARTER

## Starting/Charging Systems

### 2) Load test (For reference)

Perform this test to check maximum output of starter. Use test bench which is able to apply load (brake) to starter. Measure torque value and rotating speed under the specified voltage and current conditions while controlling braking force applied to starter.

#### CAUTION:

Change engagement position of overrunning clutch and make sure it is not slipping.

#### Load test (Standard):

##### TN128000-8311

**Voltage/Load**

8 V/9.8 N·m (1.0 kgf·m, 7.2 ft·lb)

**Current/Speed**

280 A max./900 rpm min.

##### TN128000-8321

**Voltage/Load**

8 V/13.7 N·m (1.4 kgf·m, 10.1 ft·lb)

**Current/Speed**

370 A, or less/880 rpm, or more

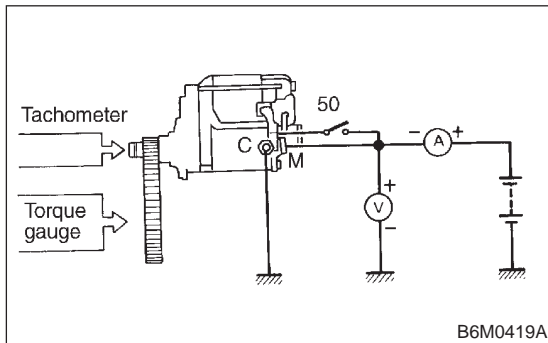

### 3) Stall test

Using the same test equipment used for load test, apply brake to lock starter armature. Then measure voltage, current, and torque values. Measured values must meet the following standard.

#### Stall test (Standard):

##### TN128000-8311

**Voltage/Current**

5 V/800 A, or less

**Torque**

27.5 N·m (2.8 kgf·m, 20.3 ft·lb) min.

##### TN128000-8321

**Voltage/Current**

5 V/1,050 A, or less

**Torque**

27.5 N·m (2.8 kgf·m, 20.3 ft·lb) min.

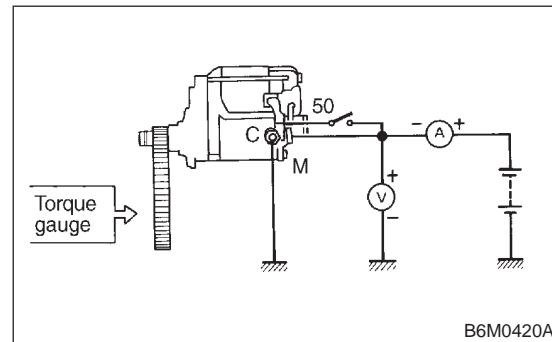

#### NOTE:

Low rotating speed or excessive current during no-load test may be attributable to high rotating resistance of starter due to improper assembling. Small current and no torque during stall test may be attributable to excessive contact resistance between brush and commutator; whereas, normal current and insufficient torque may be attributable to shorted commutator or poor insulation. Starter can be considered normal if it passes no-load and stall tests; therefore, load test may be omitted.