

## 3. Generator S109008

### A: REMOVAL S109008A18

- 1) Disconnect battery ground cable.

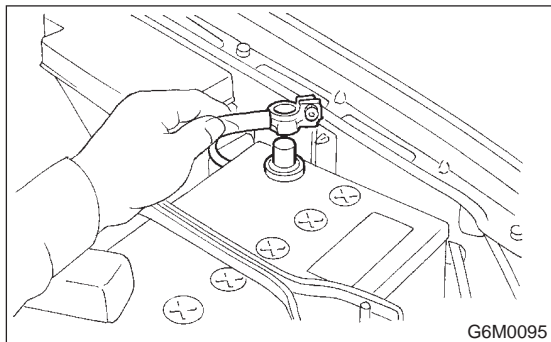

- 2) Disconnect connector and terminal from generator.

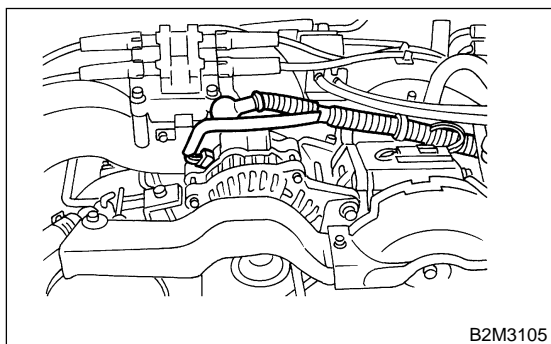

- 3) Remove V-belt cover.

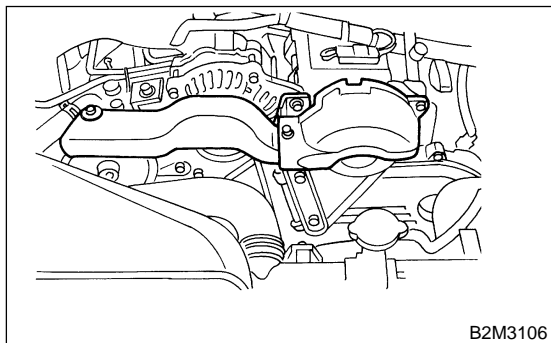

- 4) Remove front side V-belt.

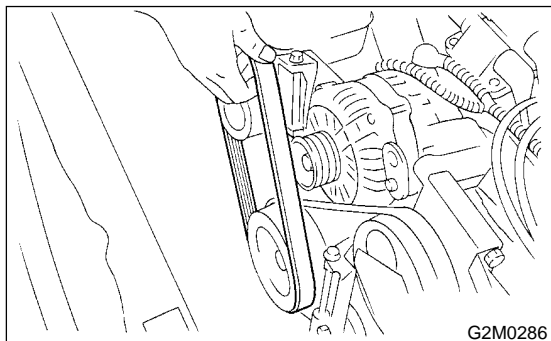

- 5) Remove bolts which install generator onto bracket.

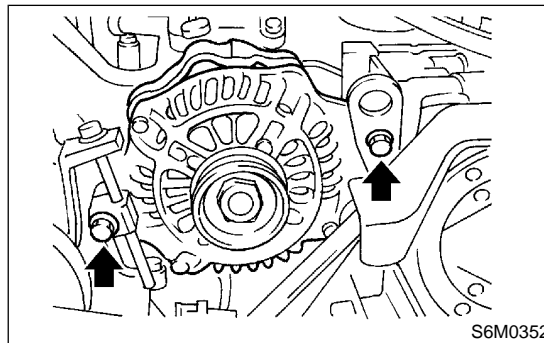

### B: INSTALLATION S109008A11

Install in the reverse order of removal.

#### CAUTION:

Check and adjust V-belt tension. <Ref. to ME(H4)-43 INSPECTION, V-belt.>

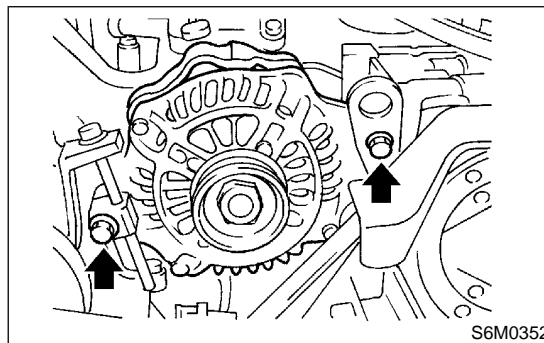

### C: DISASSEMBLY S109008A06

- 1) Heat the portion (A) of rear cover to 50°C (122°F) with heater drier.

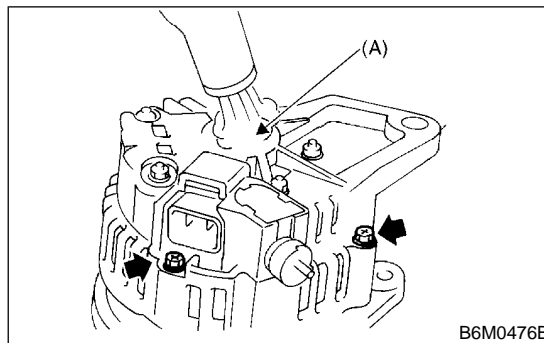

# GENERATOR

## Starting/Charging Systems

2) Remove the four through bolts. Then insert the tip of a flat-head screwdriver into the gap between the stator core and front bracket. Pry then apart to disassemble.

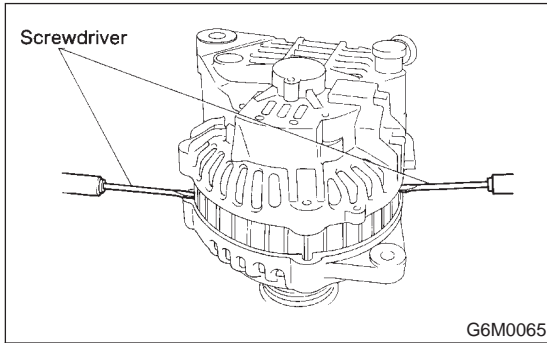

3) Hold rotor with a vise and remove pulley nut.

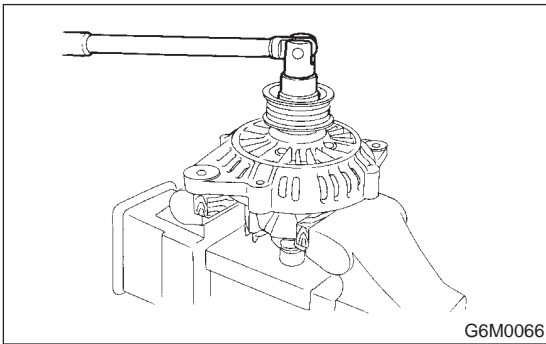

### CAUTION:

When holding rotor with vise, insert aluminum plates or wood pieces on the contact surfaces of the vise to prevent rotor from damage.

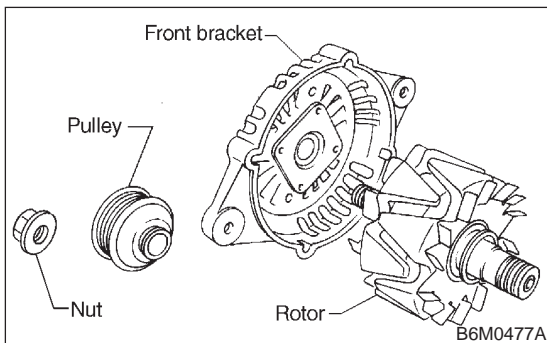

4) Remove rotor from front cover.

5) Remove three screws from front cover and then bearing retainer and ball bearing.

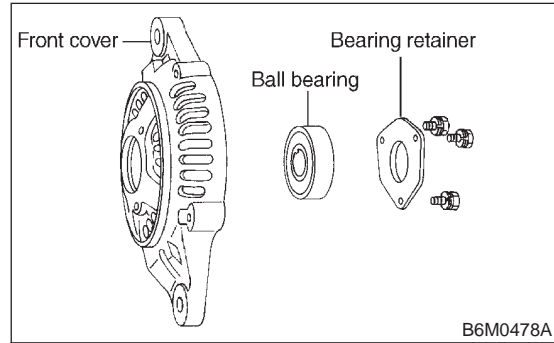

6) Remove bolt which secure battery terminal bolt, and remove rear cover. Remove nuts which secure diode plate, and remove stator and rear cover.

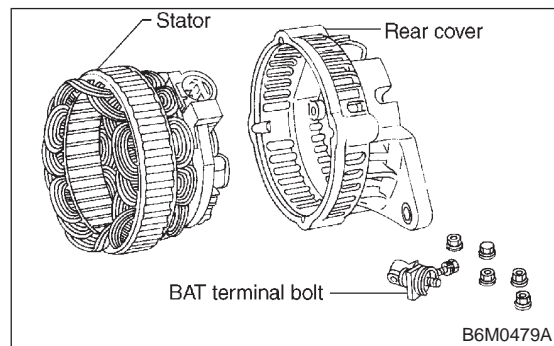

7) Separate diode plate from stator coil.

(1) Cut the connecting position (A) of stator coil to diode.

(2) Unsolder connection (B) and throughout the lead wire of stator coil.

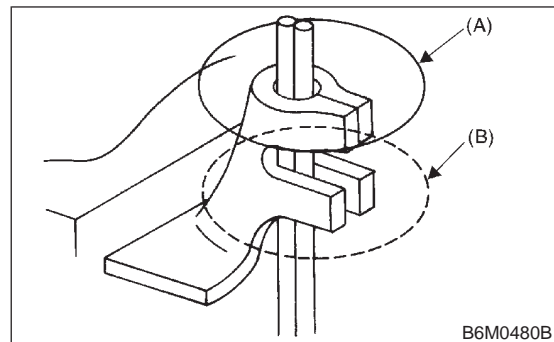

(3) Remove stator coil from diode plate.

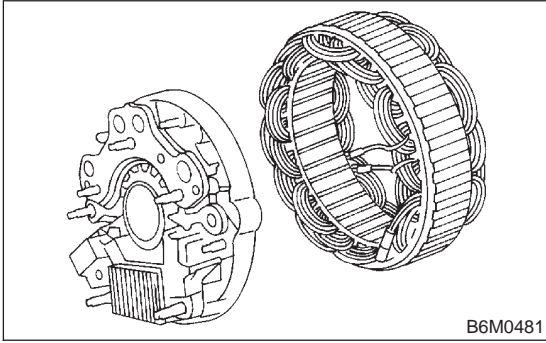

8) Remove bolts which secure IC regulator, diode and brush holder.

**CAUTION:**

Do not apply a shock or load to IC regulator cooling fins.

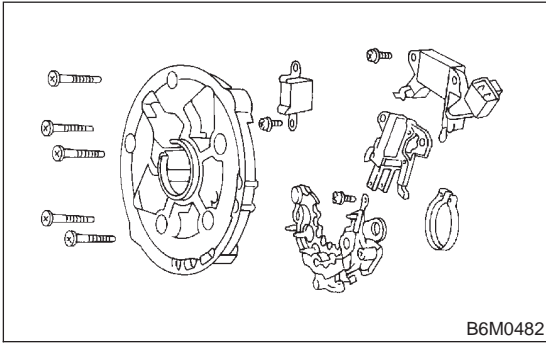

**D: ASSEMBLY** S109008A02

Assemble in the reverse order of disassembly.

**CAUTION:**

● When disassembling generator, replace rear ball bearing.

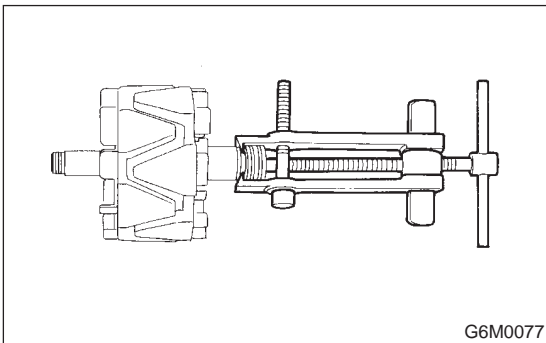

● When soldering starter coil to diode, do not touch lead wire with solder for more than 5 seconds.

● Before installing rear cover, insert pin from outside of rear cover so that holds brush. After installing rear cover, remove pin.

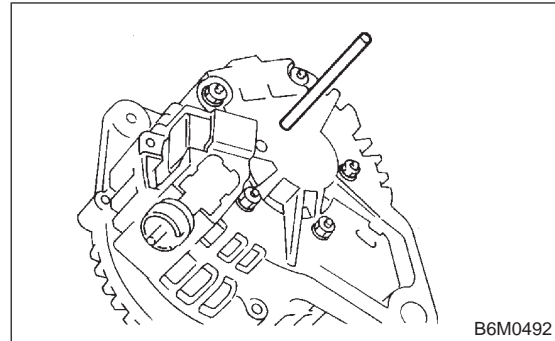

● When installing rear cover, heat portion (A) to 50°C (122°F) with heater drier.

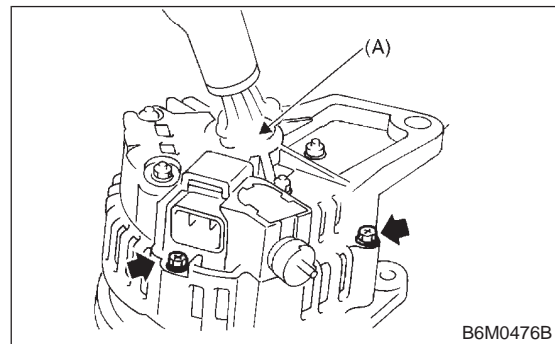

**E: INSPECTION** S109008A10

**1. ROTOR** S109008A1001

1) Slip ring surface  
Inspect slip rings for contamination or any roughness of the sliding surface.  
Clean or polish with #500 to #600 emery paper if defective.

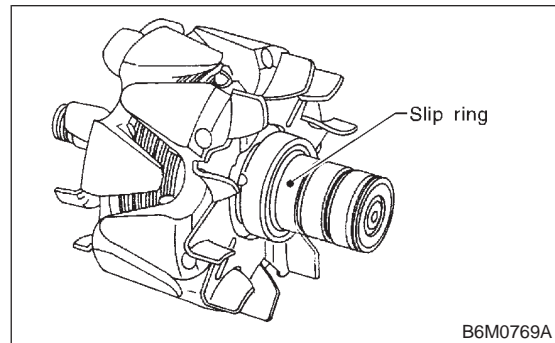

# GENERATOR

## Starting/Charging Systems

### 2) Slip ring outside diameter

Measure slip ring outside diameter. If slip ring is worn, replace rotor.

#### Slip ring outside diameter:

##### Standard

27 mm (1.06 in)

##### Limit

26 mm (1.02 in)

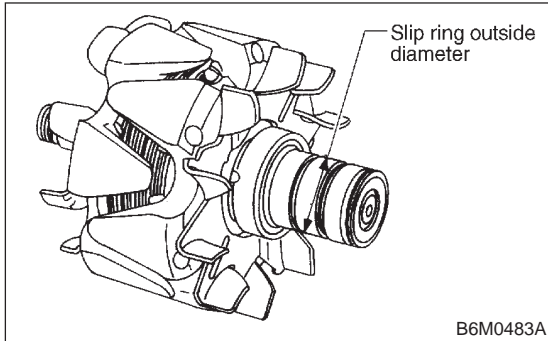

### 3) Continuity test

Check continuity between slip rings. If continuity does not exist, replace rotor.

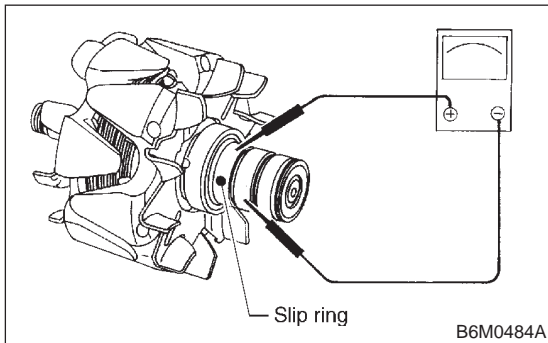

### 4) Insulation test

Check continuity between slip ring and rotor core or shaft. If continuity exists, replace rotor.

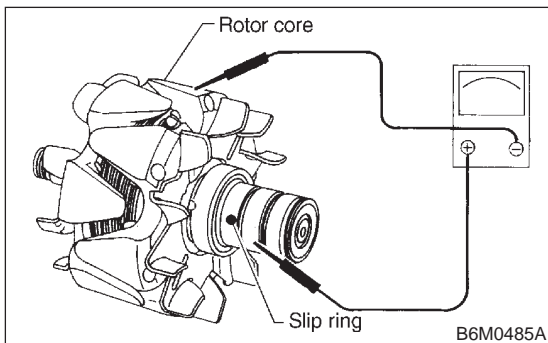

### 5) Ball bearing

Check rear ball bearing. Replace it if it is noisy or if rotor does not turn smoothly.

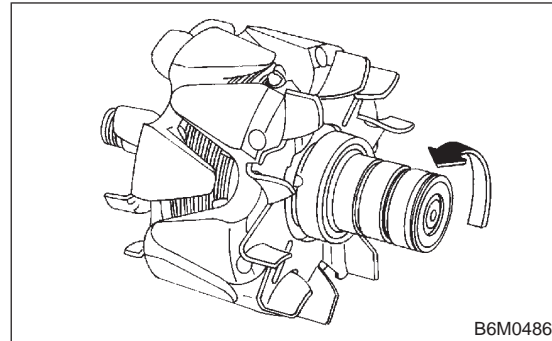

## 2. STATOR S109008A1002

### 1) Continuity test

Inspect stator coil for continuity between its terminals. When there is no continuity between individual terminals, cable is broken. Replace stator coil.

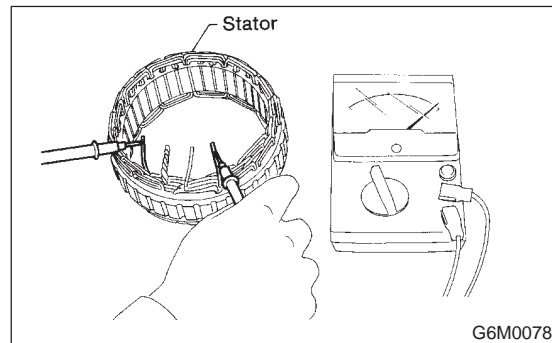

### 2) Insulation test

Inspect stator coil for continuity between stator core and each terminal. If there is continuity, replace stator coil.

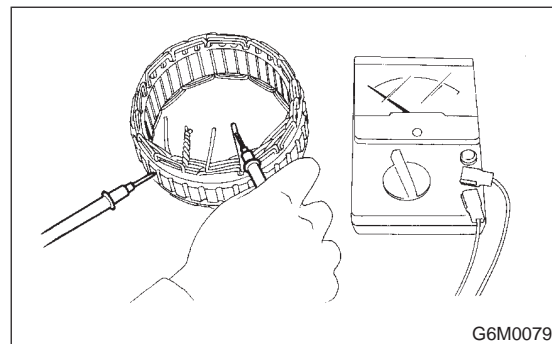

### 3. BRUSH S109008A1003

Measure brush length. If brush is worn, replace brush holder assembly.

**Brush length ( $\ell$ ):**

**Standard**

**20.5 mm (0.807 in)**

**Limit**

**1.5 mm (0.059 in)**

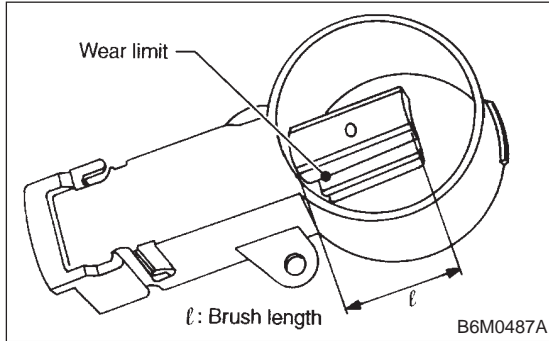

### 4. DIODE ASSEMBLY S109008A1004

**CAUTION:**

**Never use a high tension insulation tester, such as a meggar as it will damage diodes with its high tension.**

The diode consists of eight diodes, four each being located on the positive and negative sides. The diode is necessary to restrict current flow to one direction.

Check all diodes, for continuity. If any diode is faulty, replace diode assembly.

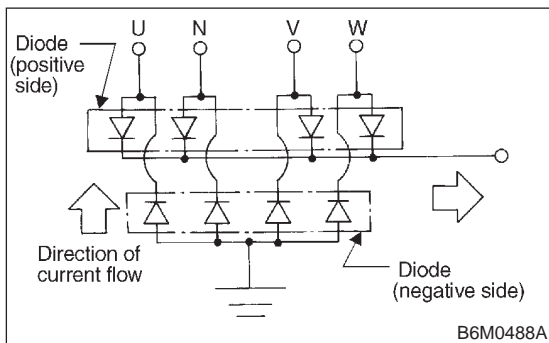

#### 1) Diodes on “+” side

Continuity of proper diodes on “+” side

Terminal N, U, V and W	BAT side	
	(+)	(-)
(+)	—	Continuity must not exist.
(-)	Continuity must exist.	—

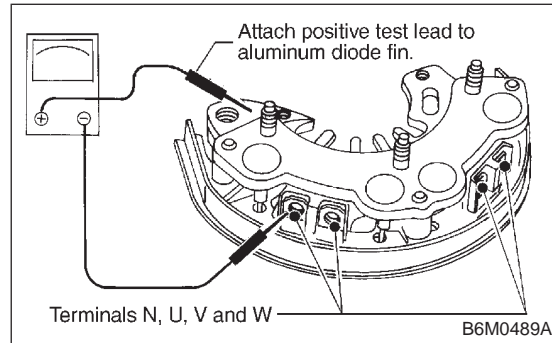

#### 2) Diodes on “-” side

Continuity of proper diodes on “-” side

Terminal N, U, V and W	“E” side	
	(+)	(-)
(+)	—	Continuity must exist.
(-)	Continuity must not exist.	—

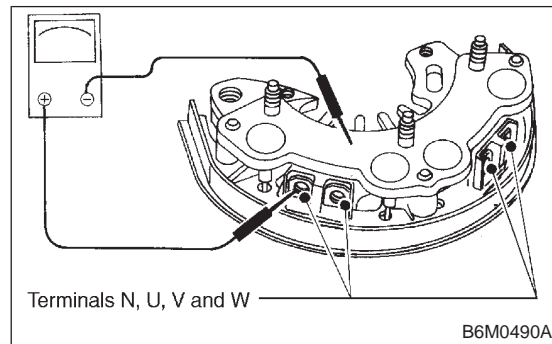

# GENERATOR

## 5. IC REGULATOR S109008A1005

1) Compose a circuit diagram as shown in figure.

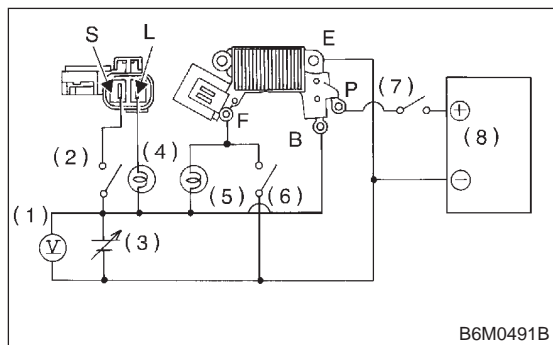

- (1) Voltage meter: 0 to 30 V
- (2) Switch 1
- (3) Variable DC power supply: Variable 0 to 20 V, 1 A or more
- (4) Lamp 2
- (5) Lamp 1
- (6) Switch 3
- (7) Switch 2
- (8) Plus generator: Power supply 5 to 30 V, 1 kHz

2) Check operation as shown in chart below.

No.	Switch operation			Value of voltage meter	Lamp operation		Remarks
	1	2	3		1	2	
1	ON	OFF	OFF	12 V	DIM	ON	Check initial excitation.
2	ON	ON	OFF	12 V	ON or BLINK	OFF	Check total excitation.
3	ON	ON	OFF	16 V	OFF or DIM-BLINK	OFF	When value of voltage meter is between 12 V and 16 V.
4	OFF	ON	OFF	12 V	ON or BLINK	ON	Check connection for S and B terminals.
5	OFF	ON	ON	18 V	ON	ON	Check for over loading of voltage.