

20. Disc Brake Pads and Discs

SA07695

A: INSPECTION SA07695A10

1. DISC BRAKE PAD AND DISC SA07695A1001

- 1) Jack up vehicle and support with rigid racks. Then remove wheels.
- 2) Visually check pad thickness through inspection hole of disc brake assembly. Replace pad if necessary.

NOTE:

When replacing a pad, always replace the pads for both the left and right wheels at the same time. Also replace pad clips if they are twisted or worn.

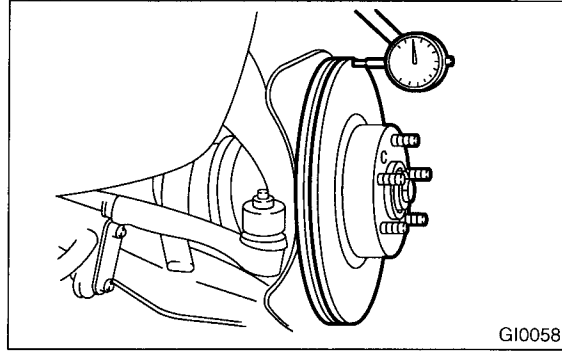
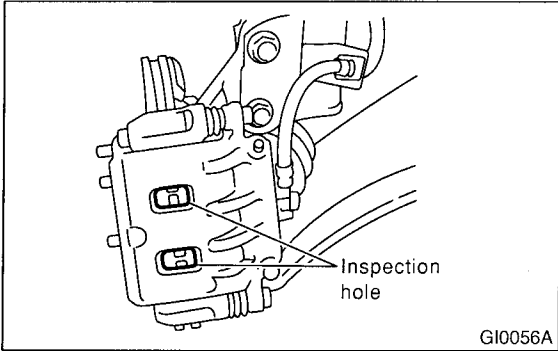

Pad thickness including back metal mm (in)		
	Front	Rear
Standard	17 (0.67)	14 (0.55)
Service limit	7.5 (0.295)	6.5 (0.256)
Service limit (exclusive back metal)	1.5 (0.059)	1.5 (0.059)

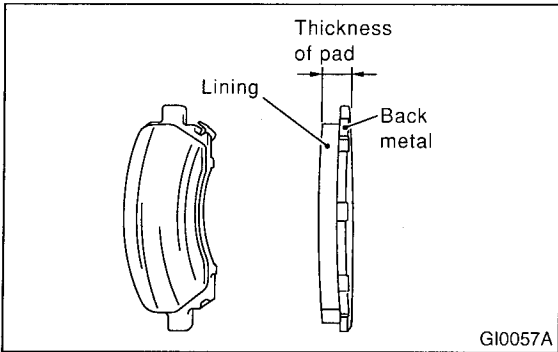

- 3) Check the disc rotor, and correct or replace if it is damaged or worn.

Brake disc thickness mm (in)		
	Front	Rear
Standard	24 (0.94)	10 (0.39)
Wear limit	22 (0.87)	8.5 (0.335)

- 4) Measure the disc rotor runout at a point less than 5 mm (0.20 in) from the outer periphery of the rotor.

Disc rotor runout limit:

Front: 0.075 mm (0.0030 in)

Rear: 0.075 mm (0.0030 in)