

2. General Description S001001

A: CAUTION S001001A03

- 1) Never connect the battery in reverse polarity.
 - The Auto A/C control module will be destroyed instantly.
- 2) Do not disconnect the battery terminals while the engine is running.
 - A large counter electro motive force will be generated in the alternator, and this voltage may damage electronic parts such as A/C control module.
- 3) Before disconnecting the connectors of each sensor and the A/C control module, be sure to turn off the ignition switch.
 - Otherwise, the Auto A/C control module may be damaged.
- 4) Every Auto A/C-related part is a precision part. Do not drop them.
- 5) Airbag system wiring harness is routed near the A/C control panel (A/C control module) and junction box.

CAUTION:

- All Airbag system wiring harness and connectors are colored yellow. Do not use electrical test equipment on these circuits.
- Be careful not to damage Airbag system wiring harness when servicing the A/C control panel (A/C control module) and junction box.

B: INSPECTION S001001A10

Before performing diagnosis, check the following items which might affect engine problems.

1. BATTERY S001001A1001

- 1) Measure battery voltage and specific gravity of electrolyte.

Standard voltage: 12 V

Specific gravity: Above 1.260

- 2) Check the condition of the fuses for A/C, heater and other fuses.
- 3) Check the condition of the harnesses and harness connectors connection.

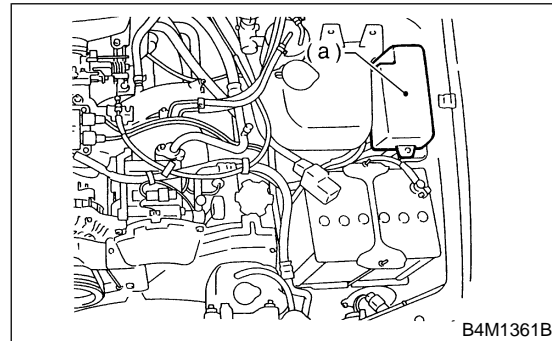

(a) Main fuse box

2. ASPIRATOR HOSE S001001A1002

- 1) Make sure that the aspirator hose is securely connected to the heater unit by inserting a hand from the driver's compartment and secure as necessary.
- 2) Turn ignition switch to ON.
- 3) Push "DEF" switch and then blower fan switch to turn the blower fan to maximum speed.

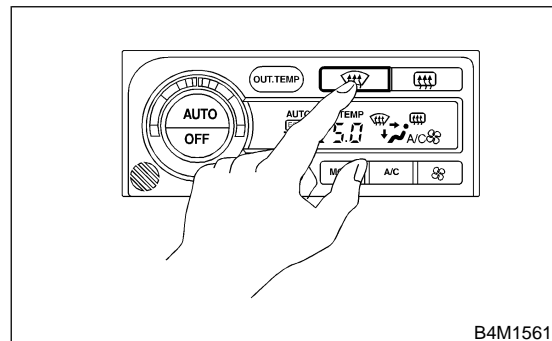

GENERAL DESCRIPTION

HVAC System (Auto A/C) (DIAGNOSTICS)

4) Firmly hold a thin thread (b) in front of the in-vehicle sensor suction port (a) for the auto A/C control unit and check that the thread moves towards the port indicating that air is being sucked into the port.

NOTE:

- Ensure the thread does not get sucked into the port.
- Hold the thread approximately 5 mm (0.02 in) away from the port when the suction force is not very strong.

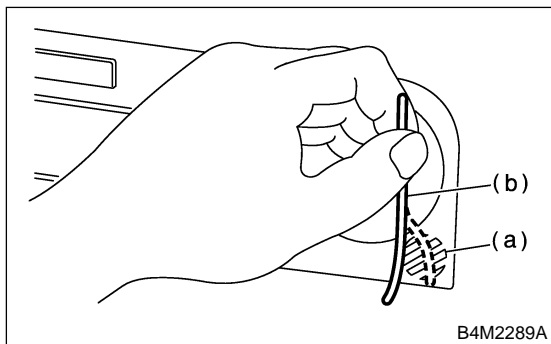

5) If the thread does not move at all, remove the auto A/C control unit <Ref. to AC-30 AUTO A/C, REMOVAL, Control Unit.> and check for improper connection of the aspirator hose (a) and auto A/C control unit and secure as necessary.

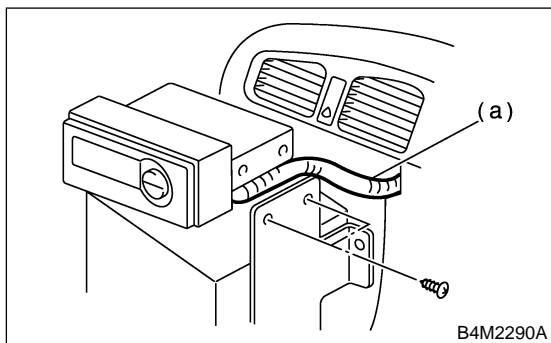

3. REFRIGERANT LINE S001001A1003

Check contact for refrigerant line (A).

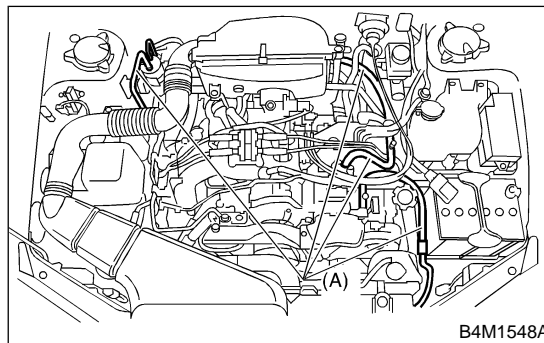

4. CONTROL LINKAGE S001001A1004

- 1) Check state of mode door control rod and linkage.
- 2) Check state of air mix door control rod and linkage.
- 3) Check state of intake door control rod and linkage.

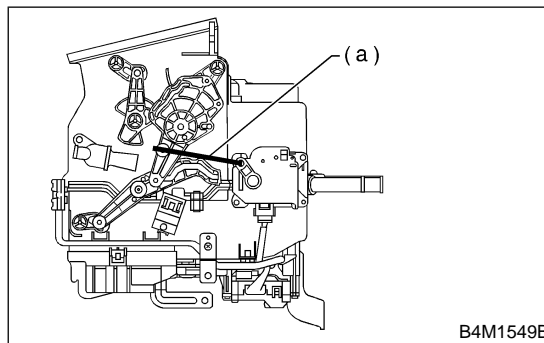

(a) Control rod

GENERAL DESCRIPTION

HVAC System (Auto A/C) (DIAGNOSTICS)

5. CONTROL SWITCHES S001001A1006

Start and warm up engine completely.

1) Inspection using switches.

No.	Point to check	Switch operation	Judgement standard
1	OFF switch	OFF switch "ON"	"SET" temperature display go out. <ul style="list-style-type: none"> ● Air flow → OFF ● Outlet → HEAT ● Inlet → FRESH ● Compressor → OFF
2	AUTO switch	A. AUTO switch "ON" B. Temp. control switch 18°C (65°F) (Max. Cold)	a. AUTO switch display illuminates. b. <ul style="list-style-type: none"> ● Outlet air → Cool ● Air flow → HI (AUTO) ● Outlet → VENT ● Inlet → AUTO ● Compressor → AUTO
		C. TEMP control switch is gradually set from 18°C (65°F) to 32°C (85°F).	c. Air and air outlet mode change as follows: <ul style="list-style-type: none"> ● Outlet air: cool → hot ● Air flow: AUTO ● Outlet: VENT → BI-LEVEL → HEAT ● Inlet: AUTO
		D. Temp. control switch 32°C (85°F) (Max. Hot)	d. Outlet air → Hot <ul style="list-style-type: none"> ● Air flow → HI (AUTO) ● Outlet → HEAT ● Inlet → FRESH (AUTO) ● Compressor → AUTO
3	DEF switch	A. DEF switch "ON" B. Temp. control switch 18 — 32°C (65 — 85°F)	a. DEF switch display illuminates. b. <ul style="list-style-type: none"> ● Outlet air temperature (AUTO control) ● Air flow (AUTO control) ● Outlet → DEF ● Inlet → FRESH ● Compressor → ON
4	FRESH/RECIRC switch	FRESH/RECIRC switch "ON"	Changes from RECIRC → FRESH, or FRESH → RECIRC.
5	MODE switch	MODE switch "ON"	Outlet changes from VENT → BI-LEVEL → HEAT → DEF/HEAT each time MODE switch is pushed.
6	FAN switch	FAN switch "ON"	Fan speed changes from LO → M1 → M2 → HI each time FAN switch is pushed.
7	OUT-TEMP switch	OUT-TEMP switch "ON"	Ambient temperature flashes on "set" temperature display, and "set" temperature appears.

2) Compressor operation inspection

No.	Point to check	Switch operation	Judgement standard	Remarks
1	Compressor	A. AUTO switch "ON" B. A/C switch "ON" C. DEF switch "ON"	a. Compressor ON b. Compressor ON c. Compressor ON	Compressor turns OFF several seconds after AUTO switch is turned ON.

3) Illumination control inspection

No.	Point to check	Switch operation	Judgement standard	Remarks
1	Illumination switch	Lighting switch "ON"	Illumination light illuminates and both switch light and "set" temperature display dim. <ul style="list-style-type: none"> ● Switch lights: OFF → Green light illuminates. ON → Green light illuminates. 	Green lights remain on although OFF and OUT-TEMP switches are ON.