

REFRIGERANT CHARGING PROCEDURE

HVAC System (Heater, Ventilator and A/C)

4. Refrigerant Charging Procedure

S701292

A: OPERATION

S701292A16

CAUTION:

- During operation, be sure to wear safety goggles and protective gloves.
- Before charging the refrigerant, evacuate the system to remove small amounts of moisture remaining in the system.

The moisture in the system can be completely evacuated only under the minimum vacuum level. The minimum vacuum level affects the temperature in the system.

- The list below shows the vacuum values necessary to boil water in various temperature. In addition, the vacuum levels indicated on the gauge are approx. 3.3 kPa (25 mmHg, 0.98 inHg) lower than those measured at 304.8 m (1,000 ft) above sea level.

Vacuum level required to boil water (at sea level)	
Temperature	Vacuum
1.7°C (35°F)	100.9 kPa (757 mmHg, 29.8 inHg)
7.2°C (45°F)	100.5 kPa (754 mmHg, 29.7 inHg)
12.8°C (55°F)	99.8 kPa (749 mmHg, 29.5 inHg)
18.3°C (65°F)	99.2 kPa (744 mmHg, 29.3 inHg)
23.9°C (75°F)	98.5 kPa (739 mmHg, 29.1 inHg)
29.4°C (85°F)	97.2 kPa (729 mmHg, 28.7 inHg)
35°C (95°F)	95.8 kPa (719 mmHg, 28.3 inHg)

- 1) Close the valves on low-/high-pressure sides of the manifold gauge.

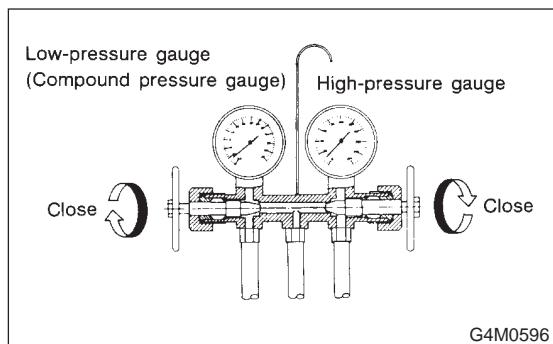

- 2) Install the low-/high-pressure hoses to the corresponding service ports on the vehicle respectively.

- 3) Connect the center hose of the manifold gauge set with the vacuum pump.

- 4) Carefully open the valves on the low-/high-pressure sides to activate the vacuum pump.

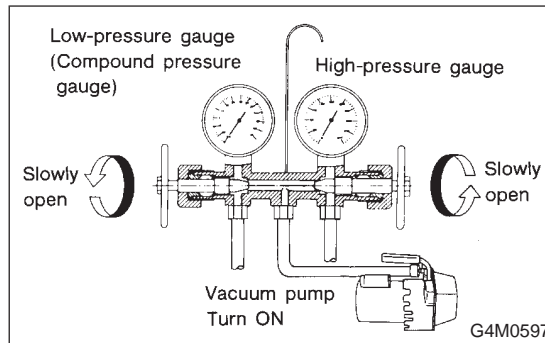

- 5) After the low-pressure gauge reaches 100.0 kPa (750 mmHg, 29.5 inHg) or higher, evacuate the system for approx. 15 minutes.

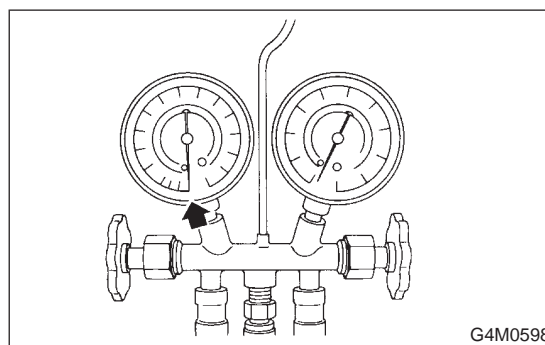

- 6) After 15 minutes of evacuation, if the reading shows 100.0 kPa (750 mmHg, 29.5 inHg) or higher, close the valves on the both sides to stop the vacuum pump.

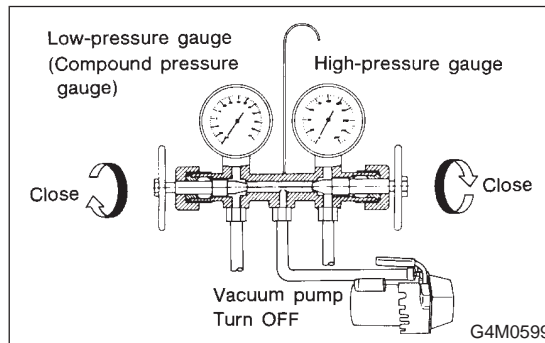

- 7) Note the low-pressure gauge reading.

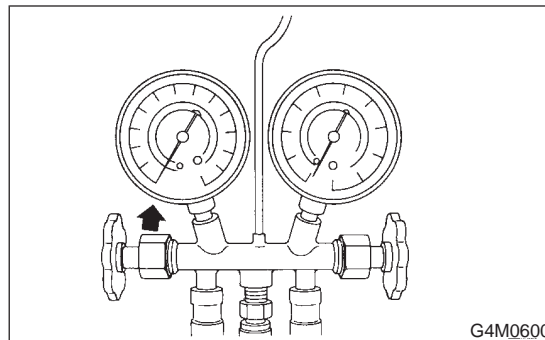

REFRIGERANT CHARGING PROCEDURE

HVAC System (Heater, Ventilator and A/C)

8) Leave it at least 5 minutes, and then check the low-pressure gauge reading for any changes.

When a gauge indicator shows near to zero point, this is a sign of leakage. Check pipe connector points, repair them, make sure there is no leakage by air bleeding.

9) Following the can tap operation manual instructions, install it to the refrigerant can.

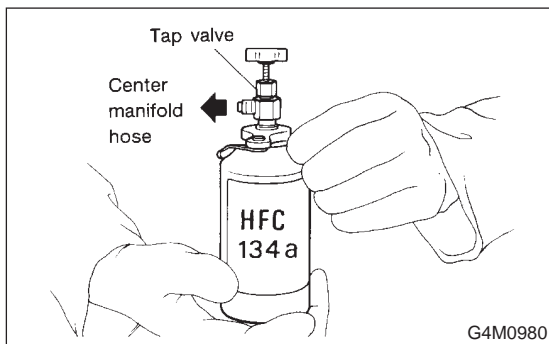

10) Disconnect the center manifold hose from the vacuum pump, and connect the hose to the tap valve.

11) When a 13.6 kg (30 lb) refrigerant container is used, measure the refrigerant amount in use using a weighting scale.

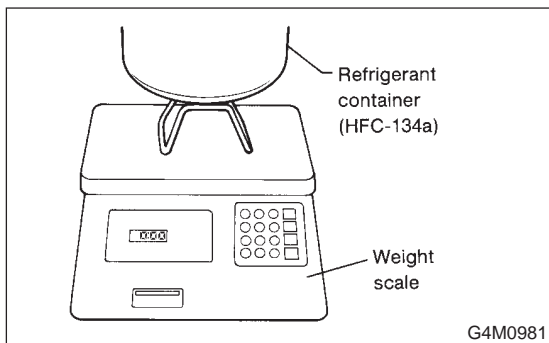

12) Confirm that all the 3 hoses are tightly connected to the manifold gauge set.

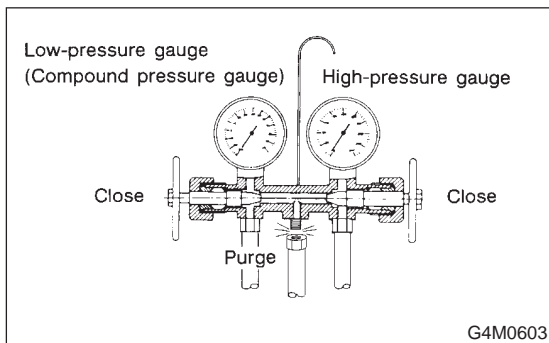

13) Open the valve on the HFC-134a source.

14) Loosen the center hose connection on the manifold gauge set (if applicable, press a purge valve on the manifold gauge set) only for a couple of seconds to allow the air in the center hose to escape by the refrigerant.

15) Carefully open the high-pressure valve with the engine OFF.

CAUTION:
Do not open the low-pressure valve.

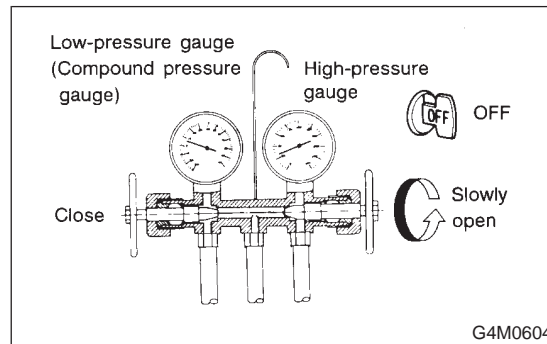

CAUTION:
Never run the engine during charging from the high-pressure side.

16) Close the high-pressure valve when the low-pressure gauge reaches 98 kPa (1 kg/cm², 14 psi). Using a leak tester, check the system for leaks.

If any leakage is found after the refrigerant recovery is completed, repair the applicable area.

17) After confirming that there are no leaks with the leak test, charge the required amount of refrigerant.

CAUTION:
Never run the engine during charging from the high-pressure side.

18) Close the high-pressure valve when;

- the readings of low- and high-pressure gauges become almost equal, after the charging speed is reduced,

- the HFC-134a source becomes empty, or
- the system is filled with the gas.

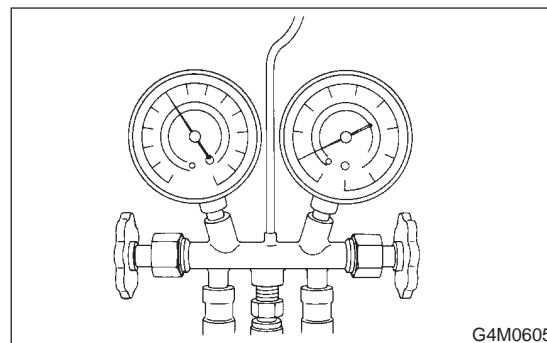

REFRIGERANT CHARGING PROCEDURE

HVAC System (Heater, Ventilator and A/C)

19) If the HFC-134a source is empty, close the high-pressure valve, close the valve on the can tap, and replace the HFC-134a source with a new one to restart the operation.

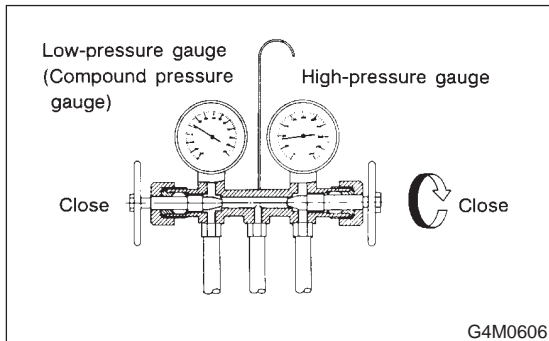

20) Confirm that both the low- and high-pressure valves can be closed. Start the engine with the A/C switch OFF.

21) Quickly repeat ON-OFF cycles a few times to prevent initial compressor damage.

22) Set up the vehicle to the following status:

- A/C switch ON
- Engine running at 1,500 rpm
- Blower speed setting to "HI"
- Temperature setting to "MAX COOL"
- Air inlet setting to "RECIRC"
- Windows open

23) While reading the low-pressure gauge, carefully open the low-pressure valve with the refrigerant source connected and the service hose purged.

CAUTION:

Never open the high-pressure valve with the engine running.

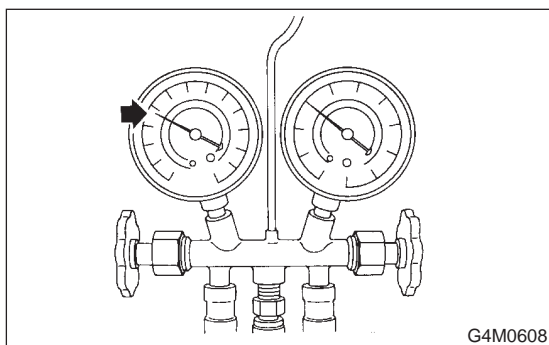

24) Adjust the refrigerant flow to maintain the pressure on the low-pressure side at 276 kPa (2.81 kg/cm², 40 psi) max.

25) After the system is fully charged, close the low-pressure valve.

26) Close the valve on the refrigerant source.

Refrigerant amount			
Refrigerant		Minimum	Maximum
HFC-134a	LHD	0.6 kg (1.3 lb)	0.7 kg (1.5 lb)
	RHD	0.4 kg (0.9 lb)	0.5 kg (1.1 lb)

27) Disconnect the hose from the service port, and install the service port cap.