

REFRIGERANT LEAK CHECK

HVAC System (Heater, Ventilator and A/C)

5. Refrigerant Leak Check S701293

A: INSPECTION S701293A10

1) Operate the A/C system for approx. 10 minutes, and confirm that the high-side pressure shows at least 690 kPa (7.03 kg/cm², 100 psi). Then stop the engine to start the leak test.

2) Starting from the connection between the high-pressure tube and evaporator, check the system for leaks along the high-pressure side through the compressor. The following items must be checked thoroughly.

- Connection between the tube and tube fitting

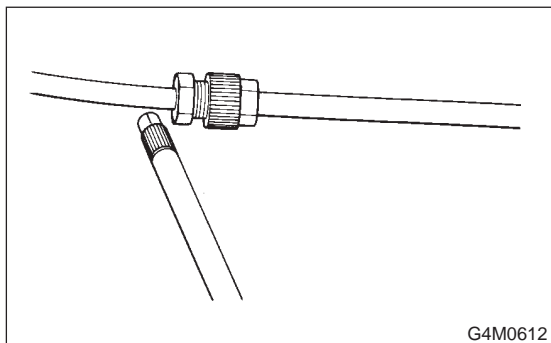

- Connection between 2 parts

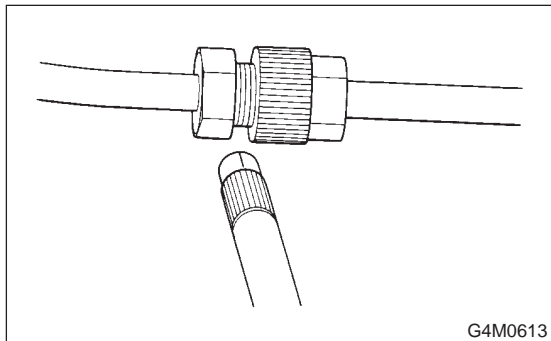

- Connection between the tube and nut

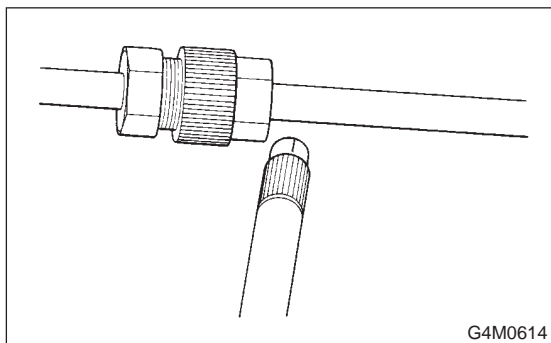

3) Check the joint and seam between the pressure switch (dual switch) and receiver dryer.

4) Check the connections between the condenser and tubes, and welded joints on the condenser. The leak tester may detect the oil on the condenser fins as a leak.

5) Check the joint between the compressor and hoses.

6) Check the machined area of compressor and other joints on the compressor.

7) Check the thermal limiter (if equipped) on the compressor housing.

8) Check the compressor shaft seal at the area near the center of compressor clutch pulley.

Some shaft seals show a slight amount of leakage about 28 g (1.0 oz) per year. This is not a problem.

9) Starting from the connection between the low-pressure tube and evaporator, check the system for leakage along the high-pressure side through the compressor. The following items must be checked thoroughly.

- Connection between the tube and tube fitting
- Connection between 2 parts
- Connection between the tube and nut

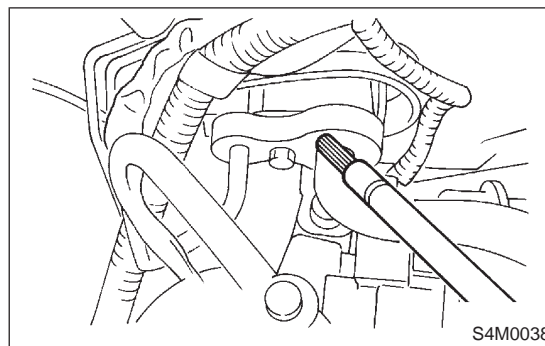

10) Visually check the rubber area of the flexible hose for cracks.

Check the entire length of the flexible hose, especially the connection with the metal hose end.

CAUTION:

Carefully check the external surface of hoses and tubes at approx. 25 mm (0.98 in) per second.

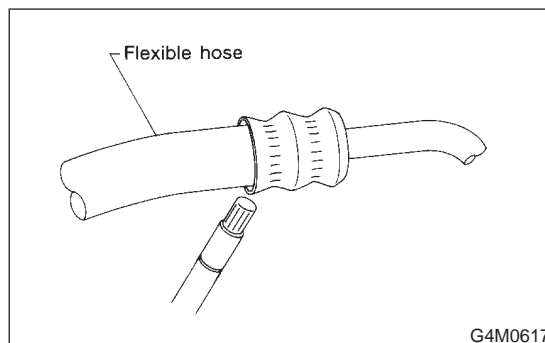

11) Disconnect the drain hose from the evaporator case, and check the hose end for at least 10 seconds.

After the test is finished, reconnect the drain hose.

REFRIGERANT LEAK CHECK

HVAC System (Heater, Ventilator and A/C)

12) Turn the ignition key to ON position, and run the blower at high speed for 1 minute. Stop the blower to check the ventilation grill on the instrument panel. While moving the tester closer to the grill, run the blower for 1 or 2 seconds, then stop it. Check the grill at that point for at least 10 seconds.

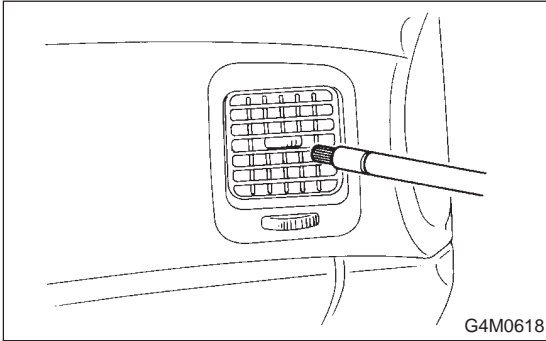

13) Check the valve in the service port.
14) Visually check the rubber seal in the service port cap.

