

## 12. Compressor S701281

### A: INSPECTION S701281A10

#### 1. MAGNETIC CLUTCH CLEARANCE

S701281A1001

1) Check the clearance of the entire circumference around the drive plate and pulley.

**Standard:**

**$0.45 \pm 0.15 \text{ mm (} 0.0177 \pm 0.0059 \text{ in)}$**

#### 2. MAGNETIC CLUTCH OPERATION

S701281A1002

- 1) Disconnect the compressor connector.
- 2) Connect the No. 3 terminal of the compressor connector from the battery to the positive (+) lead. Ground the negative (-) lead to the body.

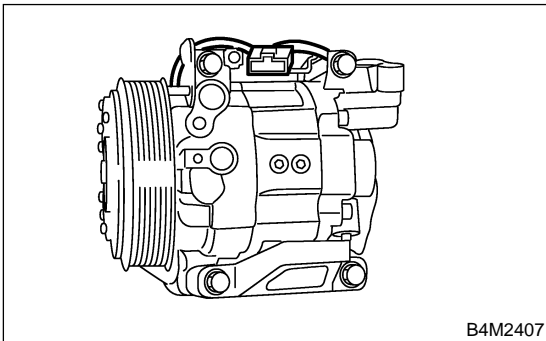

3) Make sure the magnet clutch engages. If NG, replace the compressor.

### B: REMOVAL S701281A18

- 1) Perform oil return operation. <Ref. to AC-24 OPERATION, Compressor Oil.>
- 2) Turn A/C switch OFF and stop the engine.
- 3) Using refrigerant recovery system, discharge refrigerant. <Ref. to AC-18 OPERATION, Refrigerant Recovery Procedure.>
- 4) Disconnect ground cable from battery.
- 5) Remove duct (A).

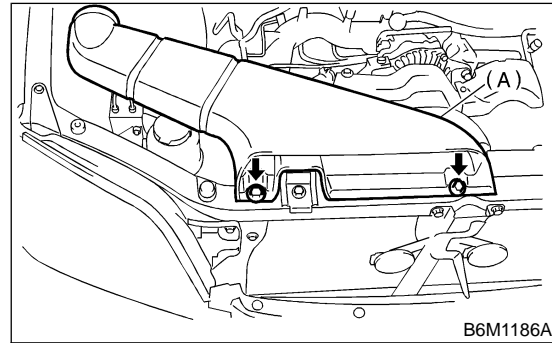

6) Disconnect low-pressure hose (A) and high-pressure hose (B).

**CAUTION:**

**Be careful not to lose O-rings on hose. Immediately seal hose with a plug or vinyl tape to prevent the entry of contamination.**

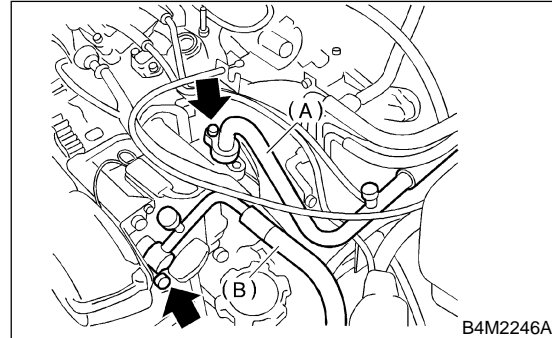

- 7) Remove V-belt. <Ref. to ME(H4)-43 REMOVAL, V-belt.>
- 8) Remove generator. <Ref. to SC(H4)-15 REMOVAL, Generator.>
- 9) Disconnect compressor harness from body harness.

# COMPRESSOR

HVAC System (Heater, Ventilator and A/C)

10) Remove bolts from compressor bracket.

## 4 CYLINDERS:

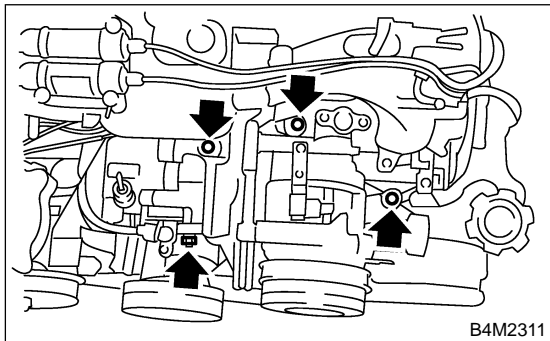

## C: INSTALLATION S7012B1A11

- 1) Install in the reverse order of removal.
- 2) Replace O-rings on low-/high-pressure hoses with new ones, then apply compressor oil.
- 3) When replacing compressor, adjust amount of compressor oil. <Ref. to Compressor Oil.>
- 4) Charge refrigerant. <Ref. to AC-19 OPERATION, Refrigerant Charging Procedure.>

## 6 CYLINDERS:

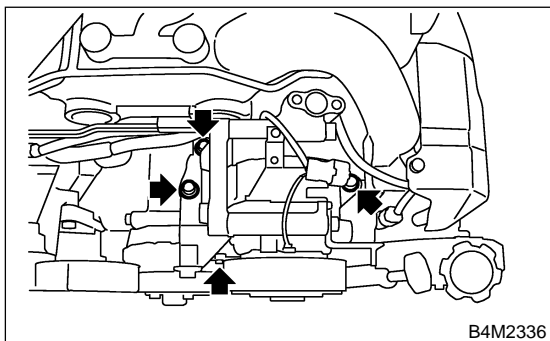

11) Loosen bolts to remove compressor from bracket.

