

## 13. Condenser S701282

### A: REMOVAL S701282A18

- 1) Using refrigerant recovery system, discharge refrigerant. <Ref. to AC-18 OPERATION, Refrigerant Recovery Procedure.>
- 2) Disconnect ground cable from battery.
- 3) Remove duct (A).

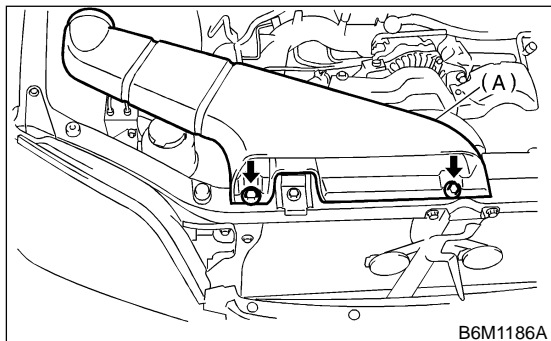

- 4) Disconnect high-pressure hose (A) and low-pressure hose (B) from condenser.

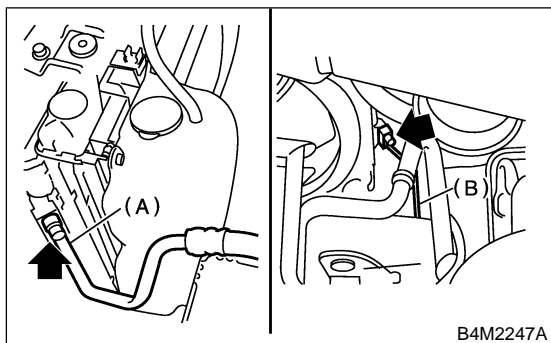

- 5) Remove radiator bracket (A).

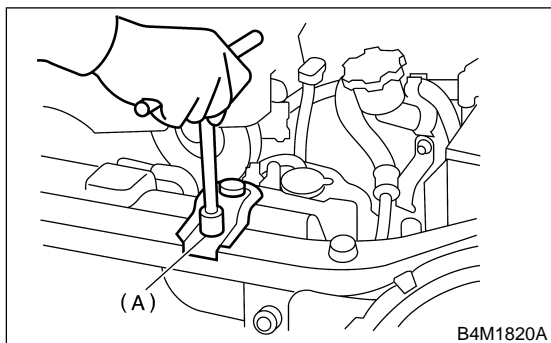

- 6) Remove 2 bolts. While lifting condenser, pull it out through the space between the radiator and the radiator panel.

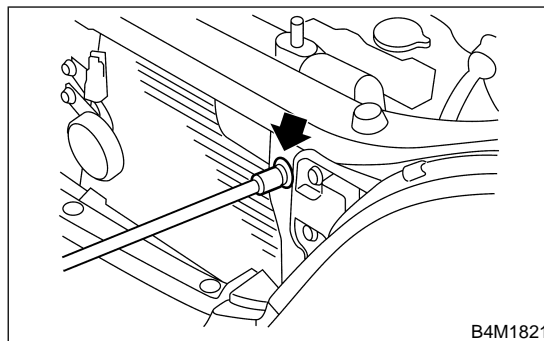

### CAUTION:

Be careful not to damage condenser fins. If a damaged fin is found, repair it using a thin screwdriver.

If condenser is replaced, add appropriate amount of compressor oil to the compressor. <Ref. to AC-24 REPLACEMENT, Compressor Oil.>

### B: INSTALLATION S701282A11

- 1) Install in the reverse order of removal.

### CAUTION:

Replace O-rings on hoses or pipes with new ones, and then apply compressor oil. Confirm that lower guide of condenser panel has been fitted into holes on radiator panel.

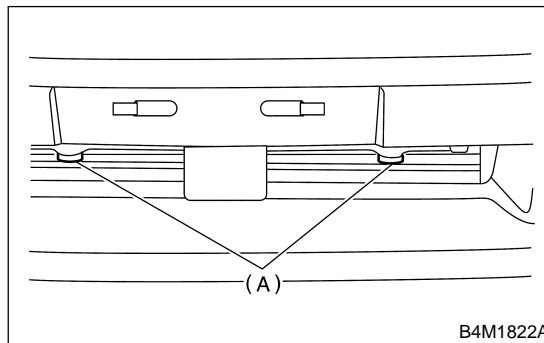

- 2) Charge refrigerant. <Ref. to AC-19 OPERATION, Refrigerant Charging Procedure.>

### C: INSPECTION S701282A10

- 1) Confirm that no dust or insects are found on the condenser fins. Air-blow or flush fins with water as needed.
- 2) Confirm that no oil leaks from condenser. If a failure is found, replace condenser with a new one.