

15. Intake Unit S701632

A: REMOVAL S701632A18

- 1) Using refrigerant recovery system, discharge refrigerant. <Ref. to AC-18 OPERATION, Refrigerant Recovery Procedure.>
- 2) Disconnect ground cable from battery.
- 3) Remove bolts securing expansion valve and pipe in engine compartment.

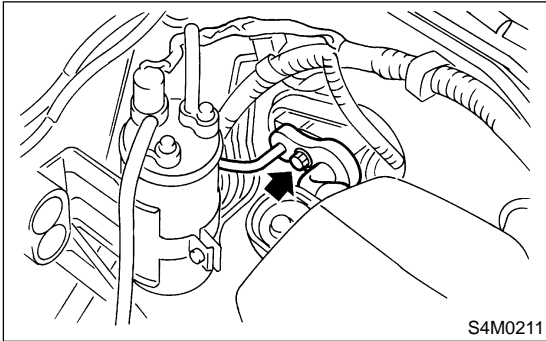

- 4) Remove instrument panel. <Ref. to EI-37 REMOVAL, Instrument Panel.>
- 5) Remove keyless unit and CRU unit.

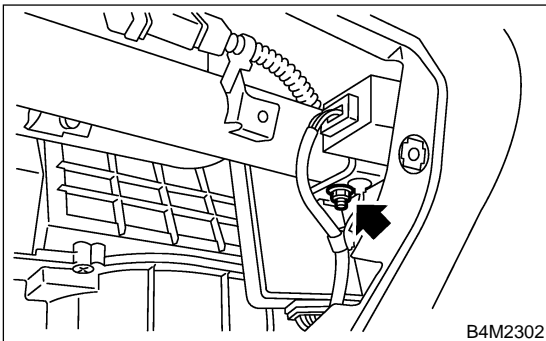

- 6) Disconnect sunroof connector.
- 7) Disconnect servo motor connector.

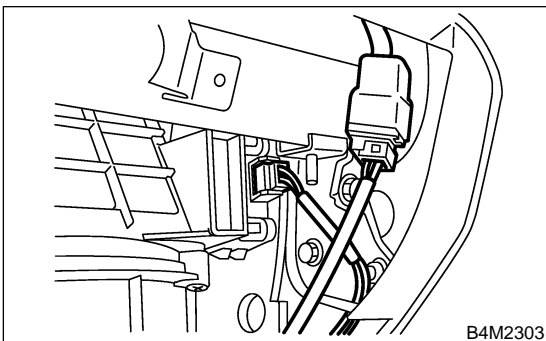

- 8) Disconnect heater blower power transistor connector.
- 9) Disconnect heater blower motor connector.

- 10) Disconnect in-vehicle temperature sensor connector.

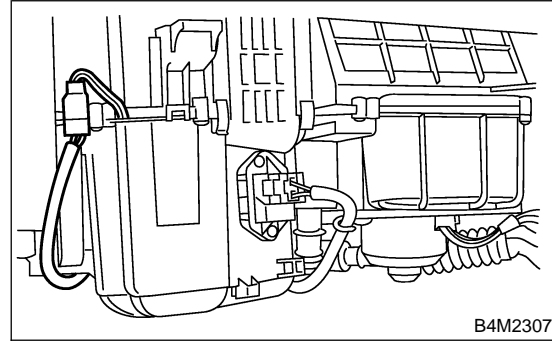

- 11) Remove bolts and nuts on the unit.

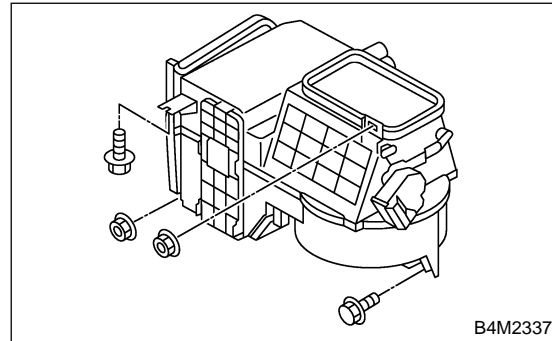

- 12) Disconnect drain hose.
- 13) Remove the unit.

B: INSTALLATION S701632A11

- 1) Install in the reverse order of removal.

CAUTION:
Replace O-rings with new ones, and apply compressor oil.

- 2) Charge refrigerant. <Ref. to AC-19 OPERATION, Refrigerant Charging Procedure.>

INTAKE UNIT

HVAC System (Heater, Ventilator and A/C)

C: DISASSEMBLY S701632A06

- 1) Remove resistor (A) and thermistor (B) from intake unit.
- 2) Remove screws and clips to separate intake unit.

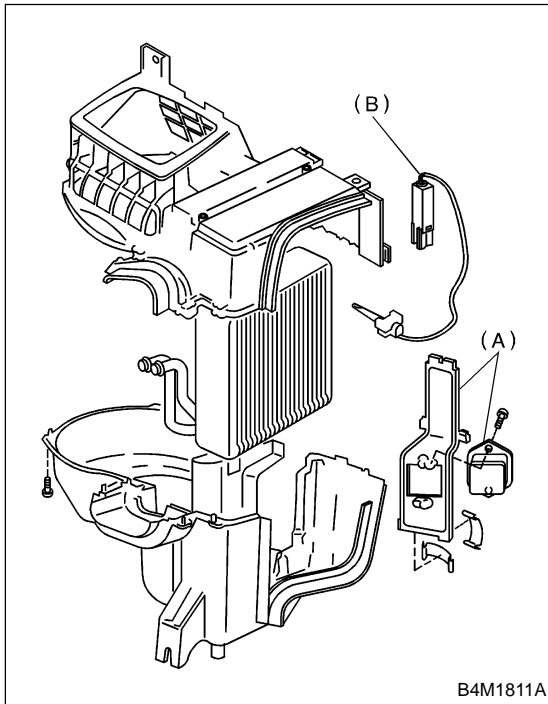

- 3) Remove expansion valve (A) from evaporator.

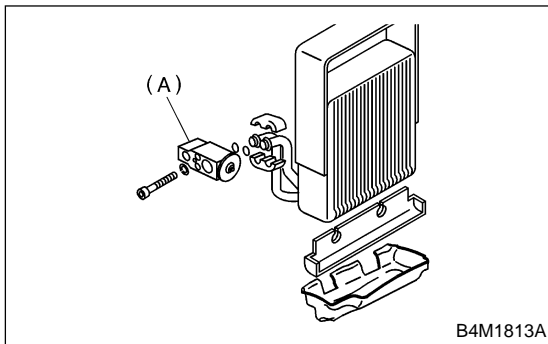

CAUTION:

If evaporator is replaced, add appropriate amount of compressor oil to evaporator. <Ref. to AC-24 REPLACEMENT, Compressor Oil.>

D: ASSEMBLY S701632A02

Assemble in the reverse order of disassembly.

CAUTION:

Replace O-rings with new ones, and then apply compressor oil.