

2. Construction

A: GENERAL

- The airbag system consists of an airbag control module, left and right front sub sensors, an electric sensor and safety sensor built into the control module, driver's and passenger's airbag modules each containing an inflator and airbag, and side airbag sensors and modules each containing an inflator and airbag (Side airbag equipped model).

- **FRONT AIRBAG SYSTEM:**

A frontal impact exceeding the set level causes the safety sensor, electric sensor and one or both front sub sensors to input impact signals to the CPU. The CPU determines whether the airbags should be inflated or not based on these signals.

- **SIDE AIRBAG SYSTEM:**

Input of a side impact signal showing shock energy greater than the set level causes the airbag on the corresponding side to inflate.

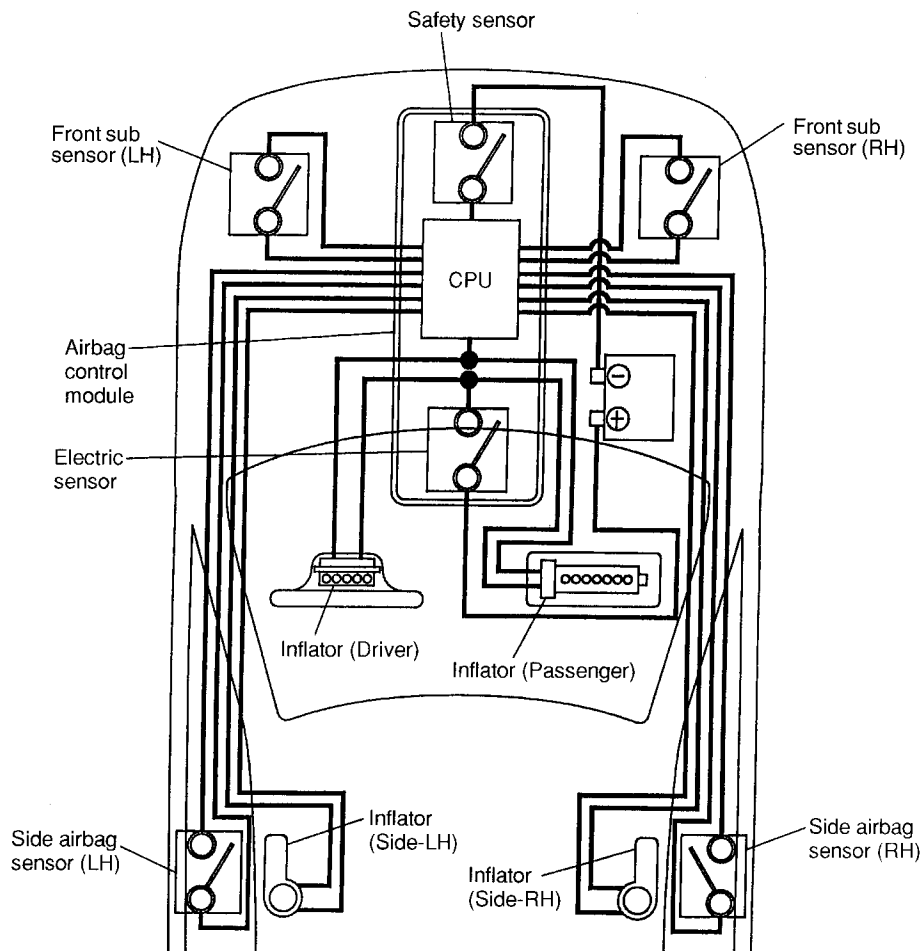

B5H0552A

B: AIRBAG CONTROL MODULE

The airbag control module is installed in front of the front floor tunnel. It detects the vehicle's deceleration by receiving electrical signals from its inside safety and electric sensors as well as the front sub sensors and judges whether to inflate the airbags. This control module has a built-in self-diagnosis function. If a fault occurs inside the system, it lights up the airbag warning light in the combination meter. The fault data is stored in the module. A back-up power supply is provided for possible damage to the battery during an accident, and a boosting circuit is built into the module in case of a battery voltage drop.

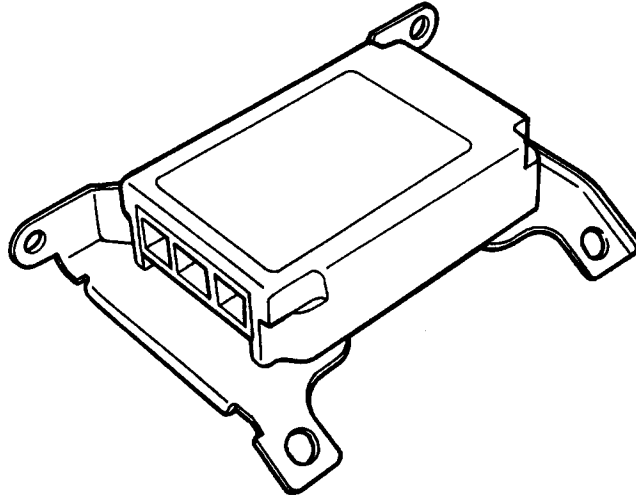

S5H0010

C: FRONT SUB SENSOR

One front sub sensor is installed on each side, in front of the front wheel apron wall. The front sub sensor is a pendulum type sensor. If the sensor receives a frontal impact exceeding a certain limit, the mass in the sensor rotates forward to turn the switch ON.

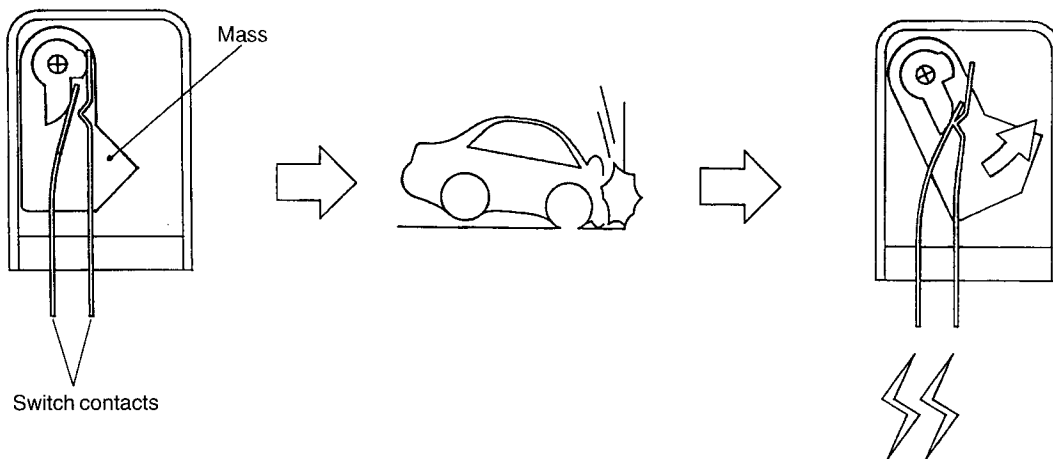

B5H0507B

D: AIRBAG SENSOR

The safety sensor and electric sensor are incorporated into the airbag control module and the side airbag sensors.

The safety sensor is also a pendulum type sensor. If the sensor receives a frontal or side impact exceeding a certain limit, the mass in the sensor moves in the direction opposite to the impact direction to turn the switch ON.

The electric sensor consists of a semiconductor type sensor which senses the deceleration caused by collision in terms of change in the electrical resistance of the impact sensing circuit.

SAFETY SENSOR

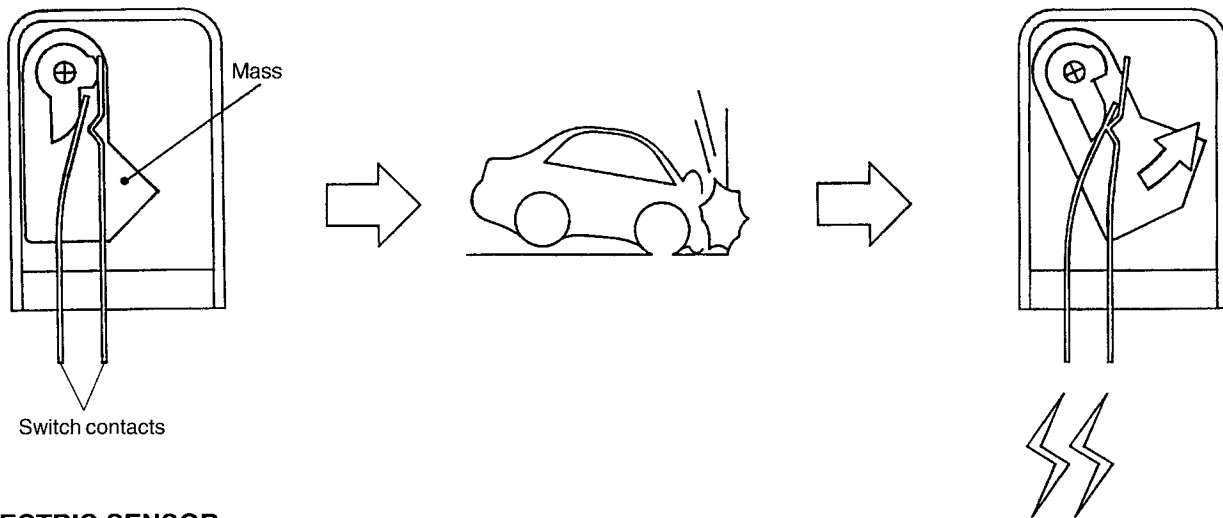

ELECTRIC SENSOR

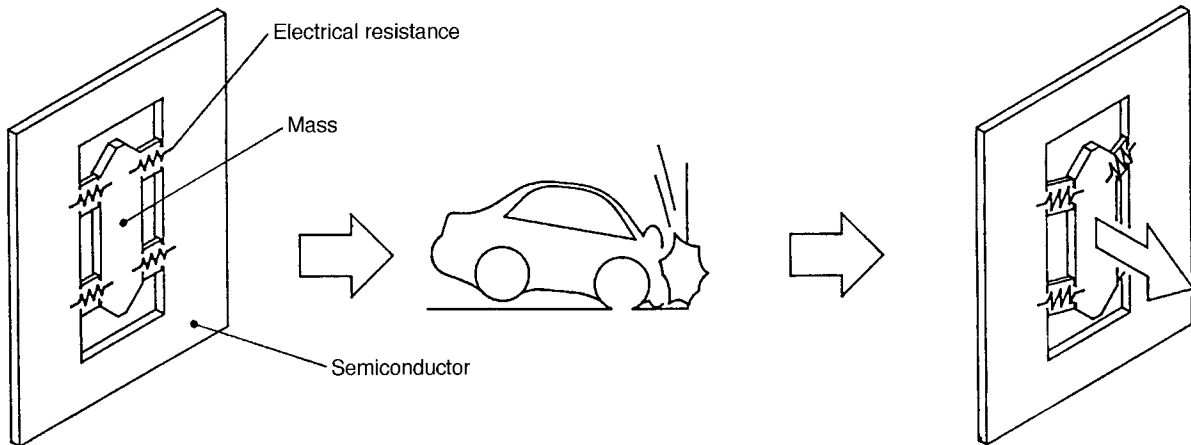

H5H0685B

E: AIRBAG MODULE

1. FRONT AIRBAG

The driver's airbag module is located at the center of the steering wheel and the passenger's airbag module is located at upper portion of instrument panel. Each module contains an airbag and an inflator. If a collision occurs, the inflator produces a large volume of gas to inflate the airbag in a very short time. Contained in the passenger's airbag module is a dual-stage inflator which can inflate the airbag in different timings depending on the severity of impact.

Driver's module

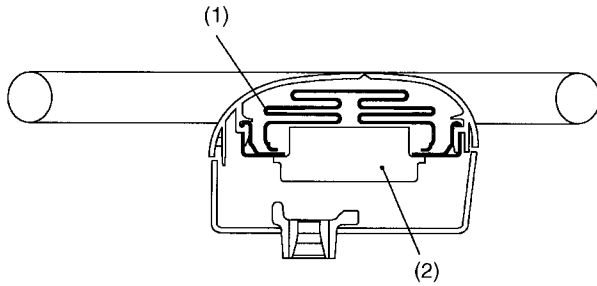

- (1) Airbag
- (2) Inflator (Driver)
- (3) Airbag module lid

Passenger's module

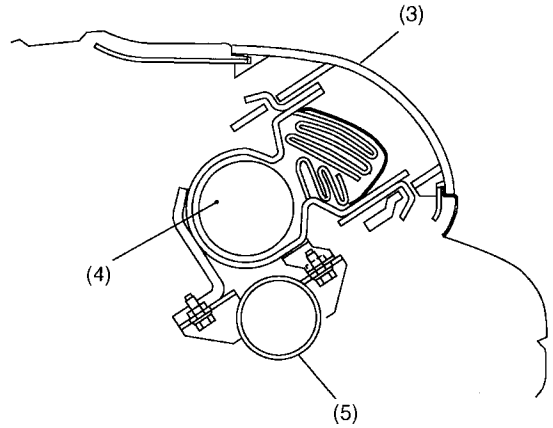

- (4) Dual-stage inflator (Passenger)
- (5) Steering support beam

B5H0823B

2. SIDE AIRBAG

A side airbag module is located at the outer side of each front seat backrest, and it contains an airbag and an inflator.

If a side-on collision occurs, the inflator produces a large volume of gas to inflate the airbag in a very short time.

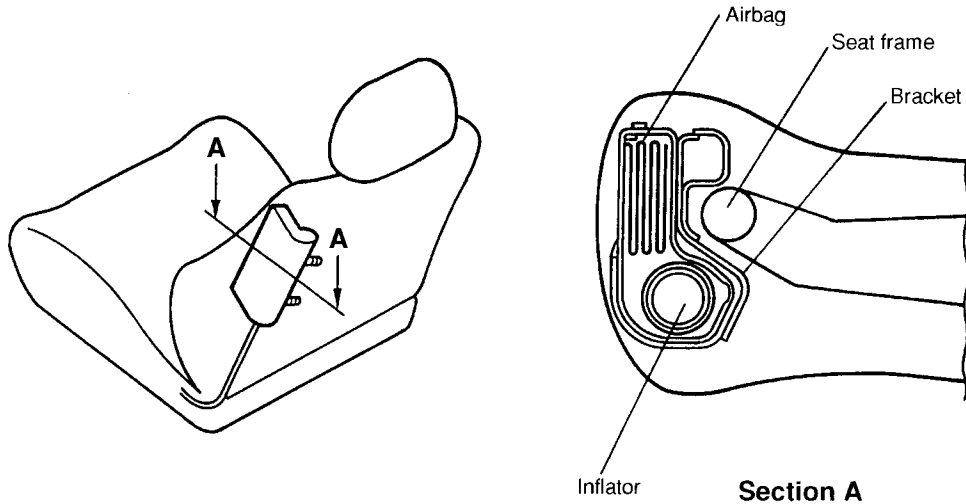

B5H0508A

F: AIRBAG CONNECTORS

1. DESCRIPTION

The airbag system uses connectors with a double lock mechanism and an incomplete coupling detection mechanism for enhanced reliability. If coupling is incomplete, the airbag warning light comes on in the combination meter.

2. AIRBAG HARNESS-TO-AIRBAG HARNESS CONNECTOR

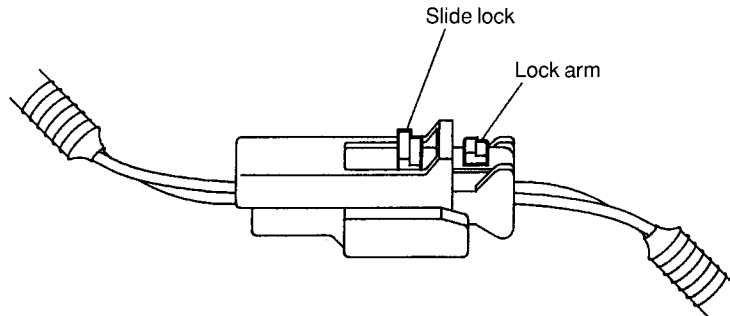

Disconnection:

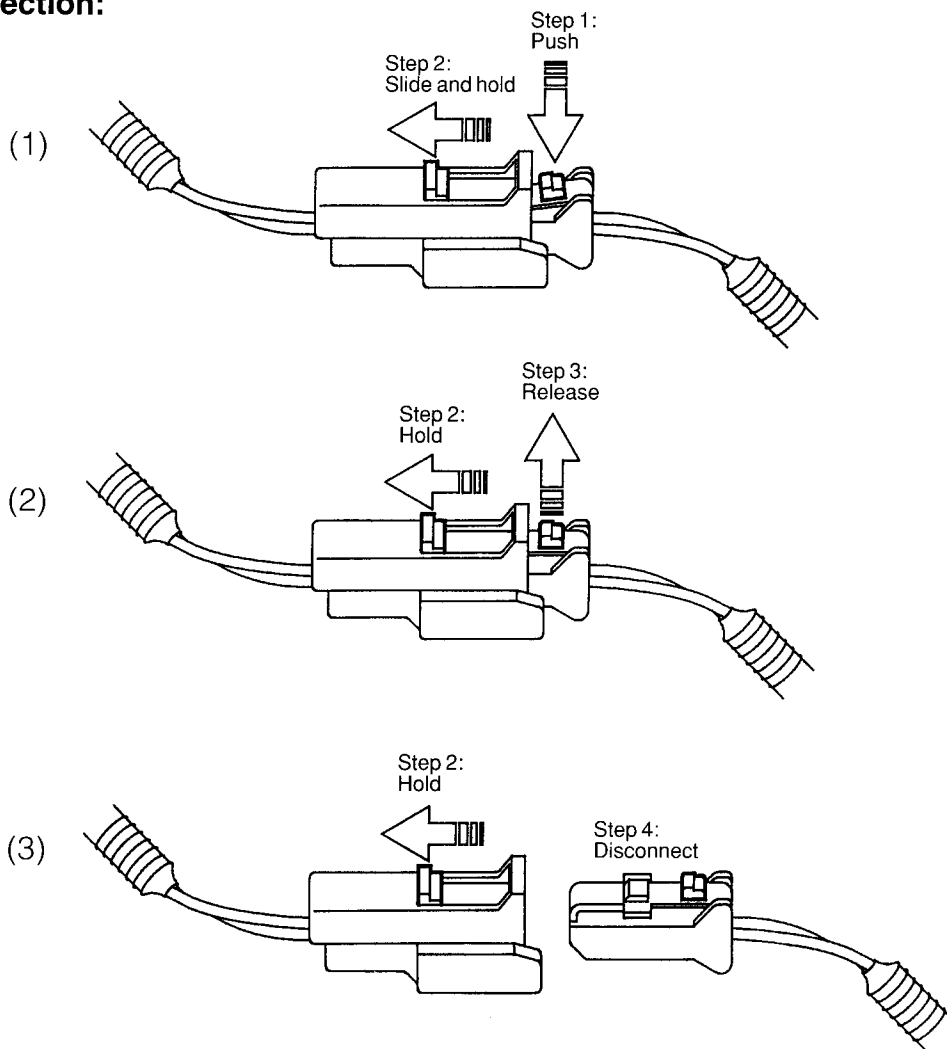

Connection:

Insert the male side connector half into the other until a "click" is heard.

CONSTRUCTION

3. AIRBAG HARNESS-TO-BODY HARNESS CONNECTOR

Disconnection:

Press the lever (A) to let the green lever (B) pop out. This unlocks the double lock mechanism. Then separate the connector halves by pulling them apart while pressing the lever (A).

Connection:

Insert the male side connector half into the other until a “click” is heard, then push in the green lever (B) until a “click” is heard. This engages the double lock mechanism.

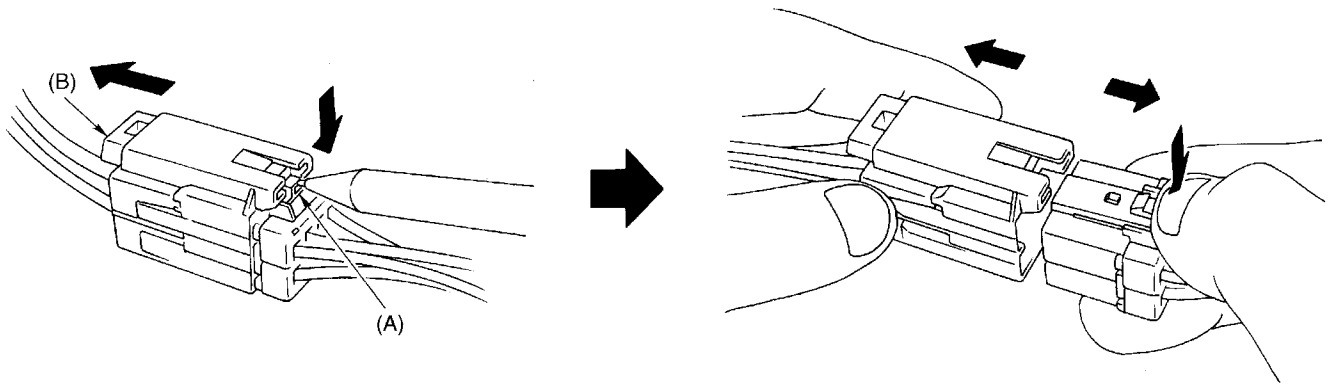

B5H0841A

4. FRONT SUB SENSOR AND SIDE AIRBAG SENSOR CONNECTORS

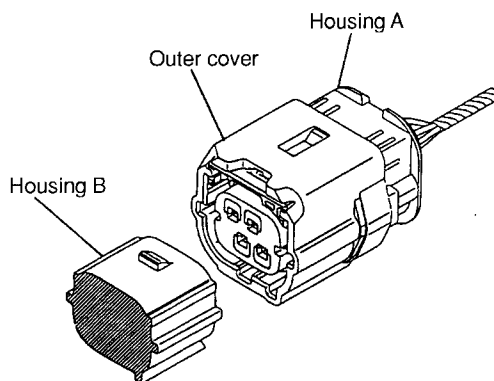

B5H1130A

Disconnection:

Step 1: Pull housing A in direction of arrow while pulling down outer cover.

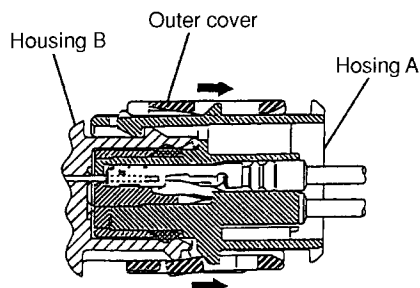

Step 2: Release lock of connector.

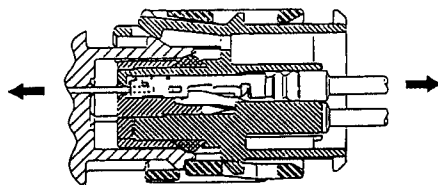

Step 3: Separate housing A and housing B.

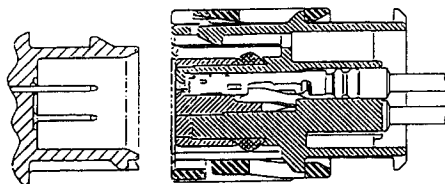

B5H1131A

Connection:

Insert housing B into housing A until a "click" is heard.

5. PASSENGER'S AIRBAG MODULE CONNECTOR

Disconnection:

Hold the pin insulator with one hand and the cover insulator with the other hand. Pull the cover insulator in the direction of the arrow in the drawing.

NOTE:

Do not hold the socket insulator when disconnecting the connector.

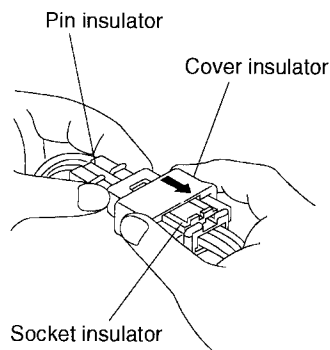

B5H1094A

Connection:

Step 1: Insert the socket insulator into the pin insulator such that the pin insulator's claw is pressed against the cover insulator.

NOTE:

Do not hold the cover insulator.

Step 2: Push the socket insulator forcibly toward the pin insulator. The cover insulator will move riding over the claw to complete engagement of the connector.

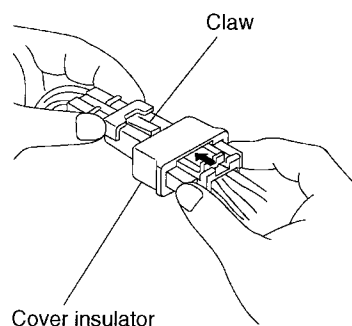

B5H1095A

G: STEERING ROLL CONNECTOR

The steering roll connector is located between the steering column and steering wheel. The connector contains a spirally wound flat cable. The cable can follow rotational movements of the steering wheel and ensures connection between the airbag module in the steering wheel and the airbag harness through which electrical signals are transmitted from the airbag control module.

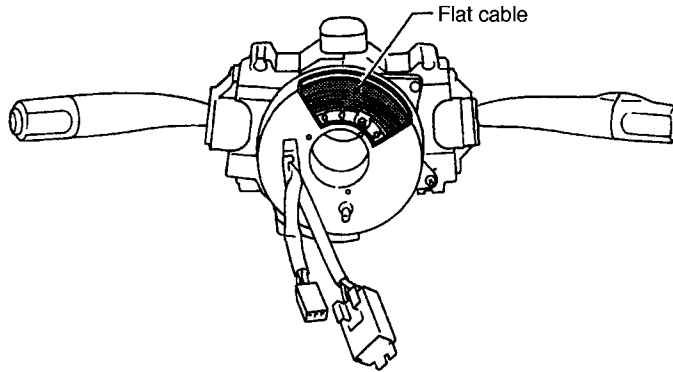

S5H0013A

H: AIRBAG WARNING LIGHT

The airbag warning light is located inside the combination meter. It illuminates if a poor connection in the airbag circuit occurs, or if the airbag control module detects an abnormal condition. When the airbag system is normal, this light comes on when the ignition switch is turned ON and then goes out about 7 seconds later.

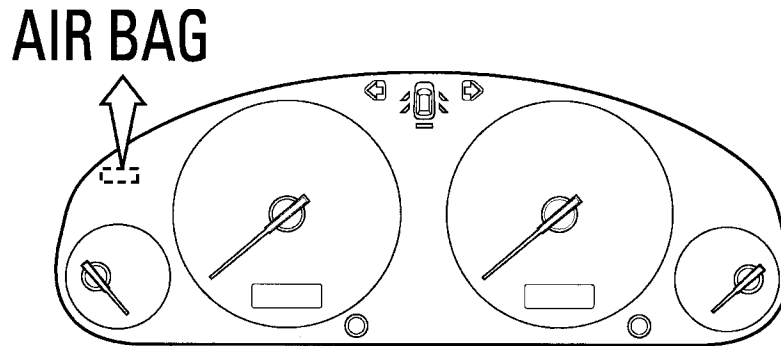

B5H0633

I: WIRE HARNESS

The wire harness of the airbag is entirely covered with a yellow protective tube, and can easily be distinguished from the other systems' harnesses.

CONSTRUCTION

Airbag System

J: LOCATIONS OF WARNING AND CAUTION LABELS

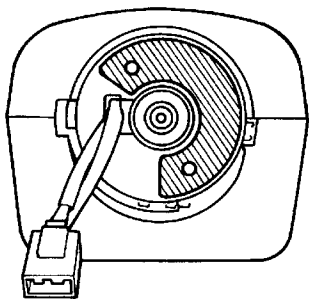
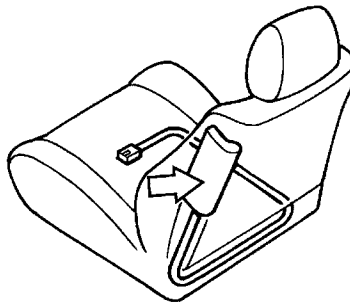
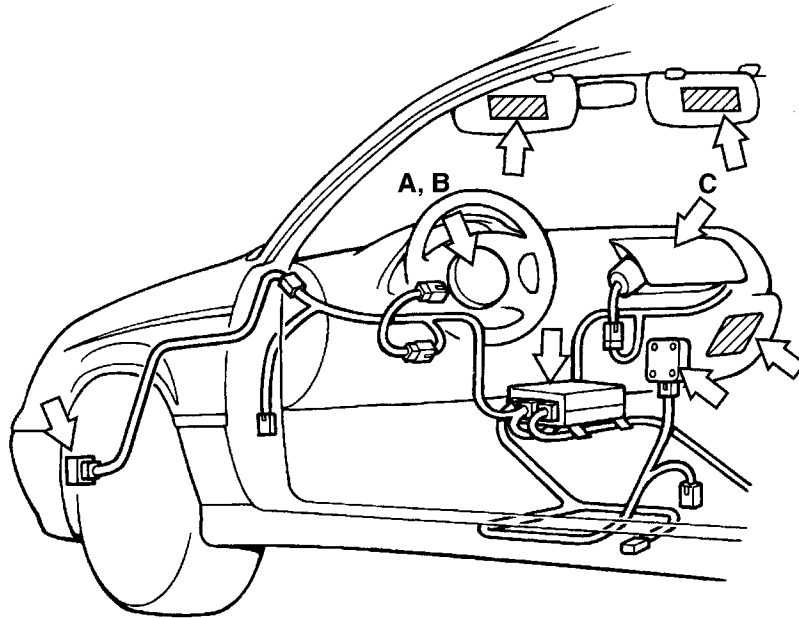

View A

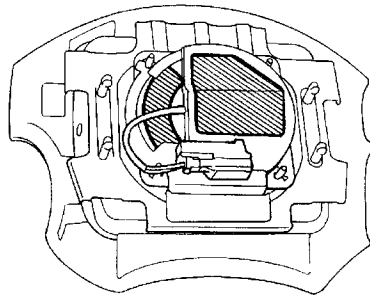

View B

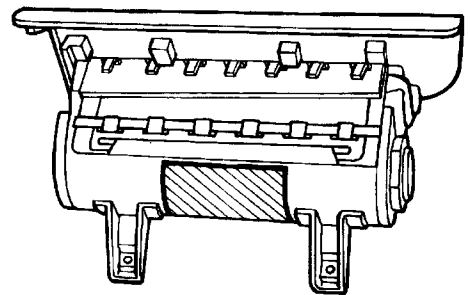

View C

B5H0842A