

1. General

A: OUTLINE

The automatic transmission comes in two types; one is for the models without a variable torque distribution (VTD) system (called “MPT models” – standing for multi-plate transfer models – in the following description), and the other for the models with a VTD system (called “VTD models” in the following description). Both the types are of a full-time all-wheel drive design, combining the torque converter/clutch section, final reduction section, automatic transmission section, and transfer section into a single unit (see “C: CROSS SECTIONAL VIEW”).

These transmissions are controlled electronically by the transmission control module (TCM). The TCM is a microprocessor-based unit that controls operation of various solenoid valves and other electric devices depending on many variables (throttle opening, vehicle speed, engine speed, selected gear range, etc.) to select the optimum gear and the most appropriate way of power transmission (including engine braking and lock-up clutch engagement) for a particular condition.

The TCM has an additional function of automatically selecting either of the two control patterns (“Base” and “Power”) in accordance with the driving type which it identifies from the rate of movement of the accelerator pedal. It uses the Base pattern typically for cruising on a flat road and the Power pattern during acceleration or up-hill driving.

1. MPT MODELS

- The automatic transmission for the MPT models has a transfer hydraulic pressure control unit. This unit is located at the rear of the automatic transmission section and consists of a duty-cycle-controlled solenoid valve which adjusts the hydraulic pressure applied to the wet multi-plate type transfer clutch.
- The TCM has in its memory a set of duty ratio data, each defining at what ratio the transfer clutch should transmit the torque for a particular driving condition. Based on the driving condition information it receives from the corresponding sensors (vehicle speed, throttle opening, gear range, slip of wheels, etc.), the TCM selects an appropriate duty ratio from the memory and uses it to control the solenoid valve. The solenoid valve then regulates the hydraulic pressure to the transfer clutch and the clutch is engaged to a degree determined by the hydraulic pressure.

2. VTD MODELS

- Electronically controlled and fully automatic, the four-speed transmission for the VTD models is called “E-4AT”. The center differential of this AWD transmission features the SUBARU drive power distribution system which combines a newly developed compound planetary gear set and an electronically controlled differential action limiting mechanism (limited slip differential or LSD). The system provides the vehicle with easy handling and stable operation features.
- The center differential distributes the drive torque to the front and rear wheels at a ratio of 45.5 : 54.5 through the torque dividing function of the compound planetary gear set. This ratio has been determined with emphasis on maximizing cornering smoothness (that requires optimizing distribution of the cornering forces generated between tires and road surface) rather than maximizing traction performance (that requires optimizing distribution of the dynamic loads). This front-rear torque distribution ratio (and, consequently, the cornering force distribution ratio) is variable due to the function of the electronically controlled differential action limiting mechanism. The range of the variation in the torque distribution ratio is from the ratio originally set for the compound planetary gears to the ratio attained when the differential gear set performs no differential action. This system capable of varying the torque distribution properly according to conditions enables the

driver to handle the vehicle easily even in a marginal condition and the vehicle to show improved driveability and stability in all road conditions.

B: FEATURES

1. MPT MODELS

- The transmission uses both structural and control means to reduce gearshift and engagement shocks; a one-way clutch and three accumulators effectively absorb shock loads, while fully electronic gear-shift control (1st through 4th), hydraulic pressure (line pressure) control and lock-up clutch control minimize chances of shock occurring.
- Both power transmission efficiency and fuel economy are improved by the use of a torque converter with hydraulically operated lock-up clutch and a gear train creating four forward and one reverse speeds with two sets of simple planetary gears.
- Apart from a highly rigid transmission case, the use of a push-pull cable for the selector lever mechanism improves quietness as the cable conveys vibration only slightly to the driver's control mechanism.
- The TCM has an on-board diagnosis function to facilitate servicing and a fail-safe control function to ensure minimum level of operation should an important problem occur in the system.
- The degree of engagement of the transfer clutch is accurately controlled by the TCM. This is especially effective to prevent undesirable tight corner braking which would occur when making a sharp turn at a low speed.
- Distribution of torque to the rear wheels is optimally controlled according to the engine output torque and selected gear. This improves fuel efficiency and directional stability.
- When the ABS is in operation, the TCM performs special control for the most effective braking by properly adjusting the degree of engagement of the transfer clutch and fixing the speed to a certain gear.
- The manual range feature enables the driver to hold the transmission in a desired gear. If used properly, it can improve driveability and ride comfort.

2. VTD MODELS

- The gearshift feeling is improved by optimally controlling the gearshift timing and the engine torque during gearshifts.
- Both power transmission efficiency and fuel economy are improved by the use of a torque converter with hydraulically operated lock-up clutch and a gear train creating four forward and one reverse speeds with two sets of simple planetary gears.
- The center differential combining compound planetary gears with an electronically controlled and hydraulically operated multi-plate differential action limiting device (limited slip differential) is a vehicle controllability enhancement feature that enables the vehicle to be handled easily even in a marginal condition.
- When the ABS is in operation, the TCM controls the differential action limiting device in such a way that the ABS can be controlled most appropriately in accordance with signals from the ABS system.
- The manual range feature enables the driver to hold the transmission in a desired gear. If used properly, it can improve driveability and ride comfort.
- The TCM has an on-board diagnosis function to facilitate servicing and a fail-safe control function to ensure minimum level of operation should an important problem occur in the system.

C: CROSS SECTIONAL VIEW

1. MPT MODELS

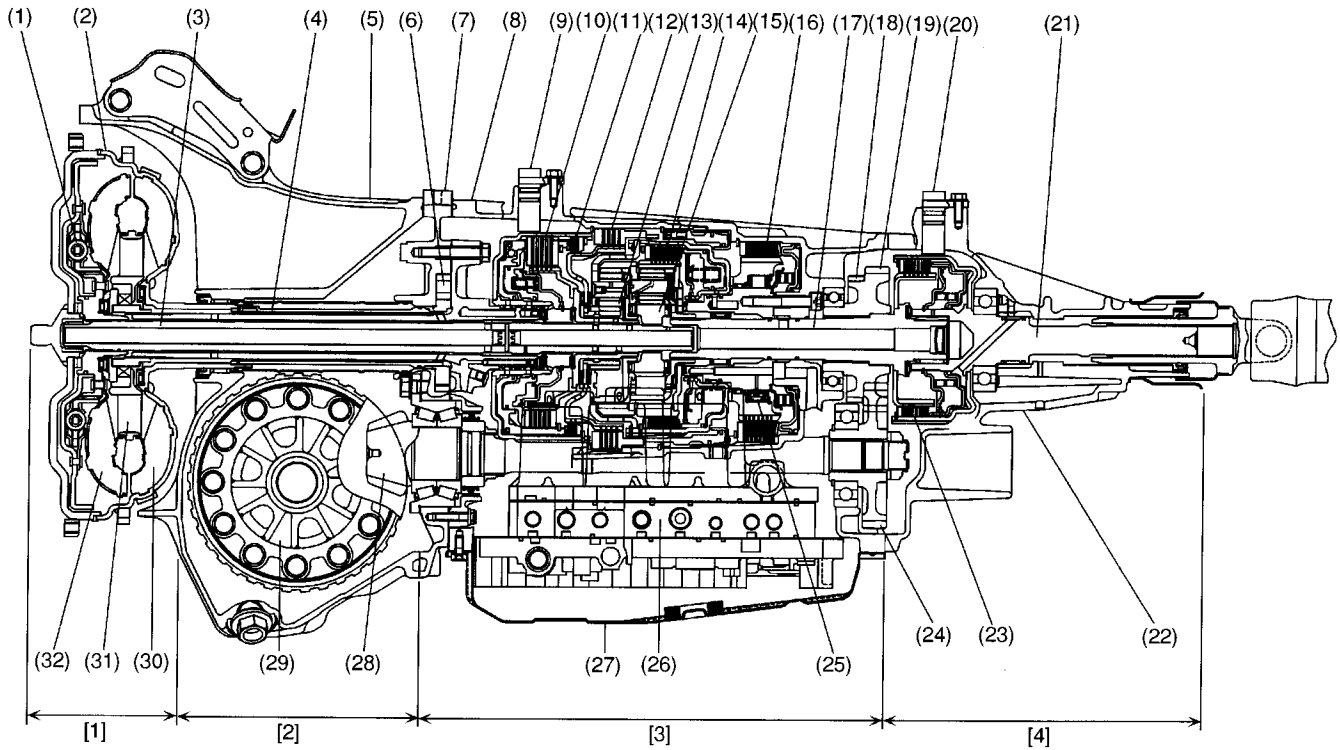

B3H0884A

(1) Lock-up damper	(9) Torque converter turbine speed sensor	(17) Reduction drive shaft	(25) One-way clutch	[1] Torque converter clutch section
(2) Torque converter clutch	(10) High clutch	(18) Parking gear	(26) Hydraulic control valve	
(3) Input shaft	(11) Reverse clutch	(19) Reduction drive gear	(27) Oil pan	[2] Final reduction section
(4) Oil pump drive shaft	(12) 2-4 brake	(20) Rear vehicle speed sensor	(28) Drive pinion shaft	
(5) Torque converter clutch case	(13) Front planetary gear	(21) Rear drive shaft	(29) Hypoid drive gear	[3] Automatic transmission section
(6) Oil pump	(14) Low clutch	(22) Extension case	(30) Impeller	
(7) Oil pump housing	(15) Rear planetary gear	(23) Transfer clutch	(31) Stator	[4] Transfer section
(8) Transmission case	(16) Low & reverse brake	(24) Reduction driven gear	(32) Turbine	

2. VTD MODELS

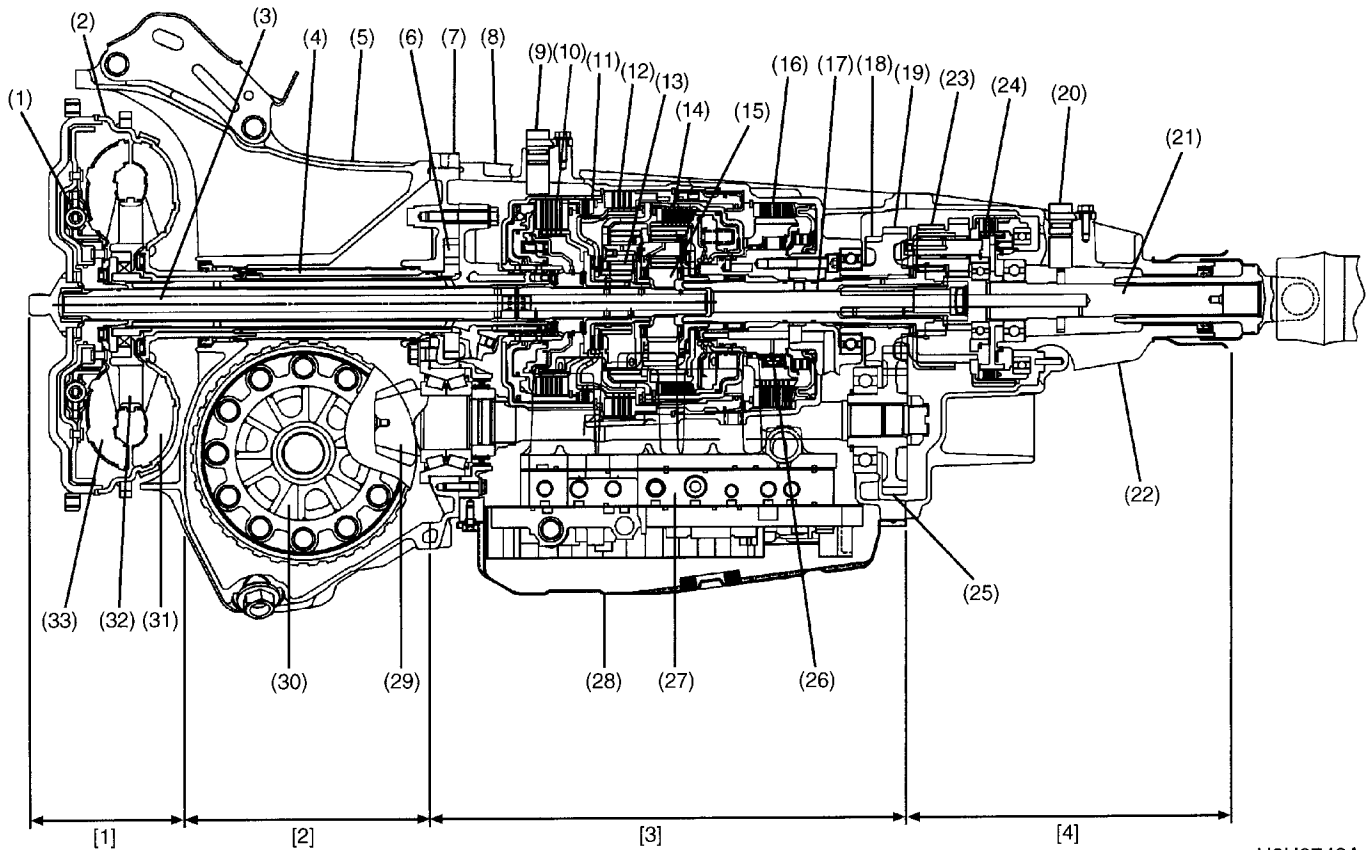

H3H0743A

(1) Lock-up damper	(10) High clutch	(19) Reduction drive gear	(28) Oil pan	[1] Torque converter clutch section
(2) Torque converter clutch	(11) Reverse clutch	(20) Rear vehicle speed sensor	(29) Drive pinion shaft	
(3) Input shaft	(12) 2-4 brake	(21) Rear drive shaft	(30) Hypoid drive gear	[2] Final reduction section
(4) Oil pump drive shaft	(13) Front planetary gear	(22) Extension case	(31) Impeller	
(5) Torque converter clutch case	(14) Low clutch	(23) Center differential	(32) Stator	[3] Automatic transmission section
(6) Oil pump	(15) Rear planetary gear	(24) Multi-plate clutch (LSD)	(33) Turbine	
(7) Oil pump housing	(16) Low & reverse brake	(25) Reduction driven gear		[4] Transfer section
(8) Transmission case	(17) Intermediate shaft	(26) One-way clutch		
(9) Torque converter turbine speed sensor	(18) Parking gear	(27) Hydraulic control valve		