

# REAR DRUM BRAKES

## 2. Rear Drum Brakes

- The rear drum brakes are of a leading-trailing shoe type. When fluid pressure is applied to each wheel cylinder, the piston expands the leading and trailing shoes. During expansion of the shoes, the lower shoe return spring joint acts as a pivot. The shoes come in contact with the inner surface of the drum, producing braking action.
- When brakes are applied during the forward movement, the tip of the brake leading shoe lining is pressed against the inner surface of the drum so as to oppose the drum's rotating force. This increases the braking force. The trailing shoe, however, undergoes a force that pushes it back so that braking force applied to the trailing shoe decreases. The above shoe actions are reverse while the vehicle is moving backward; the braking force exerted on the trailing shoe is greater than that on the leading shoe. This means that there is no difference in braking force between when the vehicle is moving forward and when it is reversing.
- An inspection hole is provided in the backing plate for easier inspection of the linings for wear. The hole is closed with a rubber cap.

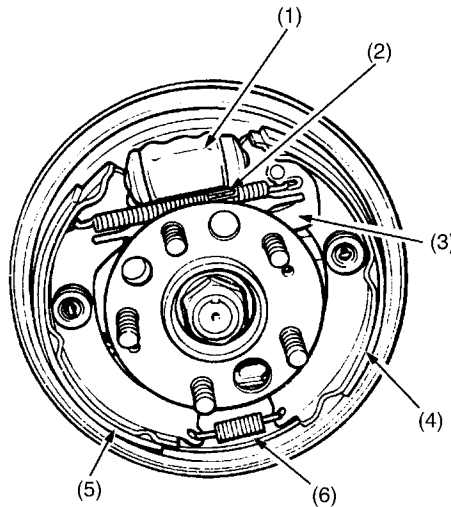

B4H1628B

- |                              |                              |
|------------------------------|------------------------------|
| (1) Wheel cylinder           | (4) Trailing shoe            |
| (2) Upper shoe return spring | (5) Leading shoe             |
| (3) Adjuster lever           | (6) Lower shoe return spring |

## A: AUTOMATIC ADJUSTER

The brake lining-to-drum clearance is automatically adjusted by the automatic adjuster. When the brake shoe is contracting after expansion, the adjuster lever rotates the adjuster assembly's screw to lengthen the adjuster assembly so that the clearance is maintained at the specified value.

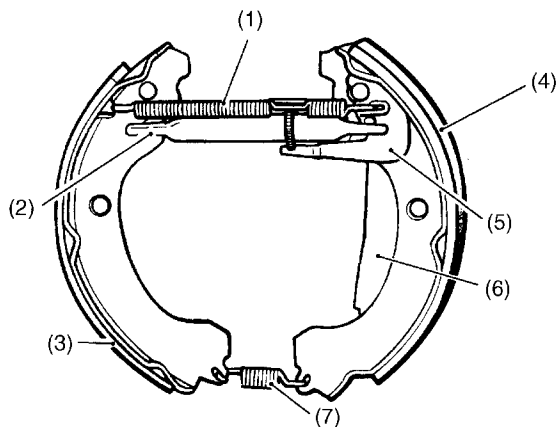

S4H0340A

- |                              |                              |
|------------------------------|------------------------------|
| (1) Upper shoe return spring | (5) Adjuster lever           |
| (2) Adjuster assembly        | (6) Parking lever            |
| (3) Leading shoe             | (7) Lower shoe return spring |
| (4) Trailing shoe            |                              |