

2. Cooling Circuits

The cooling system operates in three different phases depending on the temperature of the engine coolant.

- 1st phase (thermostat closed)

When the engine coolant temperature is below 76°C (169°F), the thermostat remains closed. The coolant flows through the bypass and heater circuits.

This permits the engine to warm up quickly.

- 2nd phase (thermostat open)

When the engine coolant temperature is above 76 – 80°C (169 – 176°F), the thermostat opens. The coolant flows through the radiator where it is cooled.

- 3rd phase (thermostat open and radiator fan operating)

When the engine coolant temperature sensor sends a signal indicating a temperature above 95°C (203°F) to the ECM, it causes the radiator fan (or fans) to operate.

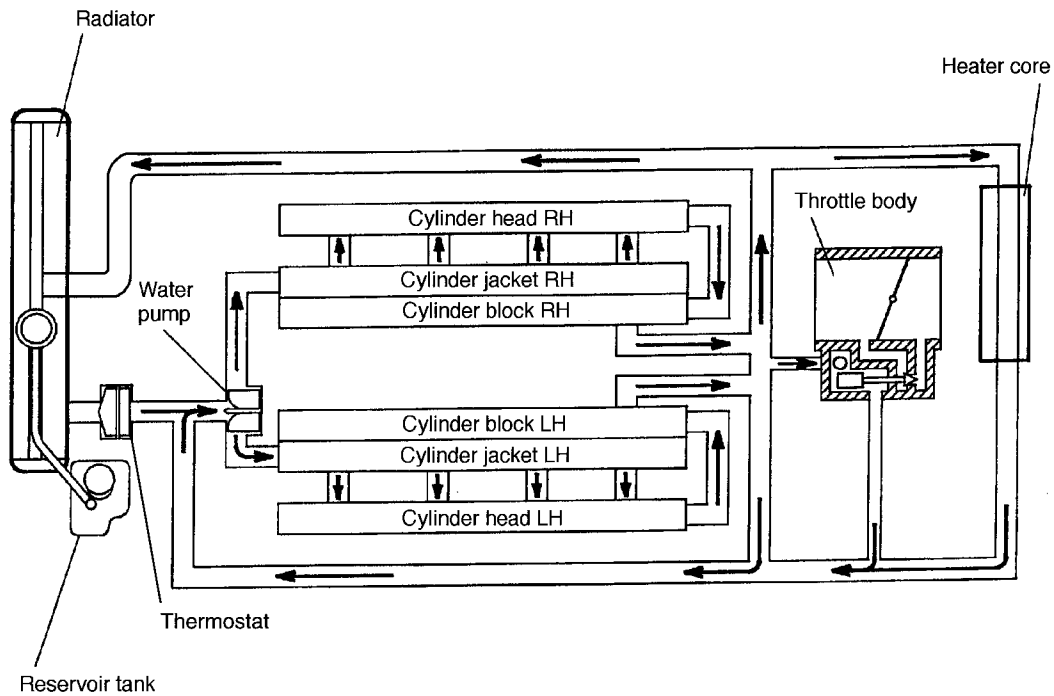

B2H2915B