

PROPELLER SHAFT

1. Propeller Shaft

The propeller shaft uses constant velocity joints for quiet operation of the driveline components. The center joint is a double offset joint (DOJ) type which can extend and retract in the axial directions.

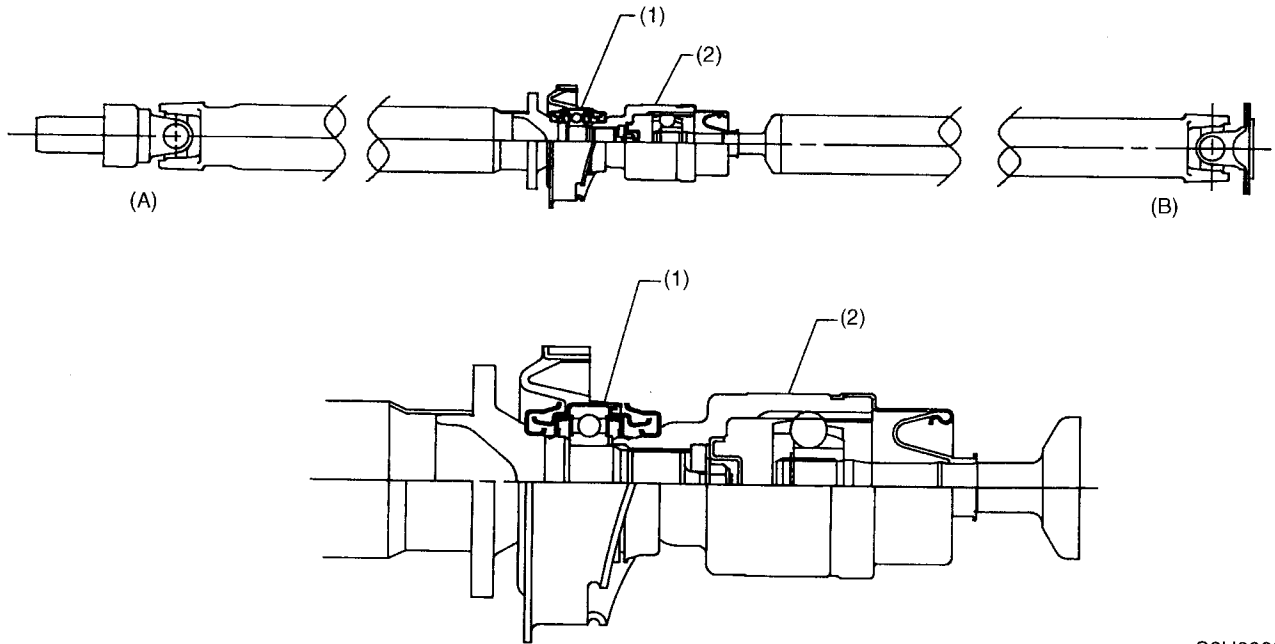

(1) Center bearing

(2) Double offset joint (DOJ)

(A) Transmission side

(B) Rear differential side

S3H0008B