

2. Front Axle

A: GENERAL

- The inboard end of each axle shaft is connected to the transmission via a constant velocity joint (shudder-less freering tripod joint: SFJ) which is flexible in the axial directions while the outboard end is connected via a bell joint (BJ) to the wheel hub which is supported by a taper roller bearing located inside the axle housing. The BJ features a large operating angle. Both the constant velocity joints (SFJ and BJ) ensure smooth, regular rotation of the drive wheels with minimum vibration.
- The bearing is a preloaded, non-adjustable tapered roller unit bearing. Each hub is fitted in the axle housing via the tapered roller bearing.
- The BJ's spindle is splined to the hub and is secured with an axle nut clinched to it.
- The disc rotor is an external mounting type. It is secured to the disc wheel using hub bolts to facilitate maintenance of the disc rotor.

1) 3.0ℓ ENGINE MODEL

- The hubs are induction-hardened.
- The axle nuts are given chromate treatment (olive drab treatment).
- The bearings are specially designed for the 3.0ℓ engine model.

2) 2.5ℓ ENGINE MODEL

- The hubs are same as those used in the previous model.
- The axle nuts are zinc-plated.
- The bearings are same as those used in the previous model.

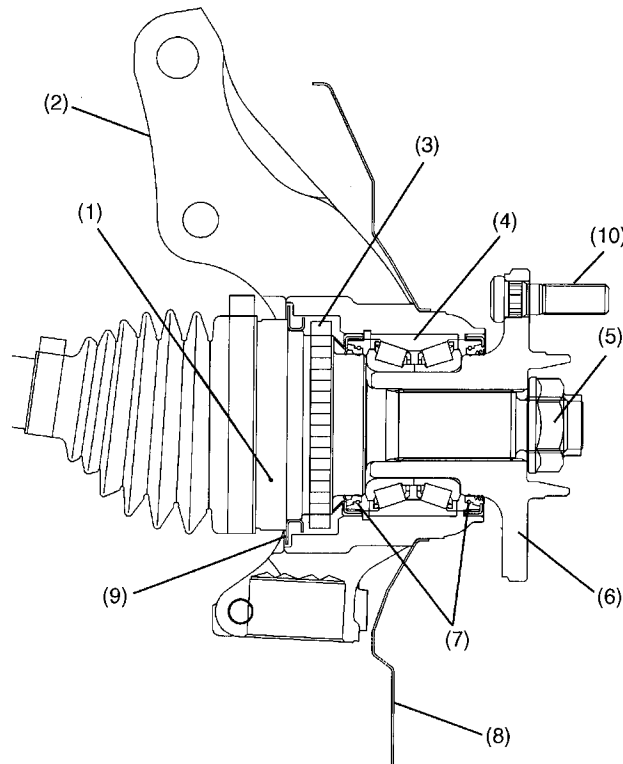

B4H2192A

- | | | |
|---------------------|-------------------------|------------------|
| (1) Bell joint (BJ) | (5) Axle nut | (9) Baffle plate |
| (2) Axle housing | (6) Hub | (10) Hub bolt |
| (3) Tone wheel | (7) Oil seal | |
| (4) Bearing | (8) Brake backing plate | |

B: FRONT DRIVE SHAFT

- A shudder-less freering tripod joint (SFJ) is used on the differential side of each front drive shaft. The SFJ can be disassembled for maintenance. It provides a maximum operating angle of 25° and can be moved in the axial directions.
- A bell joint (BJ) is used on the wheel side of each front drive shaft. The BJ's maximum operating angle is 47.5°.

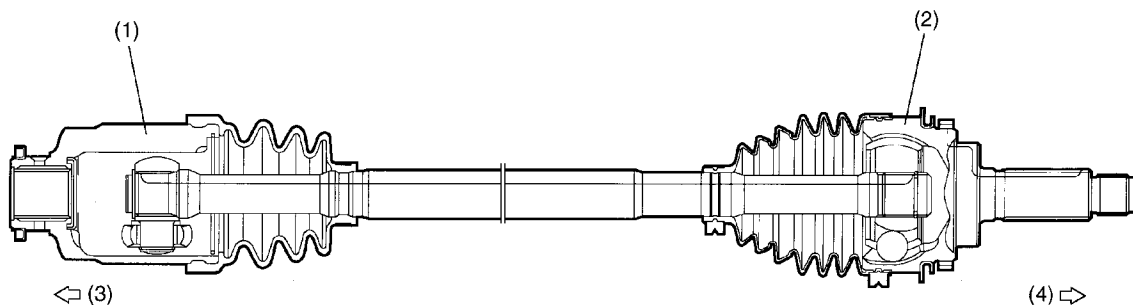

B4H2193B

- | | |
|--|-----------------------|
| (1) Shudder-less freering tripod joint (SFJ) | (3) Transmission side |
| (2) Bell joint (BJ) | (4) Wheel side |