

### 5. Sensors and Switches

#### A: FRONT OXYGEN (A/F) SENSOR

- The front oxygen sensor uses zirconium oxide ( $ZrO_2$ ) which is a solid electrolyte, at portions exposed to exhaust gas.
- The zirconium oxide has the property of generating electromotive force when its both sides are exposed to oxygen ions of different concentration and the magnitude of this electromotive force depends on how much the difference is.
- The front oxygen sensor detects the amount of oxygen in exhaust gases by making use of this property of the zirconium oxide material.
- The zirconium oxide material is formed into a closed end tube and its external surface is exposed to exhaust gases with smaller oxygen ion concentration, whereas its internal surface is exposed to atmospheric air. The external surface has a porous platinum coating. The sensor housing is grounded to the exhaust pipe and the inside is connected to the ECM through the harness to be able to use the current output from the sensor.
- The sensor incorporates a ceramic heater to improve its performance at low temperatures.

#### MT VEHICLES

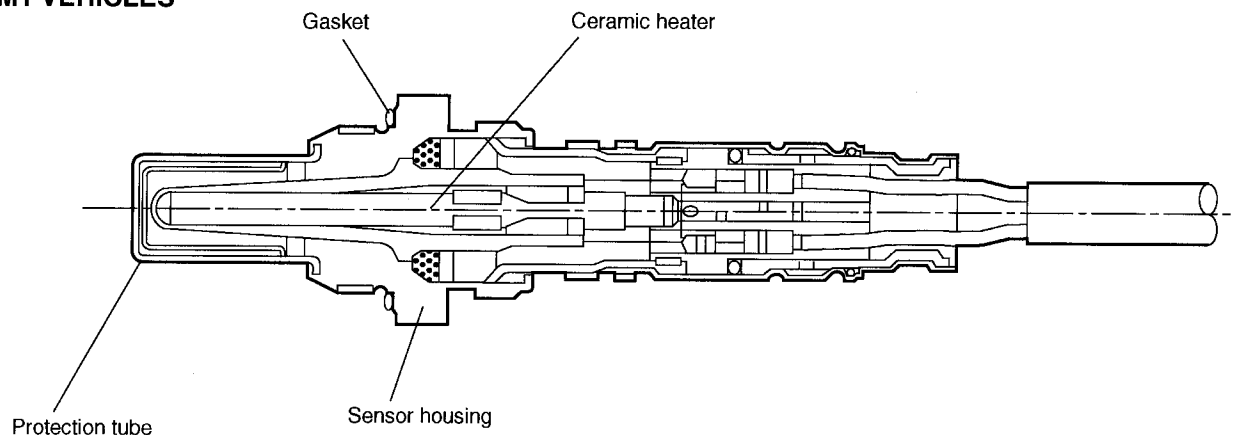

#### AT VEHICLES

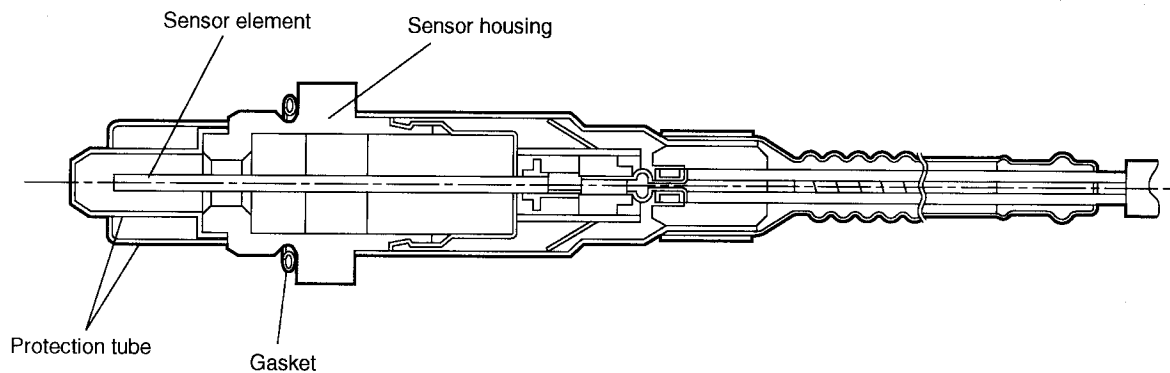

B2H3443A

- When rich air-fuel mixture is burnt in the cylinder, the oxygen in the exhaust gases is almost completely used in the catalytic reaction by the platinum coating on the external surface of the zirconia tube. This results in a very large difference in the oxygen ion concentration between the inside and outside of the tube, and the electromotive force generated is large.
- When a lean air-fuel mixture is burnt in the cylinder, relatively large amount of oxygen remains in the exhaust gases even after the catalytic action, and this results in a small difference in the oxygen ion concentration between the tube's internal and external surfaces. The electromotive force in this case is very small.
- The difference in oxygen concentration changes drastically in the vicinity of the stoichiometric air-fuel ratio, and hence the change in the electromotive force is also large. By using this information, the ECM can determine the air-fuel ratio of the supplied mixture easily. The front oxygen sensor does not generate much electromotive force when the temperature is low. The output characteristics of the sensor stabilize at a temperature of approximately 700°C (1,292°F).

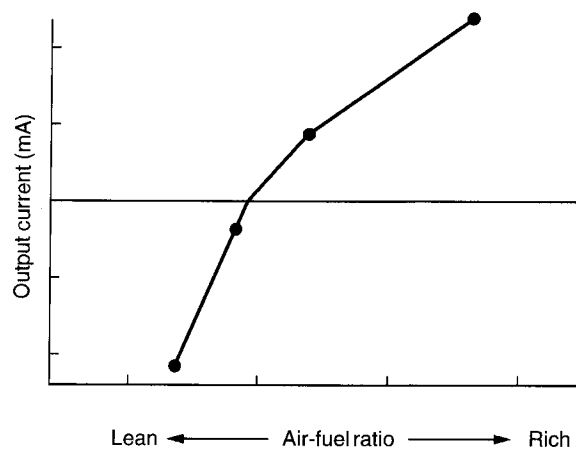
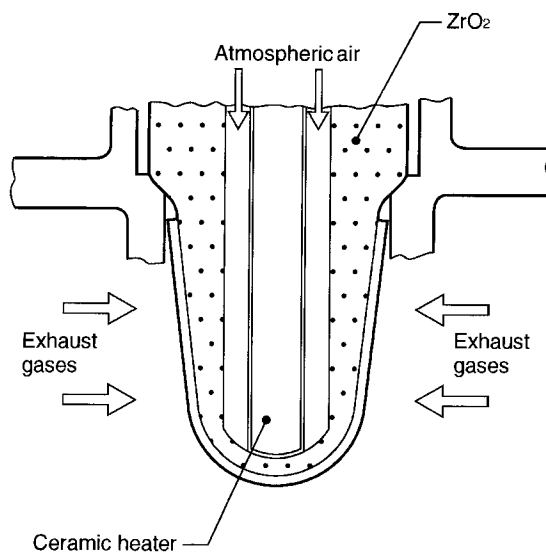

B2H2006B

# SENSORS AND SWITCHES

## Fuel Injection (Fuel System)

### B: REAR OXYGEN SENSOR

- The rear oxygen sensor is used to sense oxygen concentration in the exhaust gas. If the air-fuel ratio is leaner than the stoichiometric ratio in the mixture (i.e., excessive amount of air), the exhaust gas contains more oxygen. To the contrary, if the fuel ratio is richer than the stoichiometric ratio, the exhaust gas contains almost no oxygen.
- Detecting the oxygen concentration in exhaust gas using the oxygen sensor makes it possible to determine whether the air-fuel ratio is leaner or richer than the stoichiometry.
- The rear oxygen sensor has a zirconia tube (ceramic) which generates voltage if there is a difference in oxygen ion concentration between the inside and outside of the tube. Platinum is coated on the inside and outside of the zirconia tube as a catalysis and electrode material. The sensor housing is grounded to the exhaust pipe and the inside is connected to the ECM through the harness.
- A ceramic heater is employed to improve performance at low temperatures.

#### MT VEHICLES

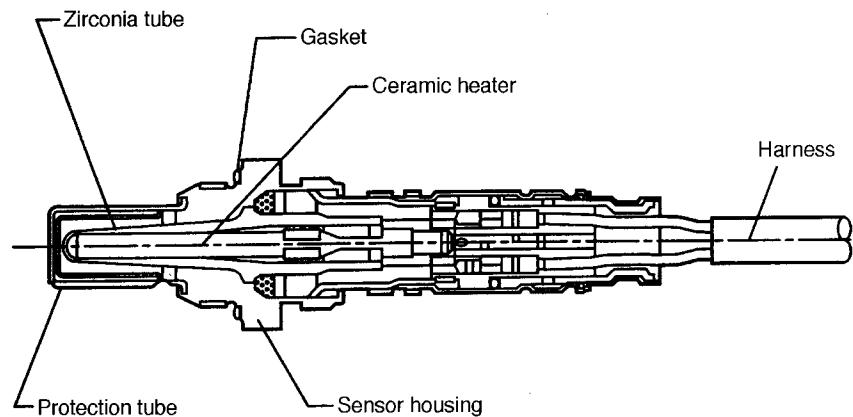

B2H1993B

#### AT VEHICLES

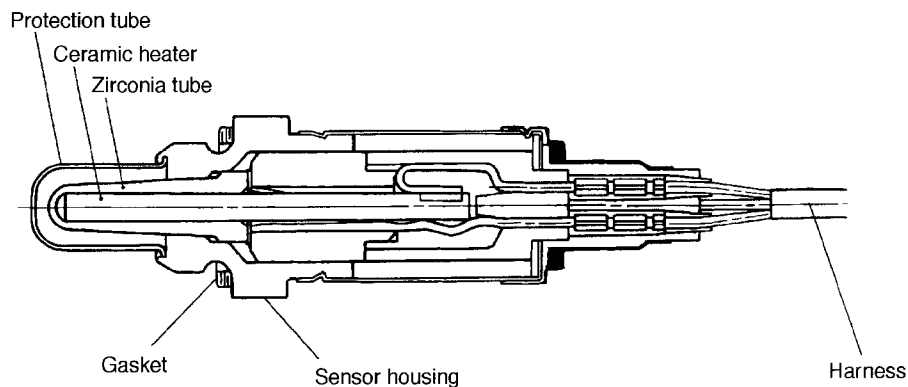

B2H3810A

- When rich air-fuel mixture is burnt in the cylinder, the oxygen in the exhaust gases is almost completely used in the catalytic reaction by the platinum coating on the external surface of the zirconia tube. This results in a very large difference in the oxygen ion concentration between the inside and outside of the tube, and the electromotive force generated is large.
- When a lean air-fuel mixture is burnt in the cylinder, relatively large amount of oxygen remains in the exhaust gases even after the catalytic action, and this results in a small difference in the oxygen ion concentration between the tube's internal and external surfaces. The electromotive force in this case is very small.
- The difference in oxygen concentration changes drastically in the vicinity of the stoichiometric air-fuel ratio, and hence the change in the electromotive force is also large. By using this information, the ECM can determine the air-fuel ratio of the supplied mixture easily. The rear oxygen sensor does not generate much electromotive force when the temperature is low. The output characteristics of the sensor stabilize at a temperature of approximately 300 to 400°C (572 to 752°F).

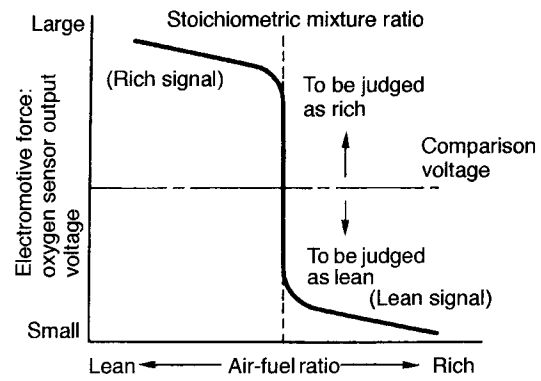
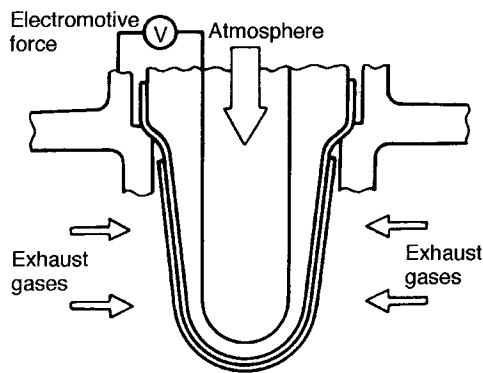

G2H0038B

# SENSORS AND SWITCHES

Fuel Injection (Fuel System)

## C: ENGINE COOLANT TEMPERATURE SENSOR

- The engine coolant temperature sensor is located on the engine coolant pipe. The sensor uses a thermistor whose resistance changes inversely with temperature. Resistance signals as engine coolant temperature information are transmitted to the ECM to make fuel injection, ignition timing, purge control solenoid valve and other controls.

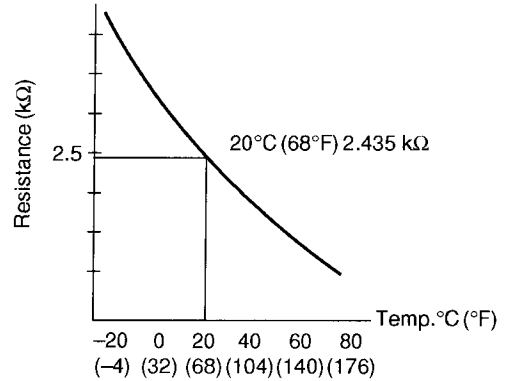
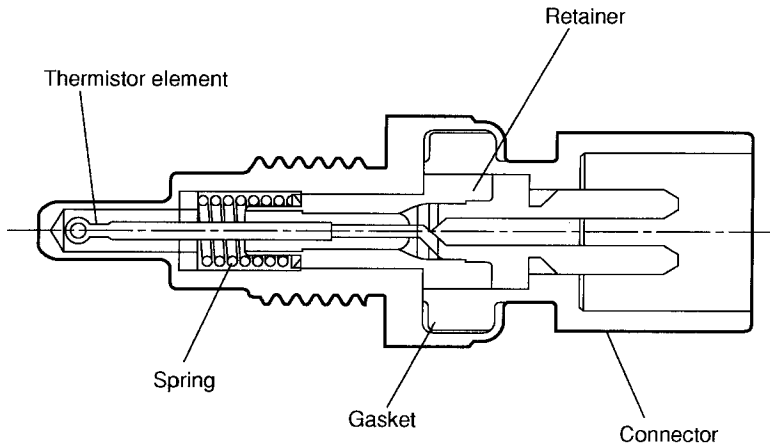

B2H3452A

## D: CRANKSHAFT POSITION SENSOR

### 1. MT VEHICLES

- The crankshaft position sensor is installed on the oil pump which is located in the front center portion of the cylinder block. The sensor generates a pulse when one of the teeth on the perimeter of the crankshaft sprocket (rotating together with the crankshaft) passes in front of it. The ECM determines the crankshaft angular position by counting the number of pulses.
- The crankshaft position sensor is a molded type which consists of a magnet, core, coil, terminals and other components as illustrated below.

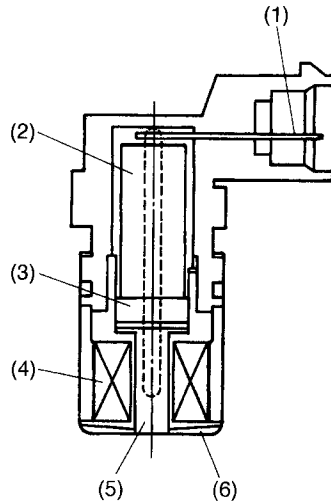

B2H0407B

- |               |           |
|---------------|-----------|
| (1) Terminal  | (4) Coil  |
| (2) Yoke core | (5) Core  |
| (3) Magnet    | (6) Cover |

- As the crankshaft rotates, each tooth aligns with the crankshaft position sensor. At that time, the magnetic flux in the sensor's coil changes since the air gap between the sensor pickup and the sprocket changes. This change in magnetic flux induces a voltage pulse in the sensor and the pulse is transmitted to the ECM.

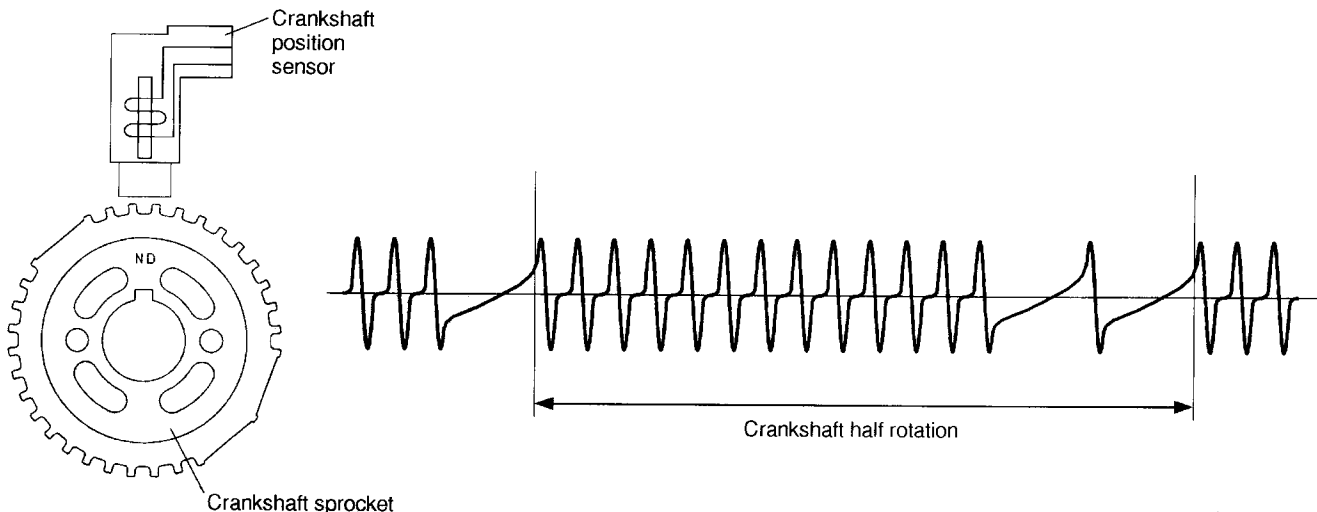

B2H3811A

# SENSORS AND SWITCHES

## Fuel Injection (Fuel System)

### 2. AT VEHICLES

- The crankshaft position sensor is installed on the oil pump which is located in the front center portion of the cylinder block. The sensor generates a pulse when one of the teeth on the perimeter of the crankshaft sprocket (rotating together with the crankshaft) passes in front of it. The ECM determines the crankshaft angular position by counting the number of pulses.
- The crankshaft position sensor is a molded type which consists of a magnet, core, coil, terminals and other components as illustrated below.

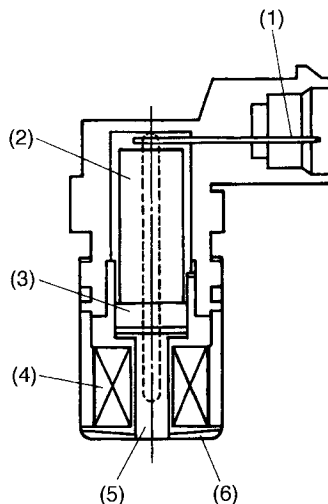

B2H0407B

- |               |           |
|---------------|-----------|
| (1) Terminal  | (4) Coil  |
| (2) Yoke core | (5) Core  |
| (3) Magnet    | (6) Cover |

- As the crankshaft rotates, each tooth aligns with the crankshaft position sensor. At that time, the magnetic flux in the sensor's coil changes since the air gap between the sensor pickup and the sprocket changes. This change in magnetic flux induces a voltage pulse in the sensor and the pulse is transmitted to the ECM.

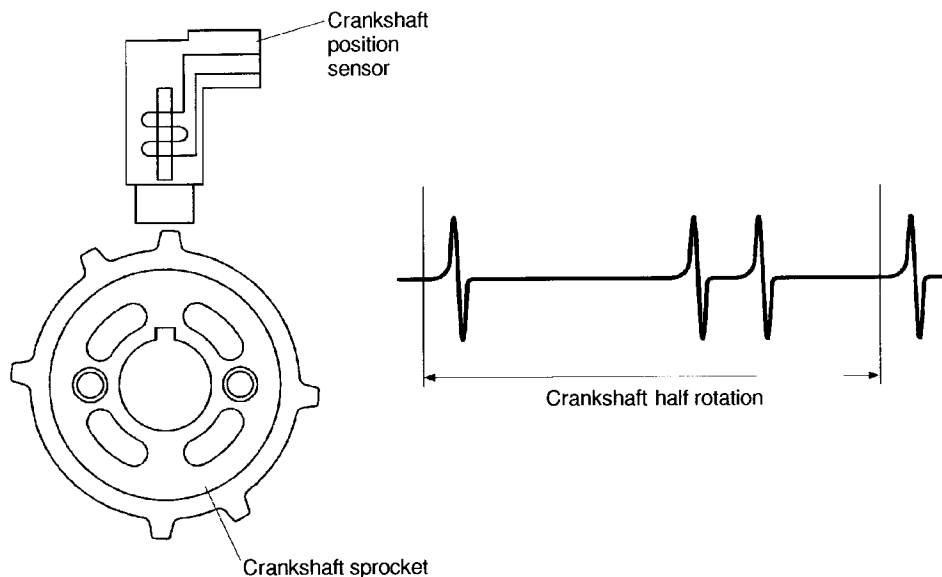

B2H1995A

## E: CAMSHAFT POSITION SENSOR

### 1. MT VEHICLES

- The camshaft position sensor is located on the left-hand camshaft support. It detects the combustion cylinder at any given moment.
  - The sensor generates a pulse when one of the bosses on the back of the left-hand camshaft drive sprocket passes in front of the sensor. The ECM determines the camshaft angular position by counting the number of pulses.
- Internal construction and the basic operating principle of the camshaft position sensor are similar to those of the crankshaft position sensor. Two bosses are provided on the sprocket as shown below.

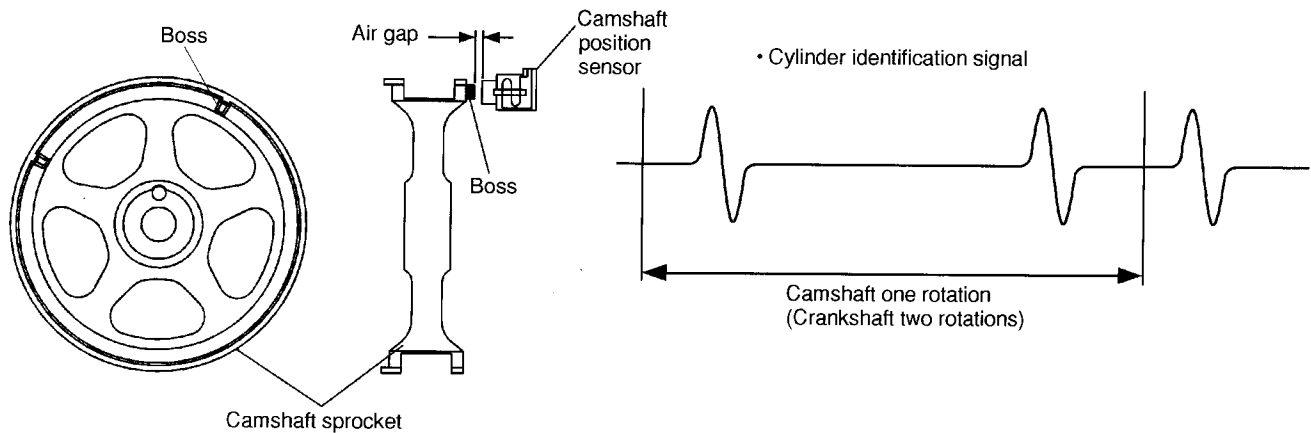

B2H1996B

### 2. AT VEHICLES

- The camshaft position sensor is located on the left-hand camshaft support. It detects the combustion cylinder at any given moment.
  - The sensor generates a pulse when one of the bosses on the back of the left-hand camshaft drive sprocket passes in front of the sensor. The ECM determines the camshaft angular position by counting the number of pulses.
- Internal construction and the basic operating principle of the camshaft position sensor are similar to those of the crankshaft position sensor. A total of seven bosses are arranged at equally spaced four locations (one each at two locations, two at one location, and three at one location) of the sprocket as shown below.

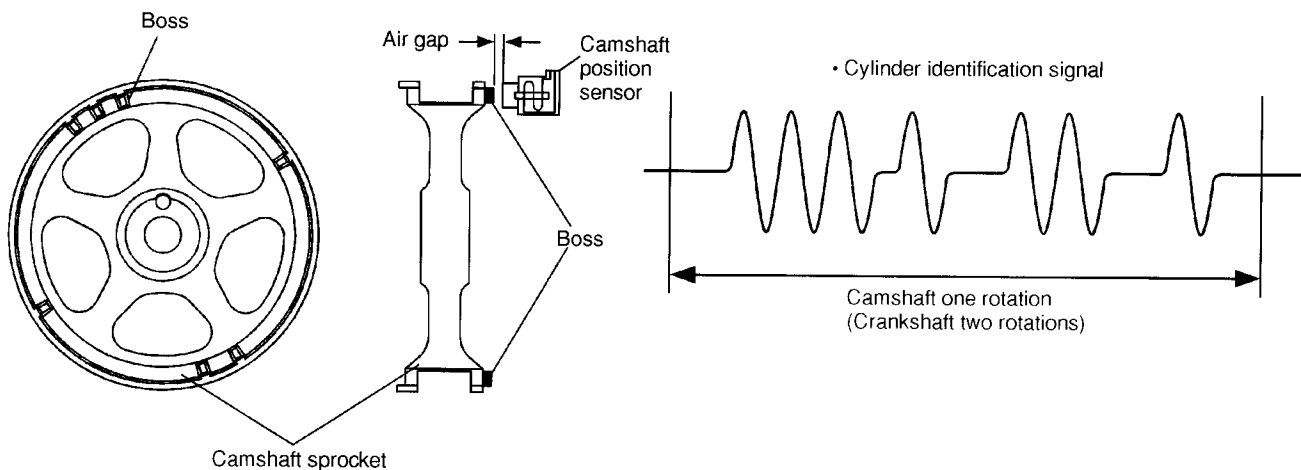

B2H3812B



# SENSORS AND SWITCHES

## Fuel Injection (Fuel System)

### F: KNOCK SENSOR

- The knock sensor is installed on the cylinder block, and senses knocking that occurs in the engine.
- The sensor is a piezo-electric type which converts vibration resulting from knocking into electric signals.
- In addition to a piezo-electric element, the sensor has a weight and case as its components. If knocking occurs in the engine, the weight in the case moves causing the piezo-electric element to generate a voltage.
- The knock sensor harness is connected to the bulkhead harness.

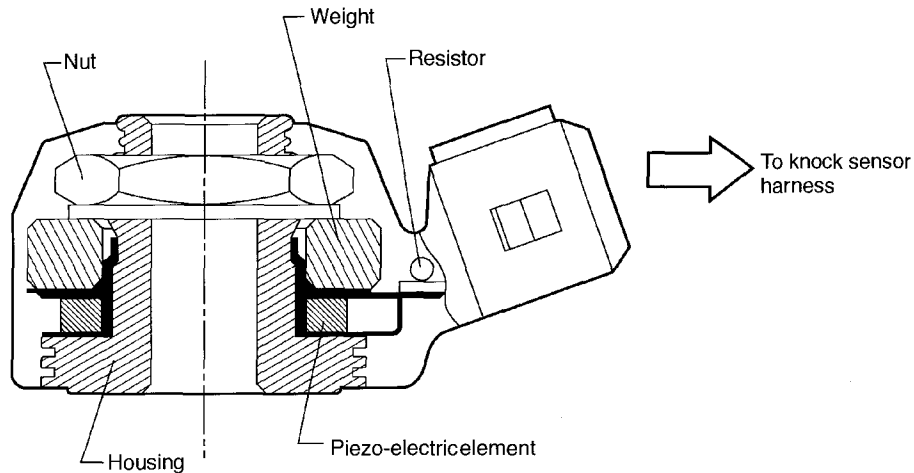

B2H1998C

## G: VEHICLE SPEED SENSOR

### 1. MT VEHICLES

- The vehicle speed sensor is mounted on the transmission.
- The vehicle speed sensor generates a 4-pulse signal for every rotation of the front differential and send it to the ECM and the combination meter.

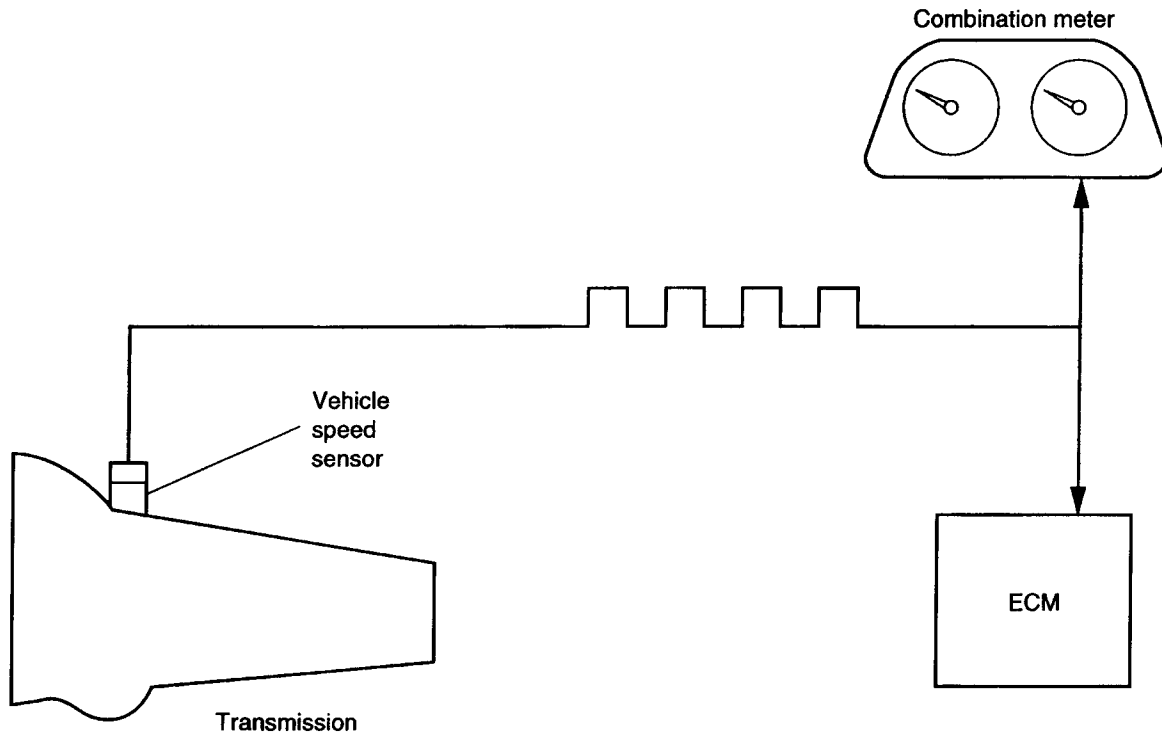

B2H2458B

# SENSORS AND SWITCHES

Fuel Injection (Fuel System)

## 2. AT VEHICLES

- The vehicle speed sensor is mounted on the transmission.
- The vehicle speed sensor generates a 16-pulse signal for every rotation of the front differential and send it to the transmission control module (TCM). The signal sent to the TCM is converted there into a 4-pulse signal, and then sent to the ECM and the combination meter.

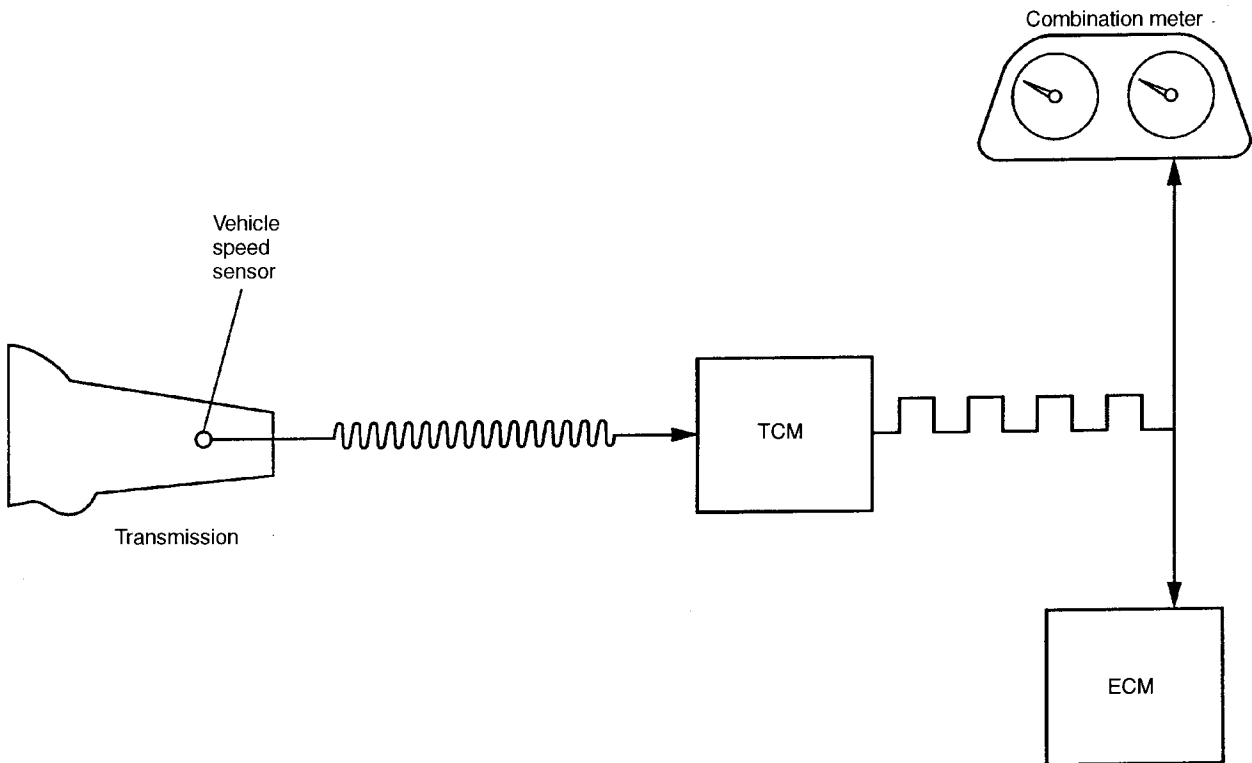

B2H2459C