

3. Fuel Line

A: GENERAL

- The fuel pressurized by the fuel tank inside pump is delivered to each fuel injector by way of the fuel pipe and fuel filter. Fuel injection pressure is regulated to an optimum level by the pressure regulator.
- Each injector injects fuel into the intake port of the corresponding cylinder where the fuel is mixed with air. The mixture then enters the cylinder.

Fuel injection amount and timing are regulated by the ECM.

FUEL LINE

Fuel Injection (Fuel System)

B: PRESSURE REGULATOR

The pressure regulator is installed at the injector end of the fuel supply line. It has a fuel chamber and spring chamber separated by a diaphragm. Fuel chamber is connected to the fuel supply line and the spring chamber is connected to the intake manifold. Fuel chamber also has a relief valve connected to the fuel return line through which fuel returns to the fuel tank. When the intake manifold vacuum increases, the diaphragm is pulled and the relief valve opens to decrease the fuel supply line pressure (or fuel injection pressure). When the intake manifold vacuum decreases, the diaphragm is pushed by the spring to increase the fuel supply line pressure. Thus, the difference between the fuel injection pressure and the intake manifold vacuum is kept at a constant level of 294 kPa (3.00 kg/cm², 43.0 psi) for MT vehicles or 299.1 kPa (3.05 kg/cm², 43.4 psi) for AT vehicles to precisely control the amount of injected fuel.

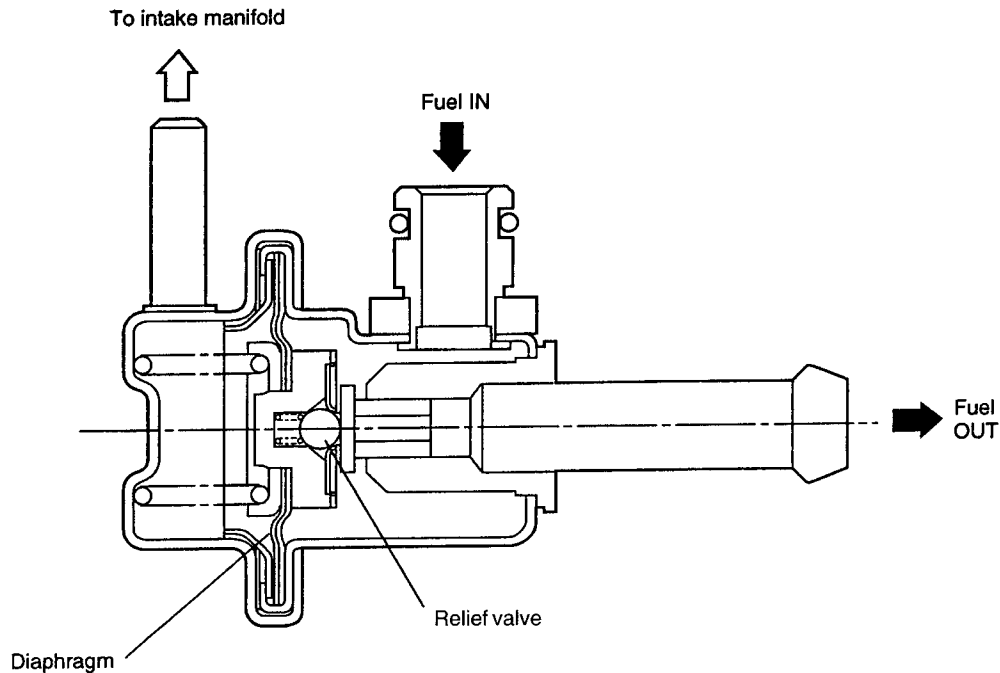

S2H0623B

C: FUEL INJECTORS

- The MFI system employs top feed type fuel injectors with an air assist feature.
- Each injector is installed in the fuel pipe in such a way that the injector is cooled by fuel.
- The features of this type of fuel injector are as follows:
 - 1) High heat resistance
 - 2) Low driving noise
 - 3) Easy to service
 - 4) Small size
- The injector injects fuel according to the valve open signal from the ECM. The needle valve is lifted by the solenoid which is energized on arrival of the valve open signal.
- Since the injector's nozzle hole area, the lift of valve and the fuel pressure are kept constant, the amount of fuel injected is controlled only by varying the duration of the valve open signal from the ECM.
- Fuel atomization is enhanced using assist air supplied from the idle air control solenoid valve passing through the passage formed in the intake manifold at the area in which each injector is installed. This contributes not only to higher combustion efficiency and higher output but also to cleaner exhaust emissions.

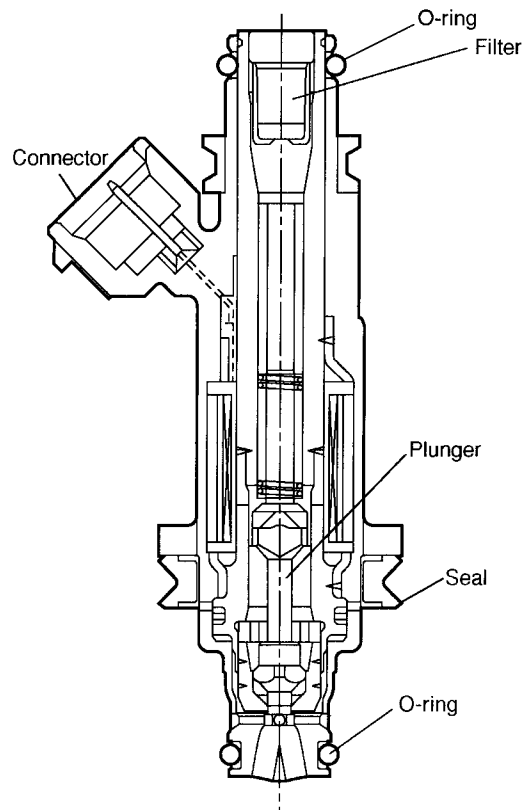

B2H3517C

FUEL LINE

Fuel Injection (Fuel System)

D: FUEL TANK

The fuel tank utilizes a two-compartment design to ensure sufficient capacity without interfering with the rear differential. It is provided with a suction jet pump (included in the fuel pump and fuel level sensor assembly) which transfers fuel from one compartment to the other. Each compartment has an individual fuel level sensor.

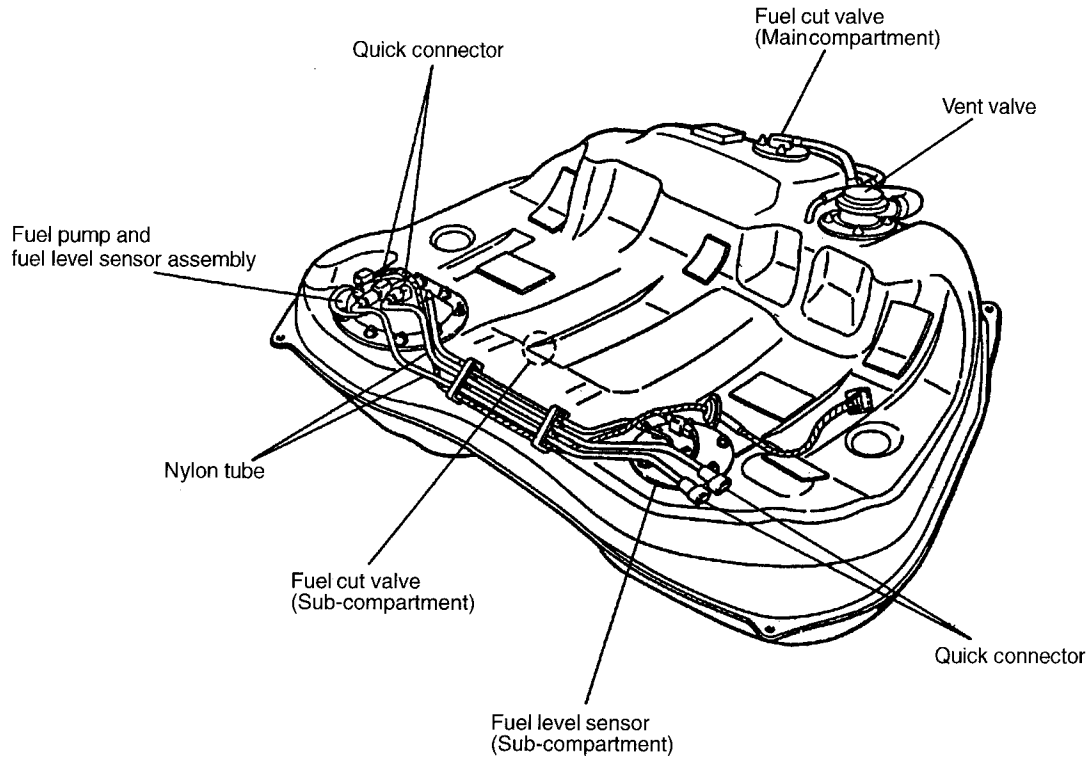

B2H3651B

The fuel tank is located under the rear seat and secured with hold-down bands.

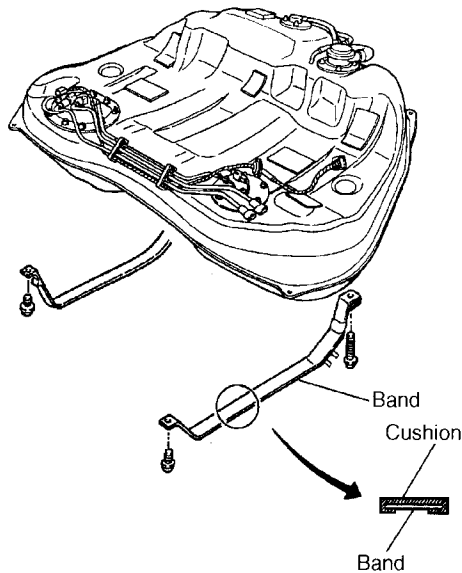

B2H3652A

FU-10

E: FUEL PUMP AND FUEL LEVEL SENSOR ASSEMBLY

1. FUEL PUMP

The fuel pump consists of a motor, impeller, pump casing, pump cover, check valve and filter. It is located in the fuel tank and combined with the fuel level sensor into a single unit. The operation of this impeller type pump is very quiet.

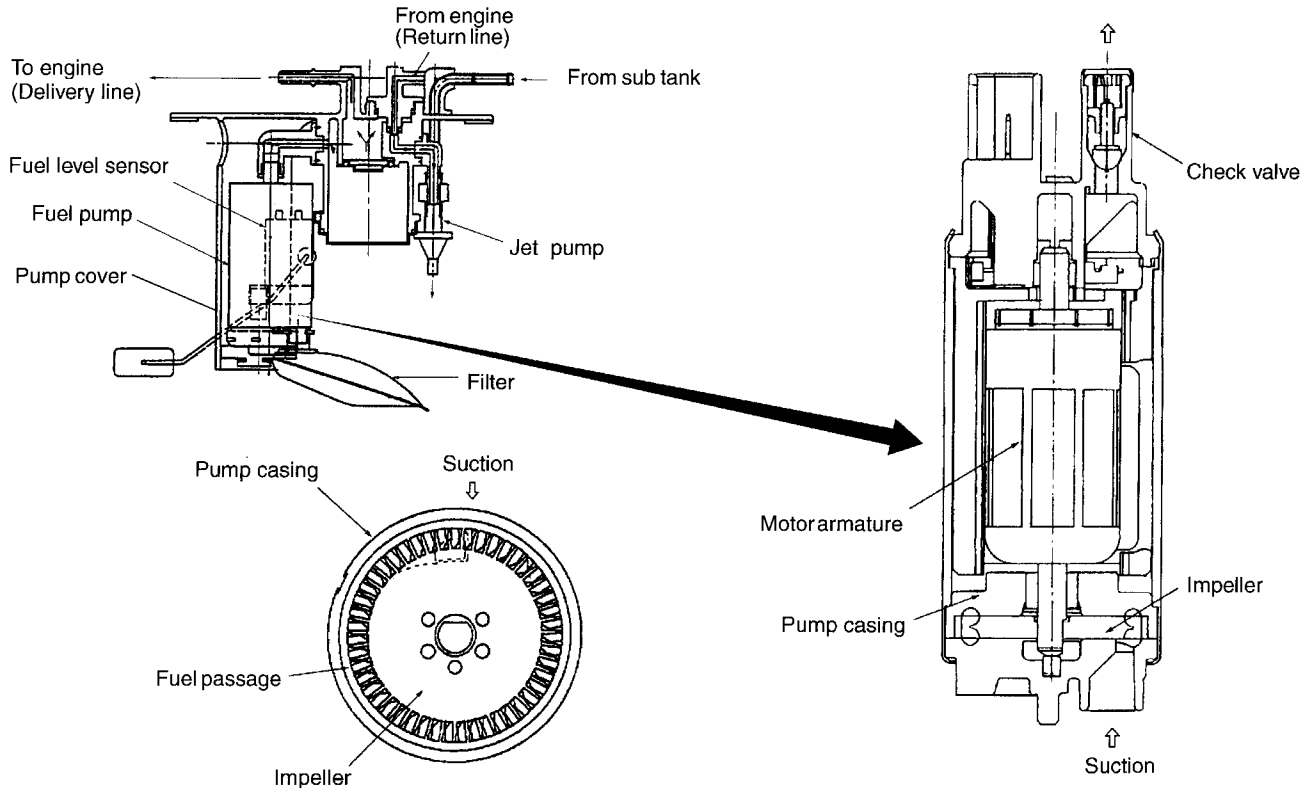

B2H3653B

- When the ignition switch is turned ON, fuel pump relay is activated. Then the motor operates to rotate the impeller.
- As the impeller rotates, fuel in a vane groove of the impeller flows along the fuel passage into the next vane groove by centrifugal force. When fuel flows from one groove to the next, a pressure difference occurs due to friction. This creates a pumping effect.
- The fuel pushed up by rotation of the impeller then passes through the clearance between the armature and the magnet of the motor and is discharged through the check valve.
- When the fuel discharge pressure reaches the specified level, the relief valve opens and excess fuel is released into the fuel tank. In this manner, the relief valve prevents an abnormal increase in fuel pressure.
- When the engine and the fuel pump stop, spring force acts on the check valve to close the discharge port, so that the fuel pressure in the fuel delivery line is retained.

FUEL LINE

Fuel Injection (Fuel System)

2. JET PUMP

- The jet pump utilizes the velocity of fuel returning from the engine to produce negative pressure in it.
- Using the pumping effect produced by the negative pressure, the jet pump transfers fuel from the sub-compartment to the main compartment of the fuel tank.
- When the return line nozzle is clogged, the fuel sent back through the return line flows back into the fuel tank via the relief valve.

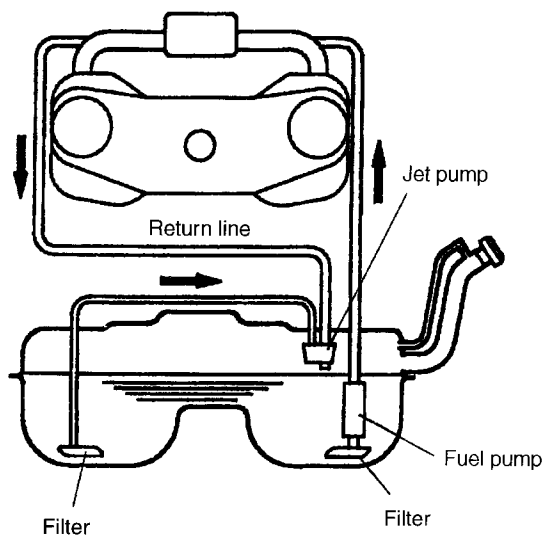
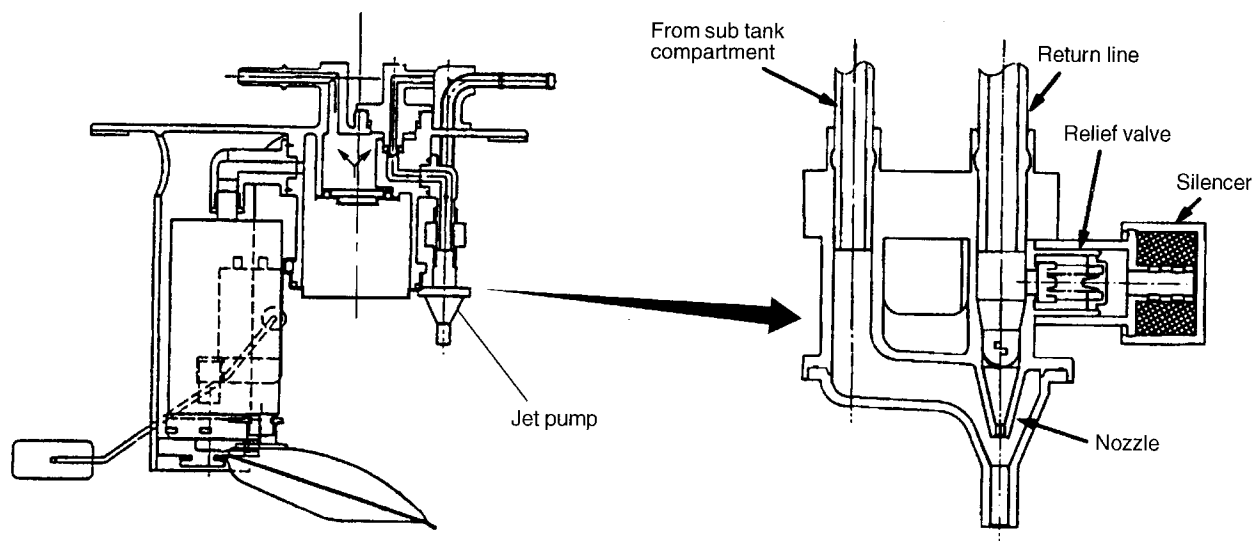

B2H3654B

F: SUB-COMPARTMENT FUEL LEVEL SENSOR

This sensor detects the level of the fuel in the sub-compartment (the compartment in which the fuel pump is not located) and acts as part of the fuel transfer line when the jet pump is in operation to maintain the fuel in both compartments at the same level.

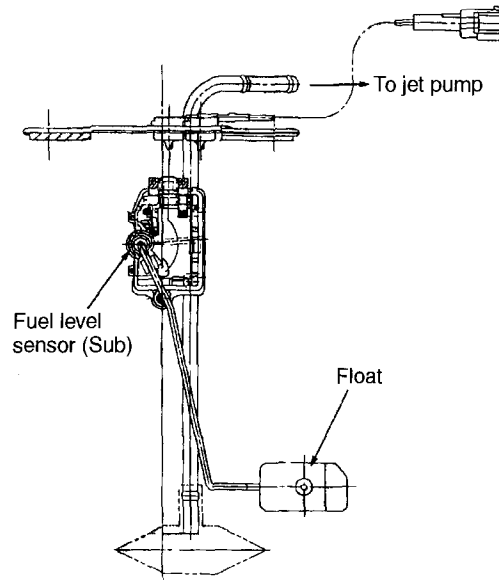

B2H2912A

G: FUEL FILTER

The fuel filter located in the engine compartment is a pressure-withstanding, cartridge type. It has a filter element in a metal case. The fuel entering the filter flows from the perimeter of the element to the center of the filter and goes out from there.

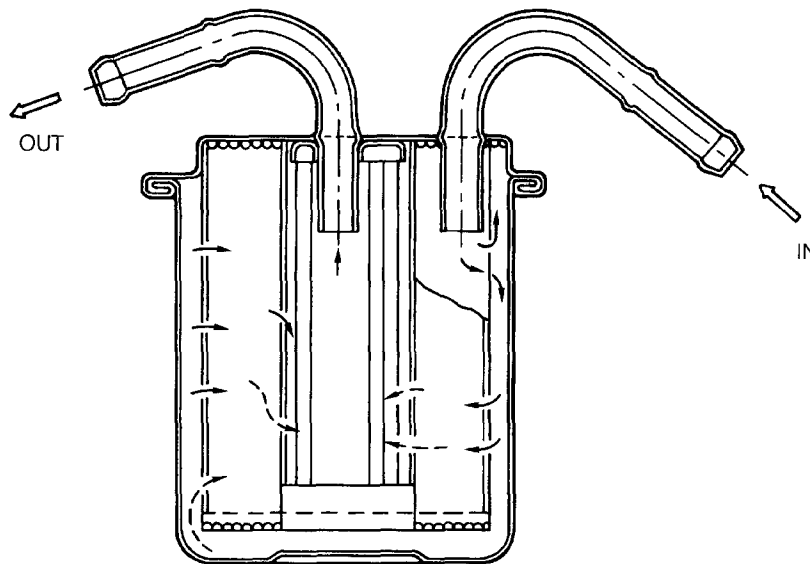

G2H0059