

5. Intake Door Control

The intake door motor is located on the upper part of the intake unit. It opens and closes the intake doors through a rod and a link. When the recirculation switch is pressed (the indicator comes on), the ground circuit of the intake door motor is formed through terminal 2 of the moving contact instead of through terminal 1. This causes the motor to make a rotation to close the intake doors. Since the moving contact is built into the motor and rotates together with it, the ground circuit of the motor opens when the contact's slot reaches terminal 2. The motor then stops.

When the recirculation switch is pressed again (the indicator goes out), the ground circuit is formed through terminal 1 rather than terminal 2. The motor makes a rotation in the same direction as when the switch is first pressed – but now opening the intake doors – until the moving contact's slot reaches terminal 1.

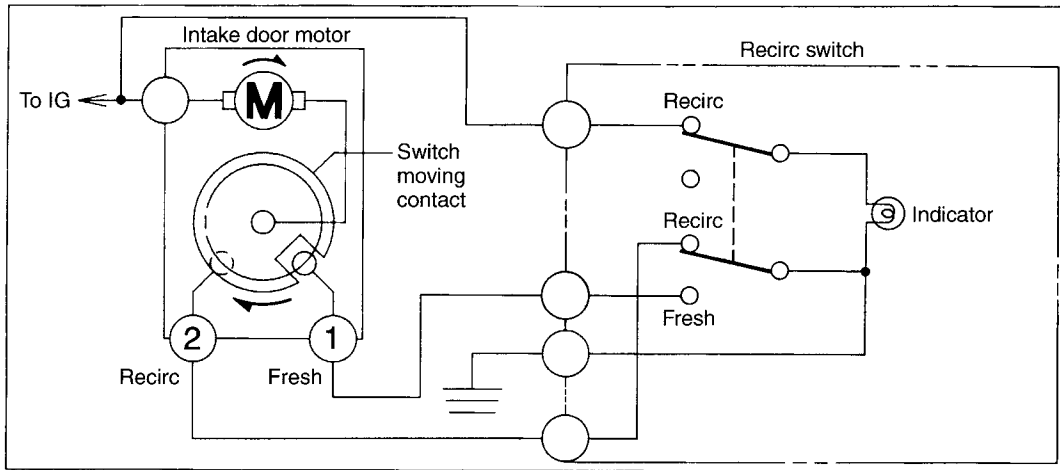

G4H0741A