

COMBINATION METER

Instrumentation/Driver Info

1. Combination Meter

A: WARNING AND INDICATOR LIGHTS

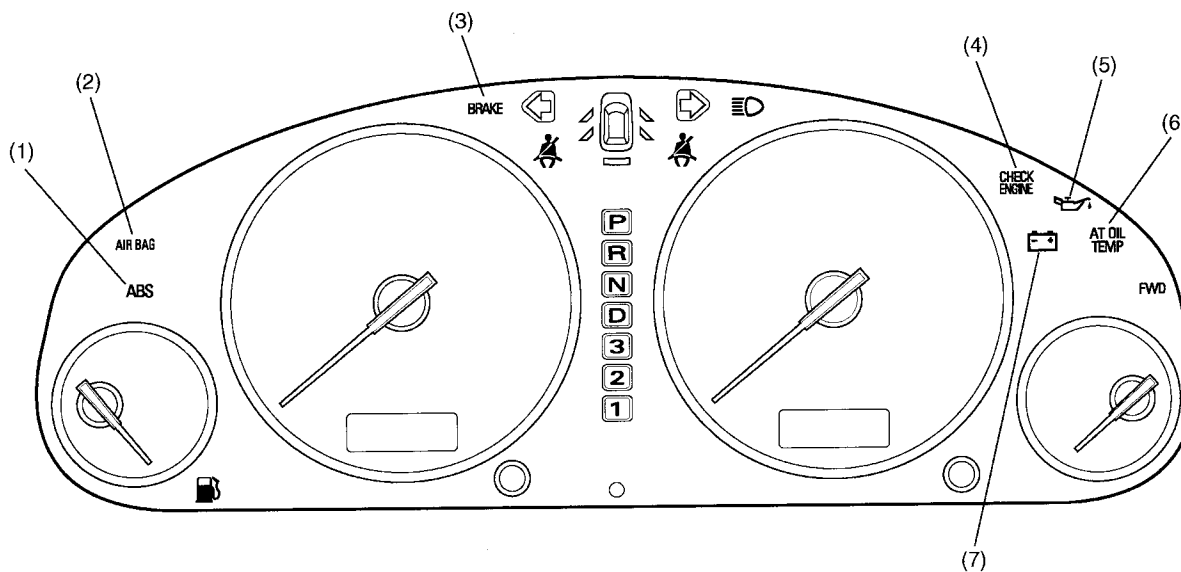

B6H1295A

- (1) **ABS warning light**
This light illuminates when a fault occurs in any electrical component of the ABS (Anti-lock Brake System).
- (2) **AIR BAG system warning light**
This light illuminates when a fault occurs in the airbag system.
- (3) **Brake fluid level warning / parking brake indicator light**
This light illuminates when the fluid level in the brake reservoir tank lowers below the specified level and/or when the parking brake is applied.
- (4) **CHECK ENGINE warning light**
This light illuminates when a fault occurs in the MFI (Multiple point Fuel Injection) system.
- (5) **Oil pressure warning light**
This light illuminates when the engine oil pressure decreases below 14.7 kPa (0.15 kg/cm², 2.1 psi).
- (6) **AT oil temperature warning light**
This light illuminates when the ATF temperature exceeds 150°C (302°F).
- (7) **Charge indicator light**
This light illuminates when a fault occurs in the charging system while the engine is running.

COMBINATION METER

If everything is normal, the warning and indicator lights should be ON or OFF as shown below according to ignition switch positions.

Warning/Indicator light	Ignition switch position			
	LOCK/ACC	ON	ST	While engine is running
(1) ABS	OFF	*3	ON	OFF
(2) AIR BAG	OFF	*2	ON	*2
(3) Brake fluid level / parking brake	OFF	ON	ON	*4
(4) CHECK ENGINE	OFF	*1	ON	OFF
(5) Oil pressure	OFF	ON	ON	OFF
(6) AT oil temperature	OFF	ON	ON	OFF
(7) Charge	OFF	ON	ON	OFF

*1: This light comes ON before engine starts, and stays OFF after engine has started.

*2: This light comes ON for about 7 seconds, and then goes out.

*3: This light comes ON for about 2 seconds, and then goes out.

*4: This light comes ON when the parking brake is applied.

COMBINATION METER

Instrumentation/Driver Info

B: TELLTALE (GRAPHIC MONITOR)

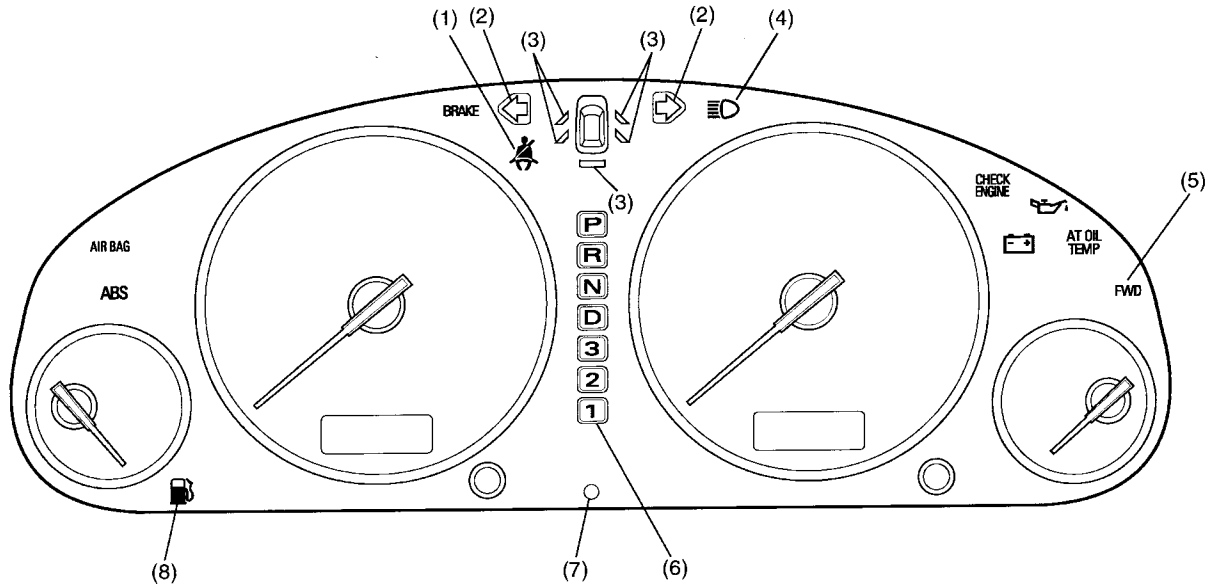

B6H1295B

- (1) Seat belt warning light
This light stays illuminated for about 6 seconds after the ignition switch has been turned ON if the driver's seat belt is not fastened.
- (2) Turn signal indicator light
This light blinks in unison with the corresponding turn signal lights when the turn signal switch is operated.
- (3) Door open warning light
This light illuminates when one or more doors, rear gate and/or trunk lid are not completely closed.
- (4) Headlight beam indicator light
This light illuminates when the headlights are in the high-beam position.
- (5) FWD indicator light
This light illuminates when the center differential locks (with the fuse installed in the center differential locking circuit).
- (6) AT selector lever position indicator
The light corresponding to the present AT select lever position illuminates when the ignition switch is in any position other than ACC and LOCK.
- (7) Security indicator light
This light illuminates when the security system is armed.
- (8) Low fuel warning light
This light illuminates when the quantity of the fuel remaining in the tank has decreased to 10 liters (2.6 US gal, 2.2 Imp gal) or smaller.

COMBINATION METER

Instrumentation/Driver Info

If everything is normal, the telltales should be ON, OFF or in other states as shown below according to ignition switch positions.

Telltale light		Ignition switch position			
		LOCK/ACC	ON	ST	While engine is running
(1) Seat belt		OFF	*2	*2	*2
(2) Turn signal		OFF	Blink	Blink	Blink
(3) Door, rear gate or trunk lid open	● Open	ON	ON	ON	ON
	● Shut	OFF	OFF	OFF	OFF
(4) Headlight beam	● High beam	OFF	ON	ON	ON
	● Low beam	OFF	OFF	OFF	OFF
(5) FWD	● FWD	OFF	ON	ON	ON
	● AWD	OFF	OFF	OFF	OFF
(6) AT selector lever position		OFF	ON	ON	ON
(7) Security		*3	OFF	OFF	OFF
(8) Low fuel		OFF	*1	*1	*1

*1: This light illuminates when quantity of the fuel remaining in the tank has decreased to 10 liters (2.6 US gal, 2.2 Imp gal) or smaller.

*2: This light illuminated for about 6 seconds after the ignition switch has been turned ON if the driver's seat belt is NOT fastened.

*3: This light blinks when the security system is armed.

COMBINATION METER

Instrumentation/Driver Info

C: SPEEDOMETER

1. DESCRIPTION

- The speedometer system is an electrical type that uses electric signals from the speed sensor in the MT model or the transmission control module (TCM) in the AT model.
- The vehicle speed sensor is installed on the manual transmission.
- Since the system does not use mechanical components such as rotating cable, there are no opportunities of occurring such problems as meter needle vibration and cable disconnection. Also, it does not constitute any means of mechanical noise transmission.
- The odometer and tripmeter readings appear on a liquid crystal display (LCD).

2. OPERATION

MT model: The vehicle speed sensor sends vehicle speed signals (4 pulses per rotation of speed sensor's driven shaft) to the speedometer drive circuit and odometer/tripmeter drive circuit in the speedometer.

AT model: The TCM sends vehicle speed signals (4 pulses per rotation of output shaft) to the speedometer drive circuit and odometer/tripmeter drive circuit in the speedometer.

NOTE:

Signals from the speed sensor or TCM are also used by the engine control module, automatic transmission control module, etc.

3. SPECIFICATION

Speedometer	Type	Electric pulse type.
	Indication	Needle points to 60 km/h (37.3 miles) when 2,548 pulses are input per minute.
Odometer	Type	Pulse count type.
	Display	LCD/6 digits; 0 to 999,999 km (mile).
	Indication	Counts up 1 km per 2,548 pulses (1 mile per 4,104 pulses). (Count down is impossible.)
Tripmeter	Type	Pulse count type.
	Display	LCD/4 digits; 0 to 999.9 km (mile).
	Indication	Counts up 1 km per 2,548 pulses (1 mile per 4,104 pulses). (Push knob is adopted to return the tripmeter to zero indication.)

4. SYSTEM DIAGRAM

MT model

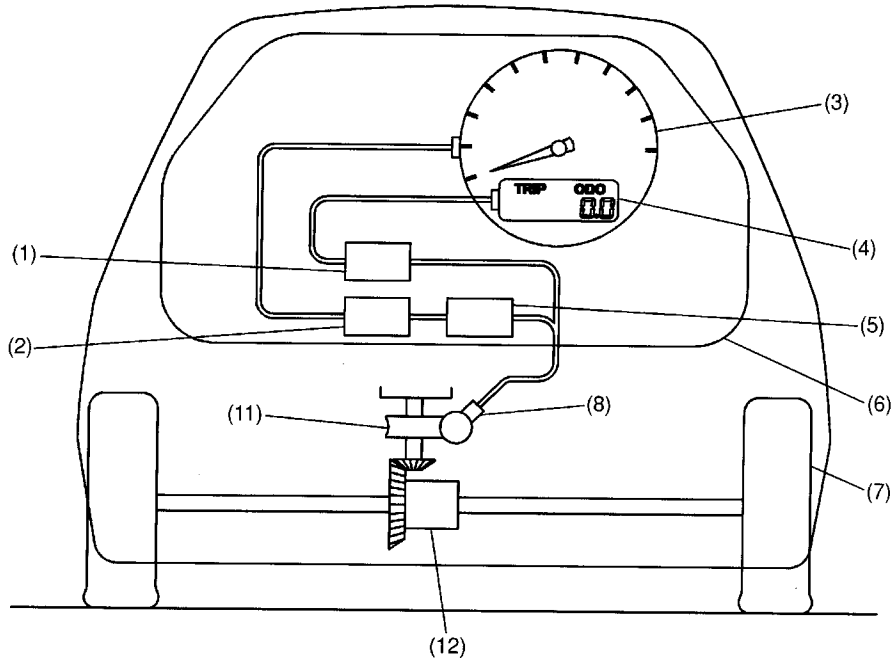

AT model

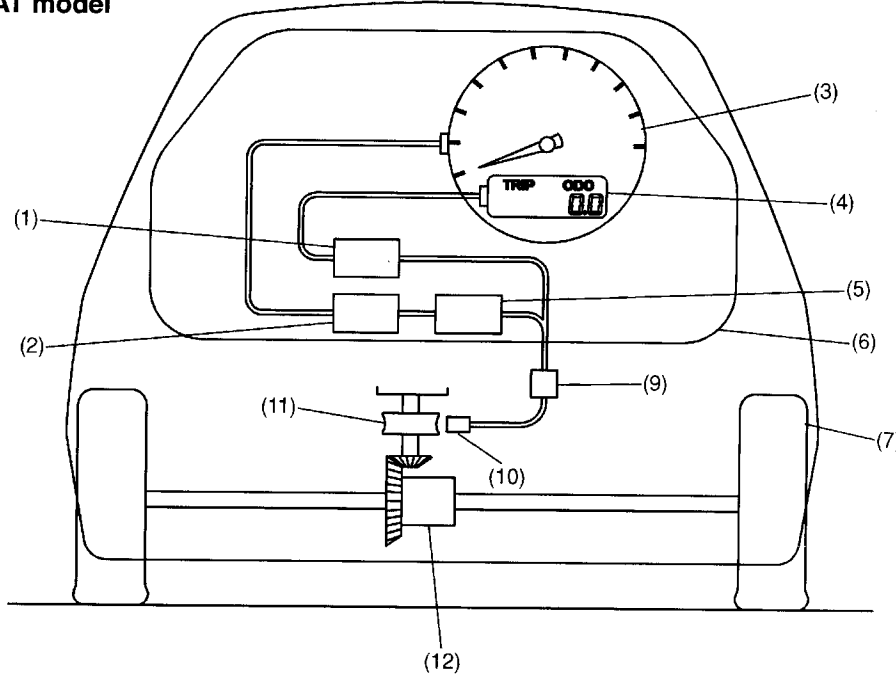

- (1) Odometer/tripmeter drive circuit
- (2) Speedometer movement
- (3) Speedometer
- (4) Odometer/tripmeter
- (5) Speedometer drive circuit
- (6) Combination meter

- (7) Front wheel
- (8) Speed sensor
- (9) TCM
- (10) Electromagnetic pick-up
- (11) Gear for the speed sensor
- (12) Differential

B6H1167B

COMBINATION METER

Instrumentation/Driver Info

D: VEHICLE SPEED SENSOR

The vehicle speed sensor uses a Hall IC pick-up to generate speed signals. (MT model)

This sensor is installed on the transmission case and detects rotating speed of the transmission output gear.

The sensor generates 4 pulses per rotation of the speed sensor driven shaft and send them to the speedometer.

1. CONSTRUCTION

The speed sensor mainly consists of a Hall IC, magnet ring, driven shaft and spring.

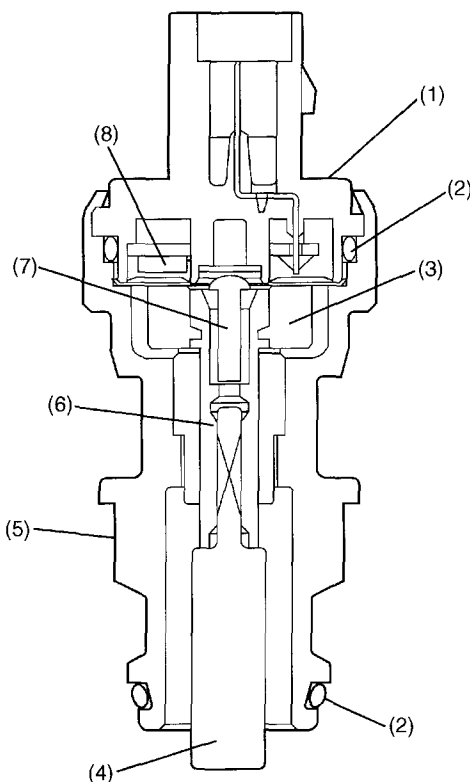

B6H0911B

- (1) Upper case
- (2) O-ring
- (3) Magnet ring

- (4) Driven key
- (5) Lower case
- (6) Driven shaft

- (7) Rivet
- (8) Hall IC

2. OPERATION

As the driven key rotates, the magnet turns causing the magnetic field of the Hall IC to change. The Hall IC generates a signal that corresponds to a change in the magnetic field.

One turn of the driven key in the speed sensor sends 4 pulses to the combination meter, engine control module and cruise control module.

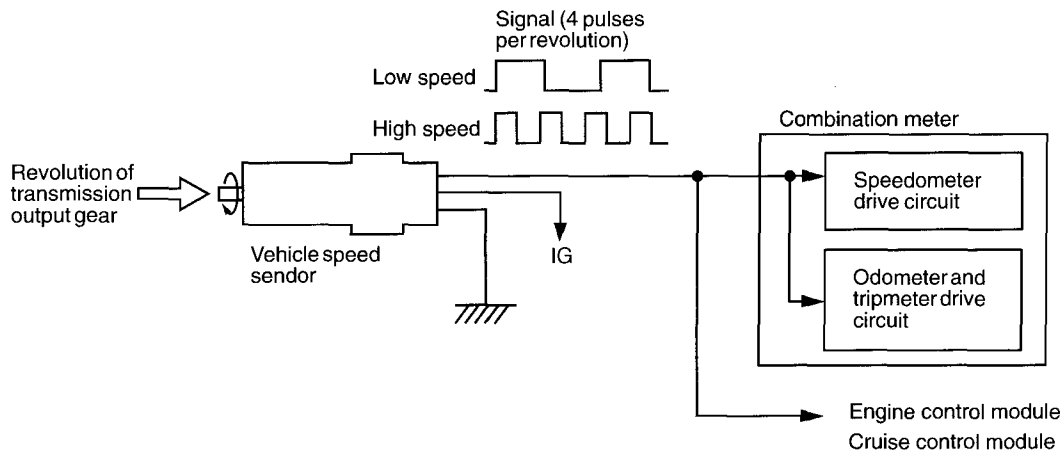

B6H0912D

E: TACHOMETER

The tachometer drive circuit is connected to the engine speed sensing circuit in the engine control module.

When the engine speed increases or decreases, the voltage of the circuit also increases or decreases, changing the magnetic force of the tachometer drive coil.

The tachometer needle then moves in accordance with change in the engine speed.

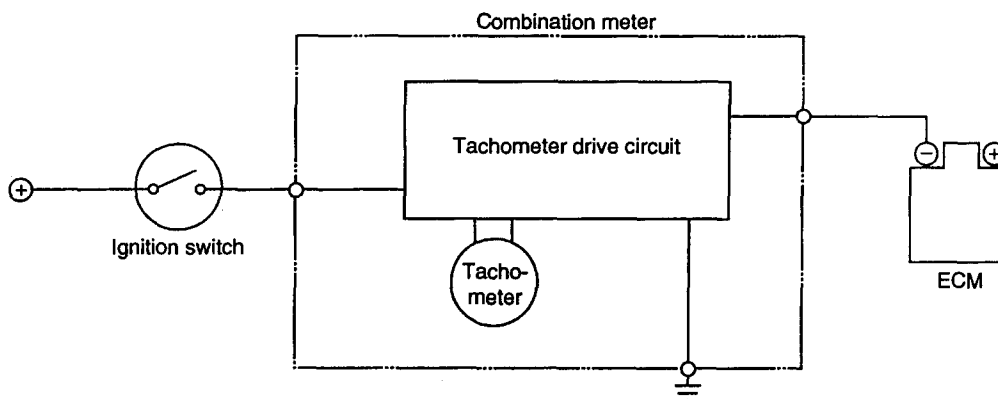

H6H0419

COMBINATION METER

Instrumentation/Driver Info

F: WATER TEMPERATURE GAUGE

- The water temperature gauge is a cross-coil type.
- The water temperature signal is sent from the thermo gauge located on the engine.
- The resistance of the thermo gauge changes according to the engine coolant temperature. Therefore, the current sent to the water temperature gauge also changes according to the engine coolant temperature. As the change in current causes the magnetic force of the coil to change, the gauge's needle moves according to the engine coolant temperature.
- When the coolant is at a normal operating temperature of approx. 70 to 100 °C (158 to 212 °F), the gauge's needle stays in the middle of the indication range as shown below.

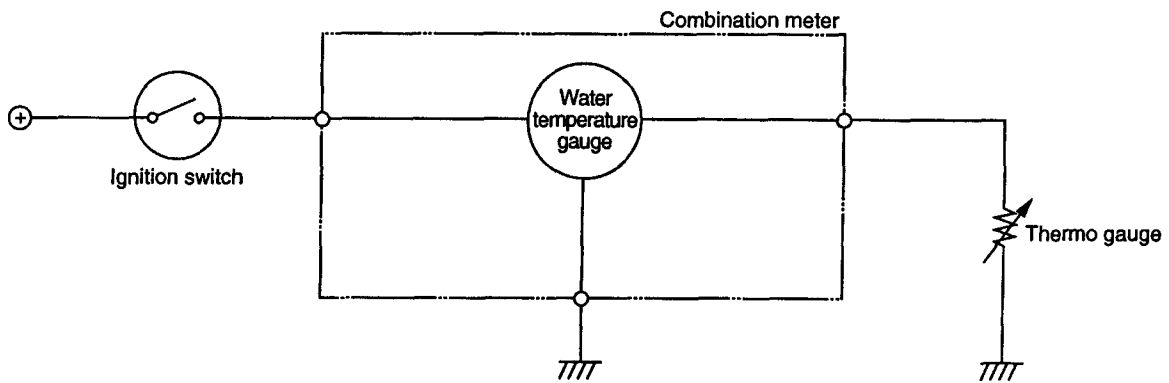
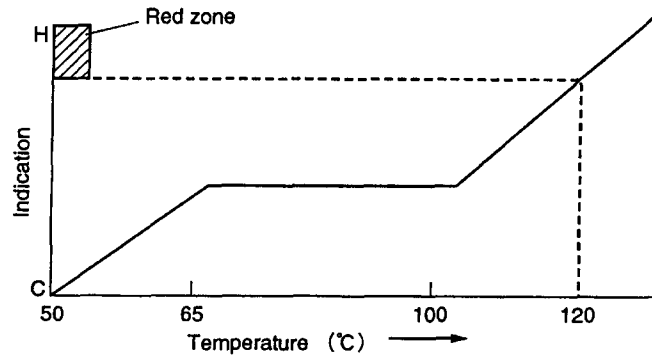

H6H0420

G: FUEL GAUGE

1. GENERAL

- The fuel gauge unit consists of a float and a potentiometer whose resistance varies depending on movement of the float. It is located inside the fuel tank and forms an integral part of the fuel pump. The fuel gauge indicates the fuel level in the tank even when the ignition switch is in the LOCK position.
- All models are equipped with two fuel level sensors. These sensors are installed in the fuel tank, one on the right side and the other on the left side. Two sensors are necessary because the fuel tank is divided into main and sub tank compartments.
- The low fuel warning light switch is incorporated in the main fuel level sensor.

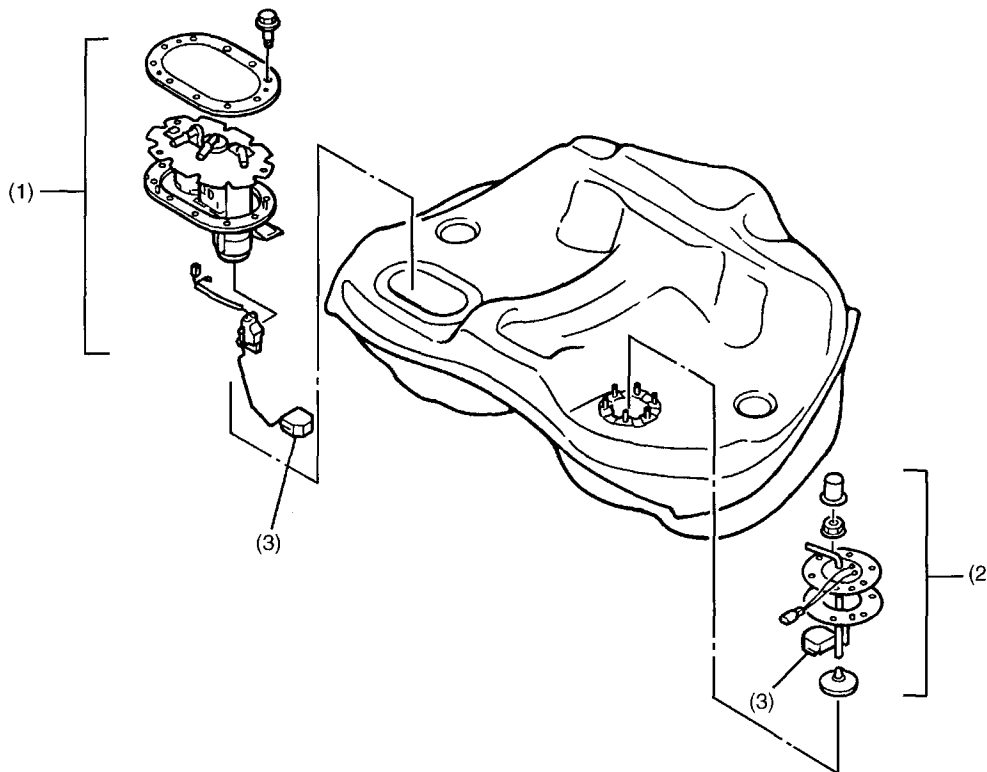

- (1) Main fuel level sensor
- (2) Sub fuel level sensor
- (3) Float

B6H1296A

COMBINATION METER

Instrumentation/Driver Info

Main fuel level sensor

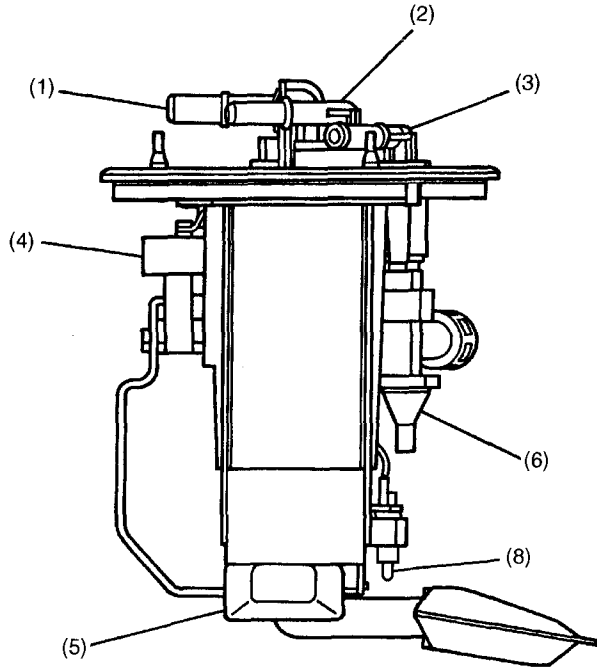

- (1) To engine
- (2) From engine
- (3) From sub tank compartment
- (4) Level sensor

Sub fuel level sensor

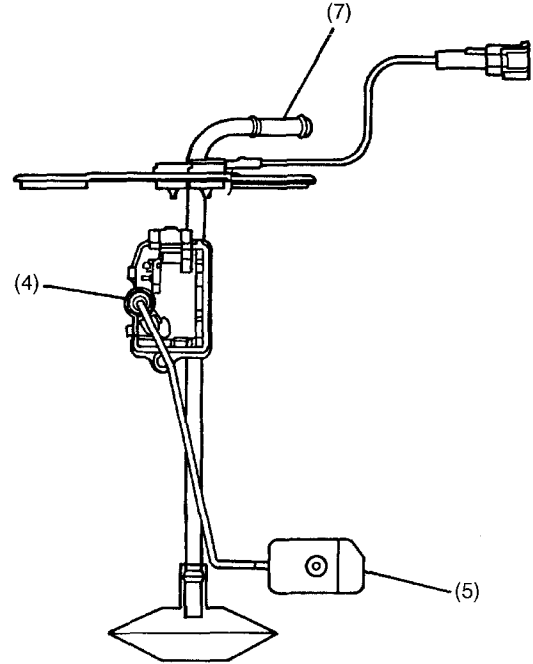

- (5) Float
- (6) Jet pump
- (7) To jet pump
- (8) Gas sensor

B6H1297A

2. OPERATION

The low fuel warning light operates as follows:

The ECM continually monitors the resistance signal from the fuel level sensor. It turns on the low fuel warning light in the combination meter if a resistance value corresponding to the critical fuel level (approx. 76 Ω) is detected successively for about 10 minutes or the period spent for driving a distance of 10 km.

This monitoring time has been decided to avoid false operation of the warning light which may happen when a large part of remaining fuel is collected temporarily in the sub tank compartment.

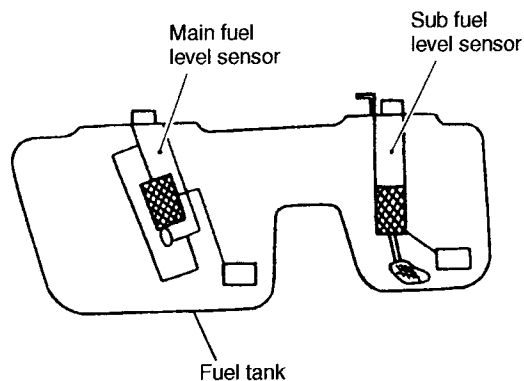

B6H0026B

3. SPECIFICATIONS

	Fuel amount	Resistance
Main fuel level sensor	FULL	0.5–2.5 Ω
	1/2	18.5–22.5 Ω
	EMPTY	52.5–54.5 Ω
Sub fuel level sensor	FULL	0.5–2.5 Ω
	1/2	23.6–27.6 Ω
	EMPTY	39.5–41.5 Ω

COMBINATION METER

Instrumentation/Driver Info

4. CIRCUIT DIAGRAM

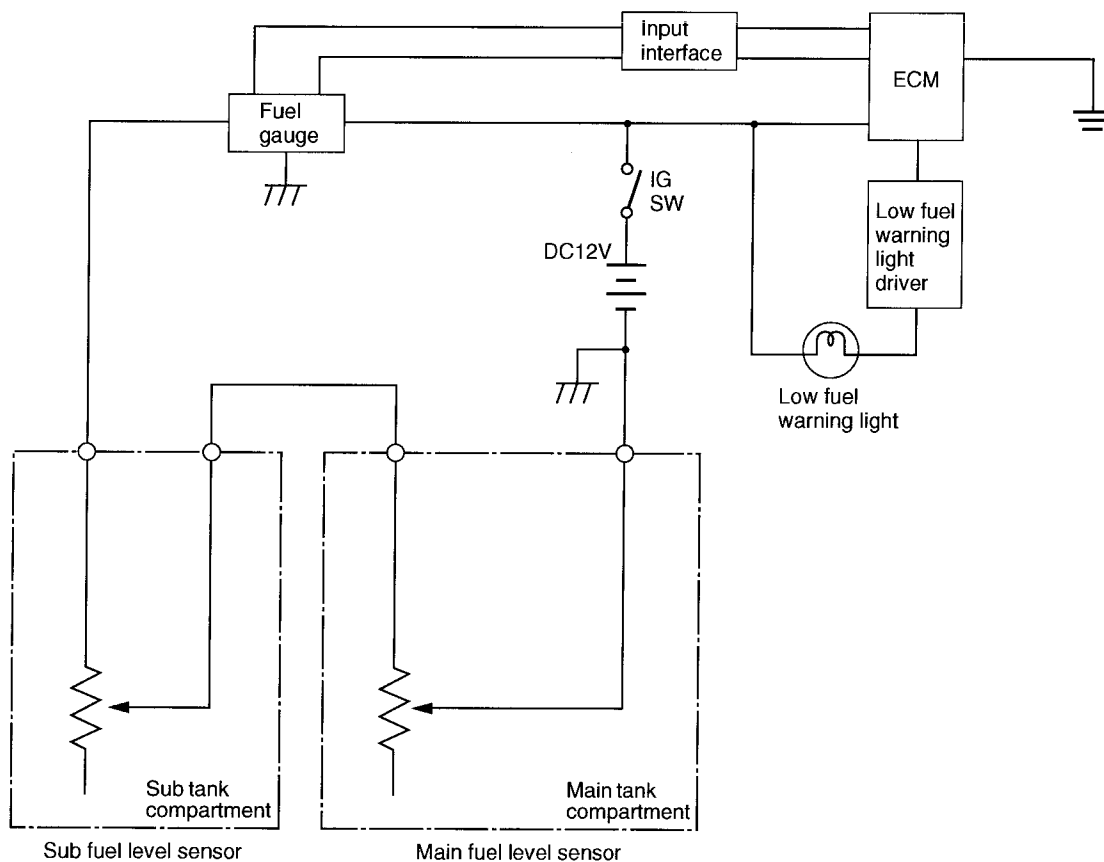

B6H1281B