

1. General

The H4 engine is of a horizontally opposed, four-cylinder design. This four-stroke-cycle, water-cooled, SOHC engine uses a total of 16 valves and its main components are made of aluminum alloy. It is fueled by a multiple fuel injection system.

The engine's major structural and functional features are as follows:

- The cylinder head forms pentroof combustion chambers, each having a spark plug located at its center and two each of intake and exhaust valves (four valves per cylinder). The intake and exhaust ports are located in a cross-flow arrangement.
- There are a screw and nut at the valve end of each rocker arm. They are used for adjusting the valve clearance.
- A single timing belt drives two camshafts on the left and right banks and the engine coolant pump on the left bank. Belt tension is automatically adjusted by a belt tension adjuster, eliminating need for a manual adjustment.
- The crankshaft is supported by five bearings with high rigidity and strength.
- The cylinder block is an aluminum die casting fitted with iron die-cast cylinder liners.

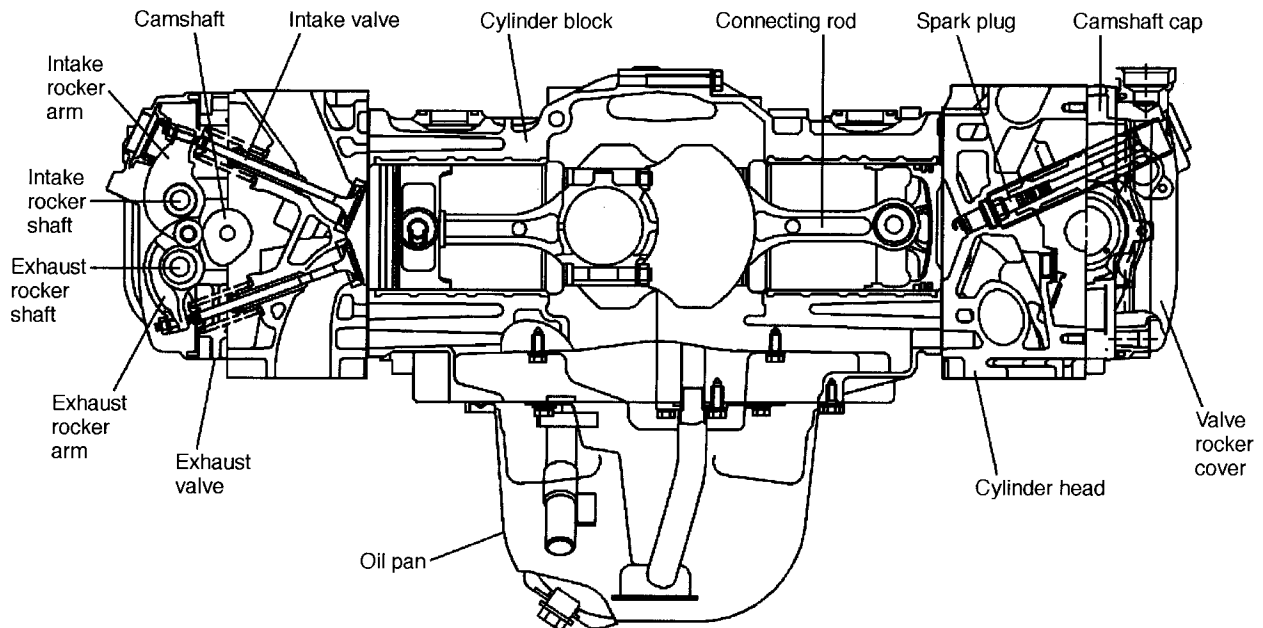

B2H1983A