

2. Timing Belt

- A single timing belt drives two camshafts (one in the left bank and one in the right bank). The belt also drives the water pump by its non-toothed side.
- The timing belt teeth have a specially designed round profile which contributes to quiet operation. The timing belt is made of strong and inflexible core cords, wear-resistant canvas and heat-resistant rubber material.
- A hydraulic automatic belt tension adjuster always keeps the belt taut to the specified tension. Any manual belt tension adjustment is unnecessary.

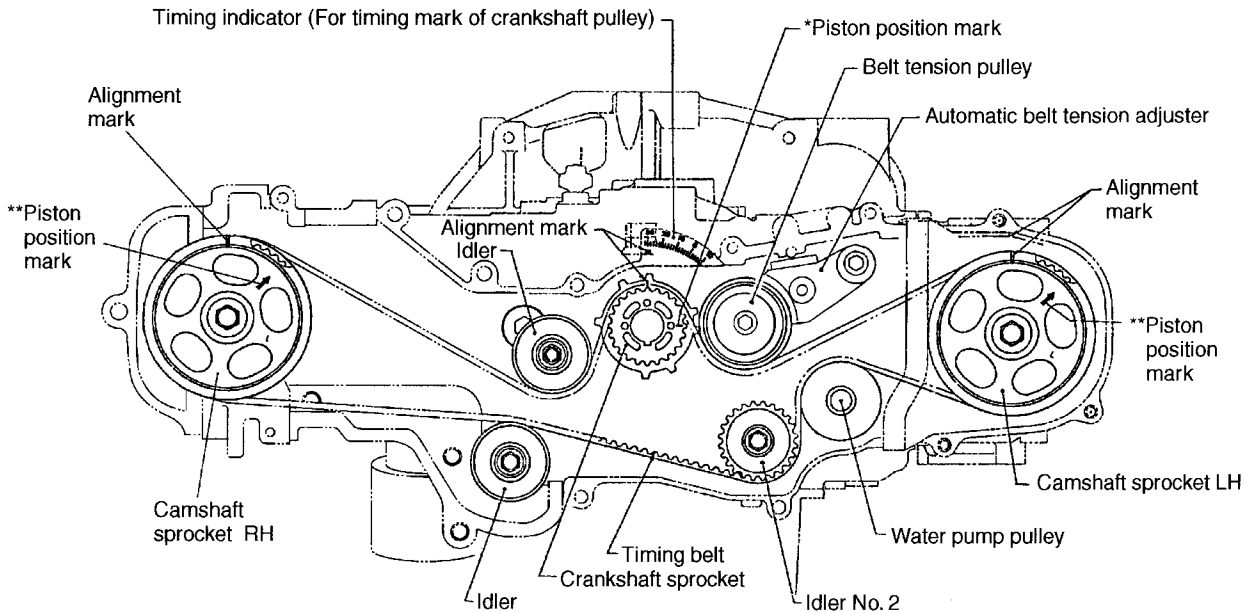

B2H3410B

NOTE:

*: The #1 piston is at TDC when the piston position mark on the crankshaft sprocket is aligned with the timing mark on the cylinder block.

** : The #1 piston is at TDC on the compression stroke when the piston position mark on the camshaft sprocket is aligned with the timing mark on the belt cover.