

## 2. Timing Chains

- Two timing chains are used to drive the camshafts, one each for driving the two camshafts on each bank. Every camshaft is fitted with a sprocket through which it is driven by the corresponding timing chain. The left bank timing chain transmits the power from the crankshaft sprocket directly to the left bank camshaft sprockets, whereas the right bank timing chain transmits the crankshaft power via the lower idler sprocket which is driven by the left bank timing chain. (The lower idler gear has two tooth rows; the left bank timing chain engages with the inner row teeth and the right bank chain engages with the outer row teeth.) By this way, the right and left bank camshafts rotate in synchronization with each other.

The left bank timing chain also drives the water pump.

- The hydromechanical automatic chain tension adjuster provided for each chain constantly maintains the specified chain tension necessary to properly drive the camshafts, as well as to provide this chain and sprocket camshaft drive mechanism with a "maintenance-free" feature.

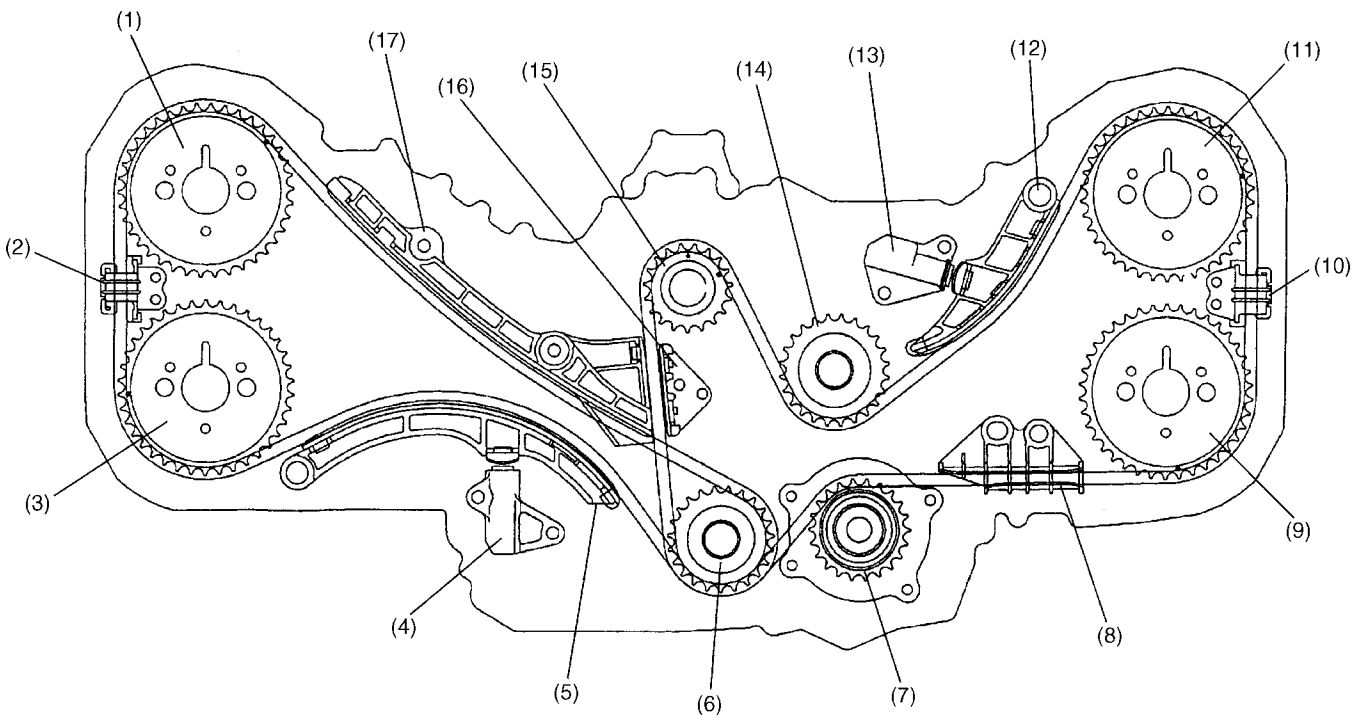

B2H3895A

- |                                     |                                  |                           |
|-------------------------------------|----------------------------------|---------------------------|
| (1) Intake camshaft sprocket RH     | (7) Water pump sprocket          | (13) Tension adjuster LH  |
| (2) Chain guide RH No.1             | (8) Chain guide LH No.2          | (14) Upper idler sprocket |
| (3) Exhaust camshaft sprocket RH    | (9) Exhaust camshaft sprocket LH | (15) Crankshaft sprocket  |
| (4) Chain tension adjuster RH       | (10) Chain guide LH No.1         | (16) Center chain guide   |
| (5) Chain tension adjuster lever RH | (11) Intake camshaft sprocket LH | (17) Chain guide RH No.2  |
| (6) Lower idler sprocket            | (12) Tension adjuster lever LH   |                           |