

2. Power Steering System

A: HYDRAULIC SYSTEM

- The fluid pump is directly driven by the engine through a belt.
- When the steering wheel is not being turned, the pressure-sensitive valve in the pump opens to drain the fluid into the fluid reservoir tank.
- The fluid pressure is maintained almost constant regardless of change in the engine speed by the function of the flow control valve. The pressure-regulated fluid is delivered to the control valve via hose A.
- When the steering wheel is turned, the rotary control valve connected to the pinion shaft opens the hydraulic circuit corresponding to the direction in which the steering wheel is turned. The fluid then flows into chamber A or B via pipe A or B.
- The fluid pressure in chamber A or B acts on the rack piston in the same direction as that in which the rack shaft is moved by rotation of the steering wheel. This helps reduce the effort required of the driver to operate the steering wheel.
- Movement of the rack piston causes the fluid in the other chamber to return to the reservoir tank via pipe A or B, control valve, and hose B.
 - As the steering shaft is connected to the pinion shaft mechanically via the rotary control valve, the steering system can operate as a manual system even if the hydraulic system becomes in-operative.
 - To control the maximum fluid pressure, a relief valve is built into the fluid pump to prevent build-up of an excessive fluid pressure.

POWER STEERING SYSTEM

Power Assisted System (Power Steering)

2.5ℓ MODEL

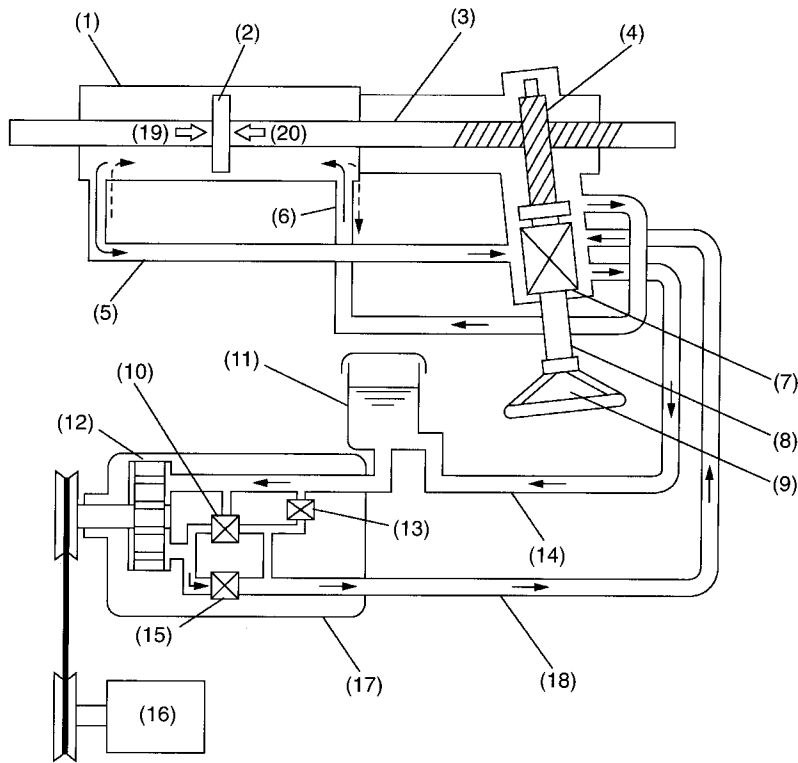

B4H1719B

- | | | |
|--------------------------|-------------------------------|-------------------------|
| (1) Power cylinder | (8) Steering shaft | (15) Flow control valve |
| (2) Rack piston | (9) Steering wheel | (16) Engine |
| (3) Rack shaft | (10) Pressure-sensitive valve | (17) Fluid pump |
| (4) Piston shaft | (11) Tank | (18) Hose A |
| (5) Pipe A | (12) Vane pump | (19) Chamber A |
| (6) Pipe B | (13) Relief valve | (20) Chamber B |
| (7) Rotary control valve | (14) Hose B | |

POWER STEERING SYSTEM

Power Assisted System (Power Steering)

3.0ℓ MODEL

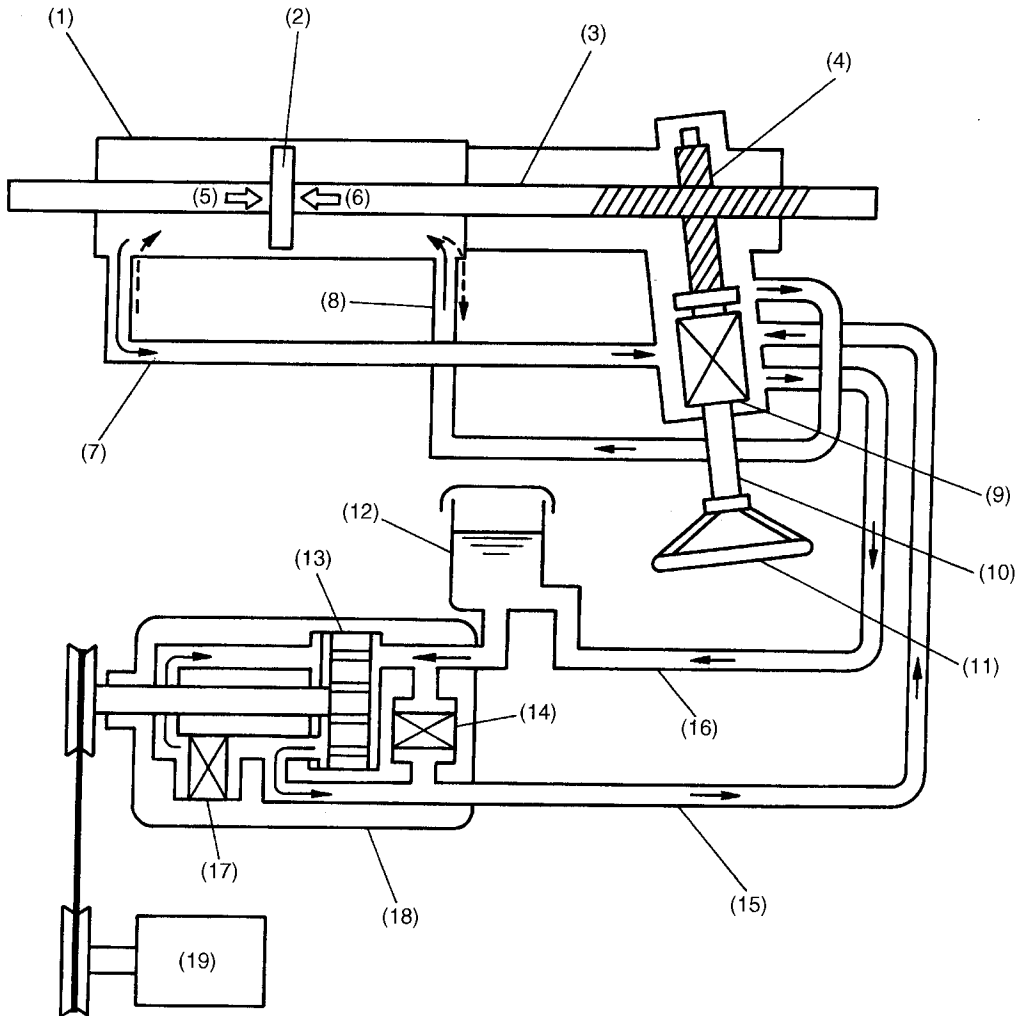

S4H0023B

- | | |
|---------------------|-------------------------|
| (1) Power cylinder | (11) Steering wheel |
| (2) Rack piston | (12) Tank |
| (3) Rack shaft | (13) Vane pump |
| (4) Pinion shaft | (14) Relief valve |
| (5) Chamber A | (15) Hose A |
| (6) Chamber B | (16) Hose B |
| (7) Pipe A | (17) Pump control valve |
| (8) Pipe B | (18) Fluid pump |
| (9) Control valve | (19) Engine |
| (10) Steering shaft | |

POWER STEERING SYSTEM

Power Assisted System (Power Steering)

B: GEARBOX ASSEMBLY

1. POWER CYLINDER

The gearbox integrates the control valve and power cylinder into a single unit. The rack shaft serves as a power cylinder piston. The rotary control valve is located around the pinion shaft.

The rotary control valve and power cylinder are connected to each other by two pipes through which hydraulic fluid flows.

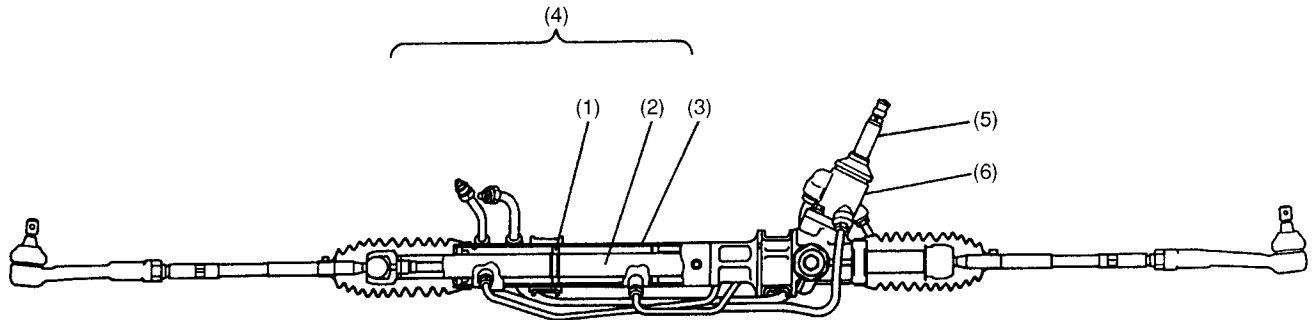

S4H0024A

- (1) Piston
- (2) Rack shaft
- (3) Cylinder

- (4) Power cylinder
- (5) Pinion shaft
- (6) Control valve

POWER STEERING SYSTEM

Power Assisted System (Power Steering)

2. ROTARY CONTROL VALVE

The rotary control valve consists of a rotor (which rotates together with the steering shaft), a pinion (which is connected to the rotor and torsion bar), and a sleeve (which rotates together with the pinion). The rotor and sleeve have grooves C and D, respectively, which form fluid passages V_1 through V_4 .

The pinion is in mesh with the rotor with adequate clearance, which enable the rack to be moved manually by rotating the steering shaft (fail-safe feature).

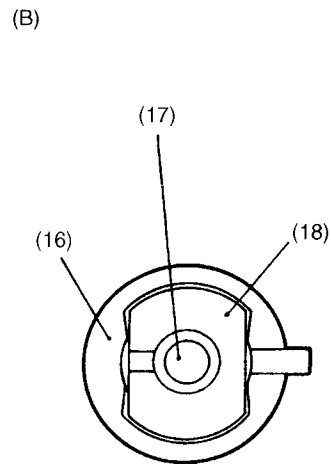
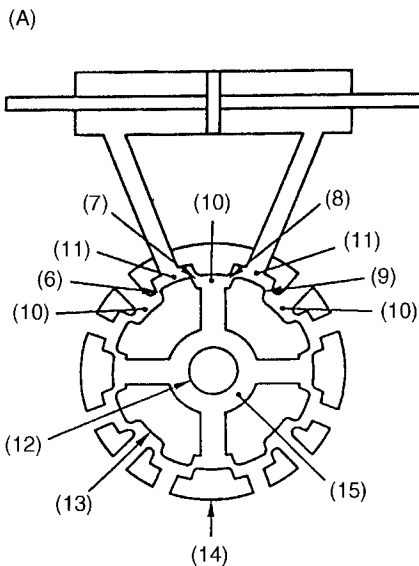
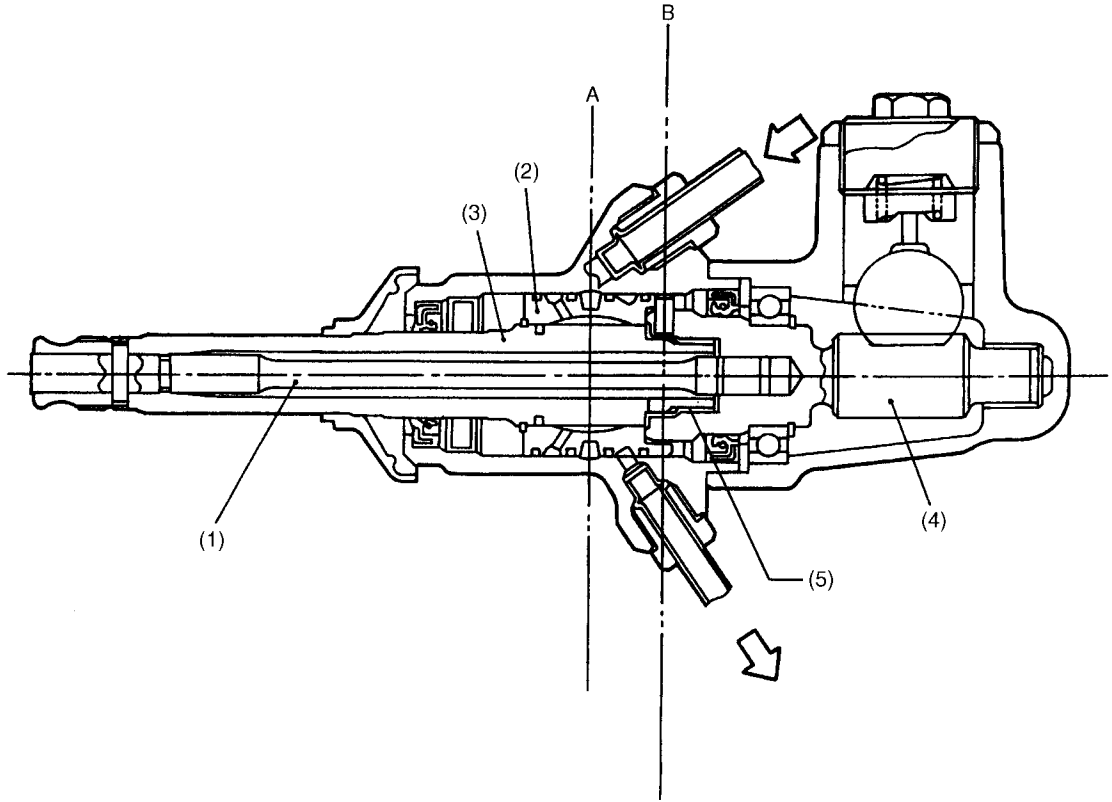

S4H0025C

POWER STEERING SYSTEM

Power Assisted System (Power Steering)

- (1) Torsion bar
- (2) Sleeve
- (3) Rotor
- (4) Pinion
- (5) Pinion-to-rotor engagement (fail-safe feature)
- (6) Fluid passage V_1
- (7) Fluid passage V_2
- (8) Fluid passage V_3
- (9) Fluid passage V_4
- (10) Groove C
- (11) Groove D
- (12) Torsion bar
- (13) Rotor
- (14) Sleeve
- (15) Fluid return line (to reservoir tank)
- (16) Pinion
- (17) Torsion bar
- (18) Rotor
- (A) Cross-sectional view A (fluid passage switching circuit)
- (B) Cross-sectional view B (pinion-to-rotor engagement)

POWER STEERING SYSTEM

Power Assisted System (Power Steering)

- Principle of operation

When the torsion bar is twisted by a rotational force applied to the steering wheel, the relative position between the rotor and sleeve changes. This changes the cross-sectional area of fluid passages V_1 , V_2 , V_3 and V_4 . The fluid passages are thus switched and the fluid pressure is controlled in accordance with the operation of the steering wheel.

- When no steering force is applied:

The rotor and sleeve are held at the neutral position. Fluid passages V_1 , V_2 and V_3 , which are formed by grooves C and D are open equally. Under this condition, the fluid from the pump returns to the reservoir tank so that neither fluid pressure builds up nor the rack piston moves in the power cylinder.

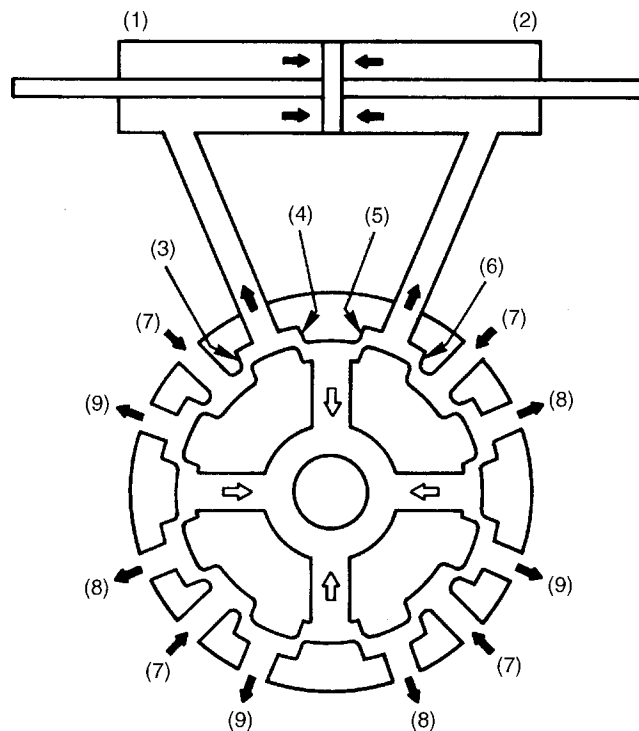

- (1) Chamber A
- (2) Chamber B
- (3) V_1

- (4) V_2
- (5) V_3
- (6) V_4

- (7) From fluid pump
- (8) To A
- (9) To B

S4H0334A

POWER STEERING SYSTEM

Power Assisted System (Power Steering)

- When steering force is applied:

When the steering wheel is turned to the right, for example, fluid passages V_1 and V_3 are opened while fluid passages V_2 and V_4 are nearly closed.

At this point, the fluid pressure in chamber A of the power cylinder increases depending on the degree of closure of fluid passages V_2 and V_4 so that the rack piston moves to the right. The fluid in chamber B, on the other hand, is drained through fluid passage V_3 into the reservoir tank.

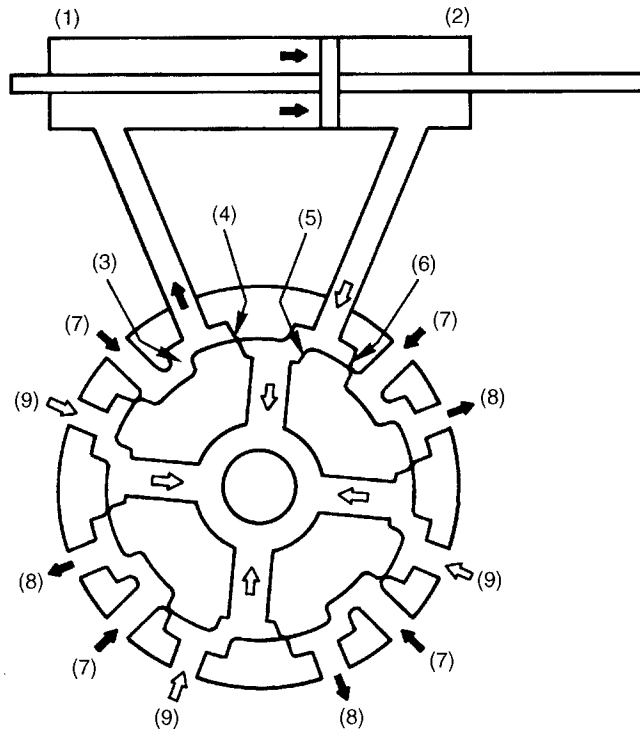

S4H0336A

- (1) Chamber A
- (2) Chamber B
- (3) V_1

- (4) V_2
- (5) V_3
- (6) V_4

- (7) From fluid pump
- (8) To A
- (9) From B

- Fail-safe feature

If fluid pressure fails to build up due to, for example, a broken fluid pump drive belt, the steering wheel rotating torque is transmitted from the valve rotor to the pinion through mechanical engagement between them.

POWER STEERING SYSTEM

Power Assisted System (Power Steering)

C: FLUID PUMP AND RESERVOIR TANK

1. 2.5ℓ MODEL

The fluid pump is a vane type driven by the engine via belt.

The reservoir tank is mounted on the vehicle body.

The fluid pump incorporates the flow control valve, pressure-sensitive valve, and relief valve, each performing the following functions:

- The flow control valve regulates the flow rate of discharged fluid to a constant level irrespective of the engine speed.
- The pressure-sensitive valve returns the fluid to the reservoir tank when there is no steering input.
- The relief valve protects the system from an excessively high pressure which may occur, for example, when the steering wheel is turned all the way.

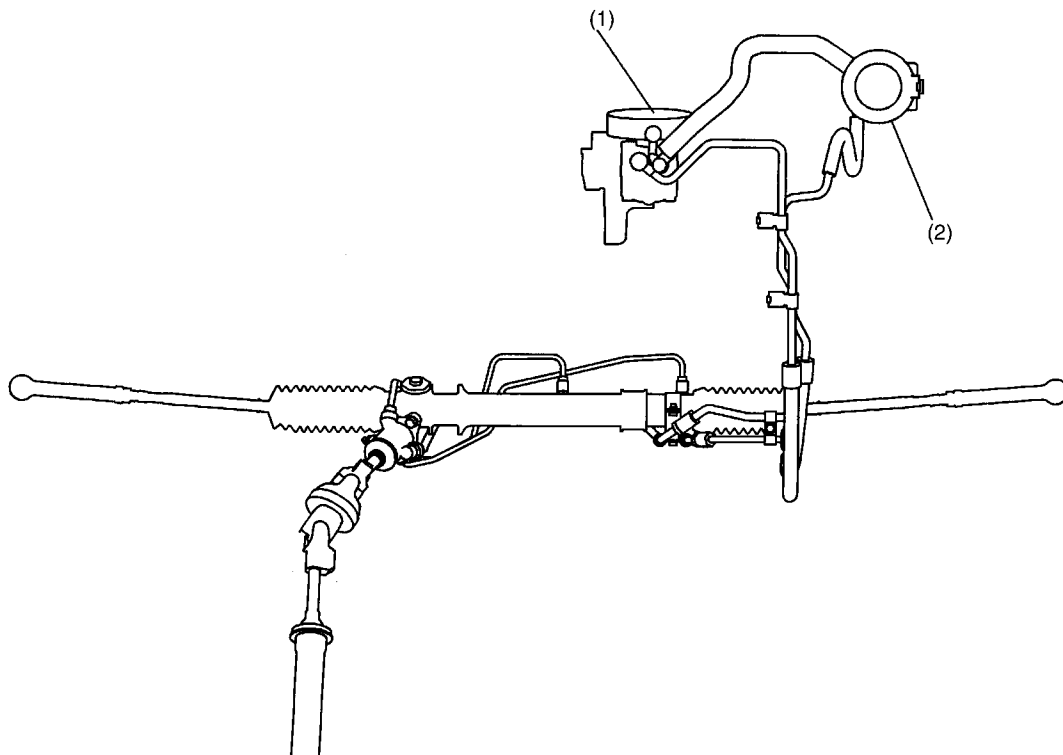

- (1) Fluid pump
- (2) Reservoir tank

B4H1720B

POWER STEERING SYSTEM

Power Assisted System (Power Steering)

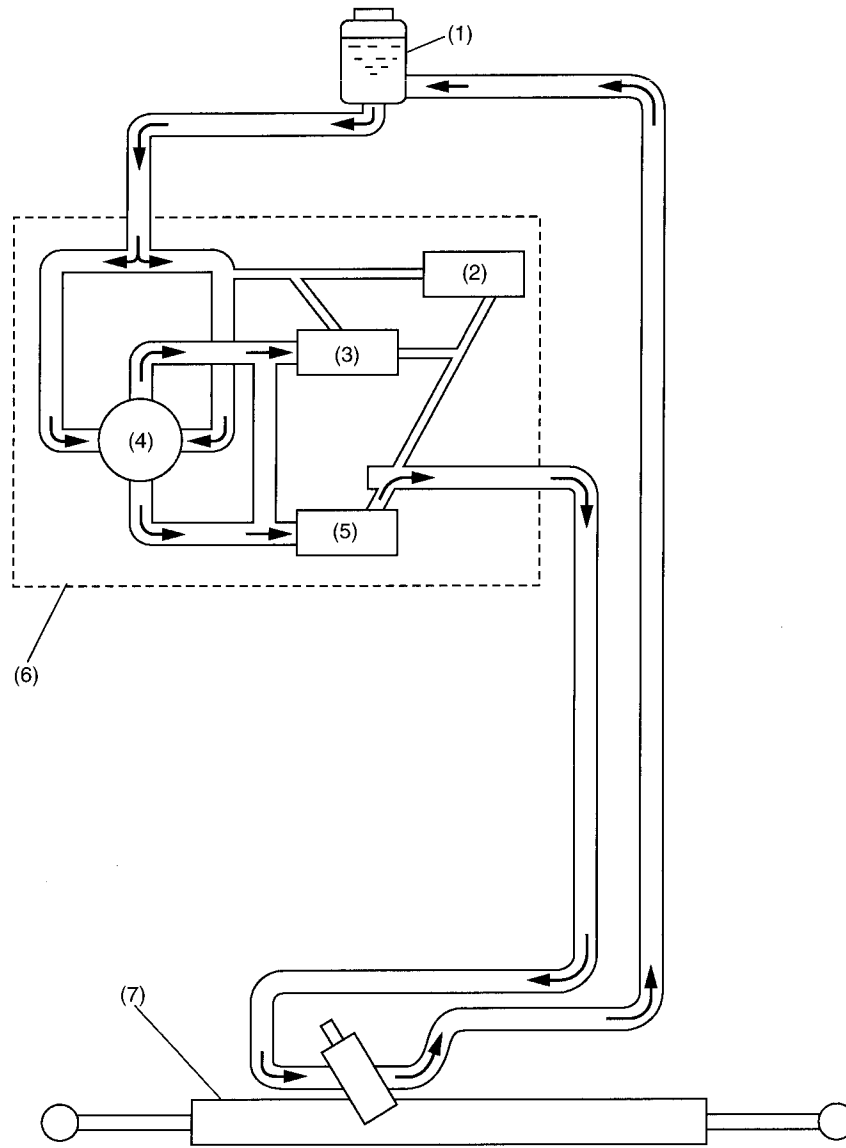

B4H1764B

- | | |
|------------------------------|------------------------|
| (1) Reservoir tank | (5) Flow control valve |
| (2) Relief valve | (6) Fluid pump |
| (3) Pressure-sensitive valve | (7) Steering gearbox |
| (4) Vane pump | |

POWER STEERING SYSTEM

Power Assisted System (Power Steering)

• VANE PUMP

The vane pump consists of a rotor, a cam ring, and ten vanes.

When the rotor rotates, the vane movably fitted in each slot of the rotor is radially moved out by centrifugal force and pressed against the inside wall of the cam ring. Since the inside of the cam ring is oval-shaped, the fluid from the suction port is confined and pressurized in the chamber formed between two adjacent vanes as the rotor rotates and is delivered through the discharge port. The pressurized fluid circulates through the hydraulic circuit.

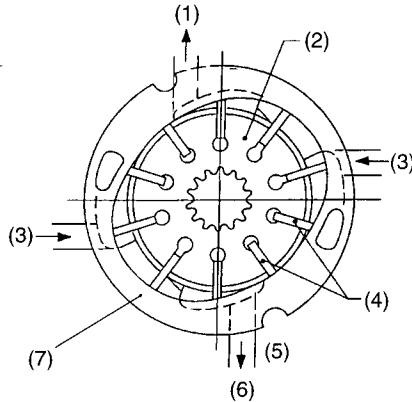

- (1) Discharge
- (2) Rotor
- (3) Suction
- (4) Vane

- (5) Vane pump
- (6) Discharge
- (7) Cam ring

H4H1188C

POWER STEERING SYSTEM

Power Assisted System (Power Steering)

• FLOW CONTROL VALVE

The flow control valve consists of a sub-spool which is pushed to the right when the fluid pressure rises as the engine speed increases (and consequently, the pump discharge rate becomes higher). When the sub-spool is shifted to the right, the variable orifice is narrowed, thus the discharge rate is reduced.

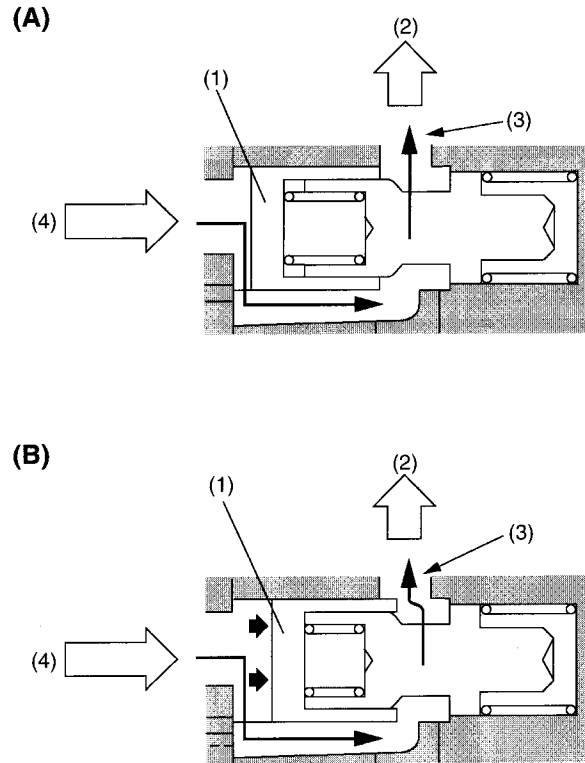

- (A) Engine speed low
- (B) Engine speed high

- (1) Sub-spool
- (2) To steering gearbox
- (3) Variable orifice
- (4) From vane pump

B4H1721B

POWER STEERING SYSTEM

Power Assisted System (Power Steering)

• PRESSURE-SENSITIVE VALVE

The pressure-sensitive valve's left end is exposed to the fluid pump discharge-pressure and its right end to the flow control valve outlet pressure (the pressure of the fluid being directed to the steering gearbox).

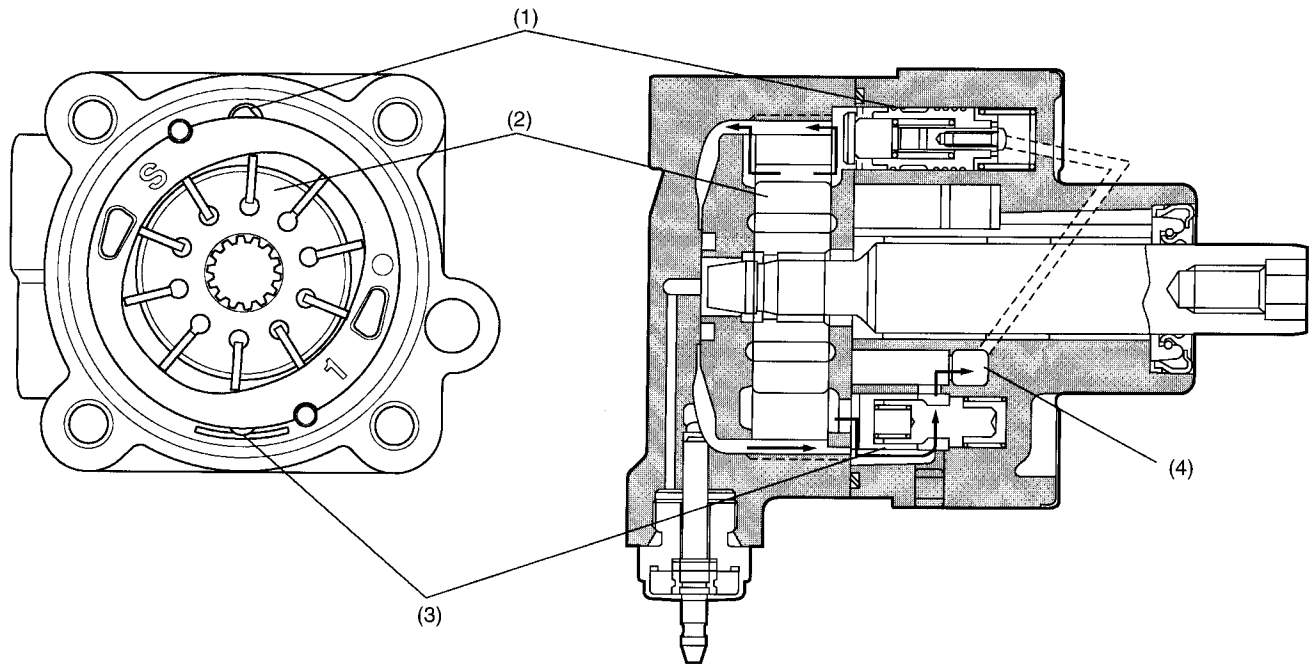

B4H1722B

- (1) Pressure-sensitive valve
- (2) Fluid pump

- (3) Flow control valve
- (4) To steering gearbox

POWER STEERING SYSTEM

Power Assisted System (Power Steering)

● When the steering wheel is not being turned, the fluid that has passed through the flow control valve is directed to the steering gearbox but it is returned to the reservoir tank without entering the rotary control valve's passages in the gearbox. Therefore, the pressure acting on the valve's right end does not increase.

On the other hand, the pressure acting on the left end of valve is the fluid pump-discharge pressure which is higher than the pressure acting on the right end. This causes the pressure-sensitive valve's spool assembly to move to the right. As a result, the drain port which was closed by the outer spool is now opened. The pump discharged fluid then flows to the reservoir tank and the pressure inside the pump is reduced.

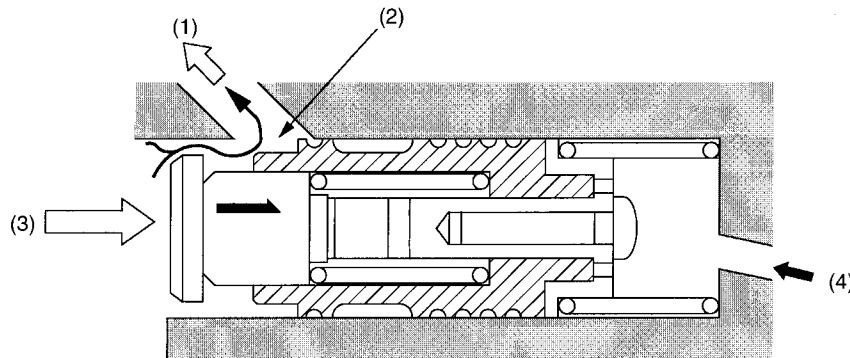

B4H1723B

- (1) To reservoir tank
- (2) Drain port open

- (3) Pressure from vane pump (high)
- (4) Fluid pressure after passing through flow control valve (low)

POWER STEERING SYSTEM

Power Assisted System (Power Steering)

● When the steering wheel is turned in either direction, the pressure of the fluid that has passed through the flow control valve and directed into the steering gearbox increases as it enters the power cylinder and acts on the rack piston.

The inner spool of the pressure-sensitive valve is kept pressed to the right by the pump-discharge pressure acting on its left end. On the other hand, the fluid pressure acting on the right end of the valve is also high. So, the outer spool is moved to the left, closing the drain port. As a result, the pump internal pressure increases so that the fluid with a high pressure necessary for power assistance is supplied to the gearbox.

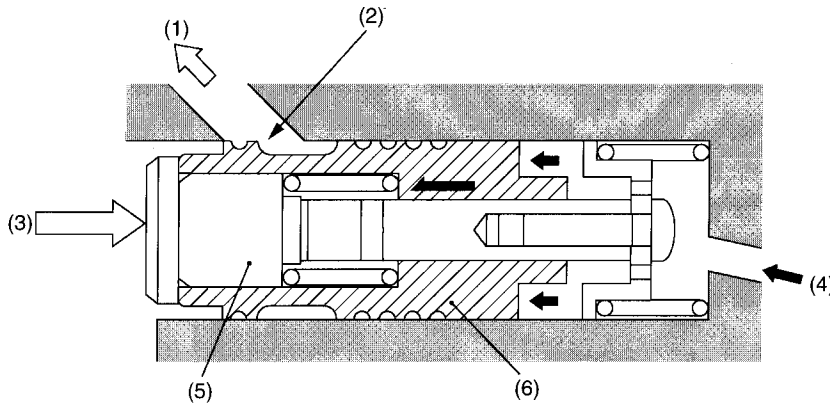

B4H1724B

- | | |
|-----------------------------|---|
| (1) To reservoir tank | (4) Fluid pressure after passing through flow control valve (increased) |
| (2) Drain port closed | (5) Inner spool |
| (3) Pressure from vane pump | (6) Outer spool |

POWER STEERING SYSTEM

Power Assisted System (Power Steering)

• RELIEF VALVE

The relief valve consists of a check ball and a spring. The check ball is exposed to the fluid pressure that is regulated by the flow control valve (branched from the line to the steering gearbox).

If the pressure acting on the check ball is increased abnormally due to, for example, rotation of the steering wheel to a stop and overcomes the spring tension, the ball is pushed to the left, allowing the fluid to be drained into the reservoir tank. Therefore, the pressure to the steering gearbox is prevented from becoming excessively high.

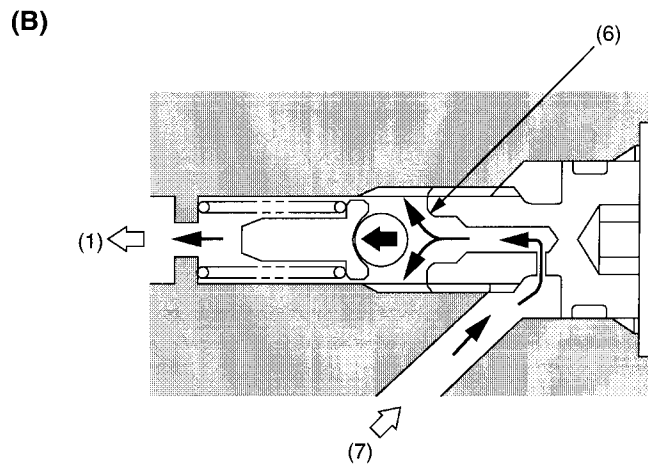
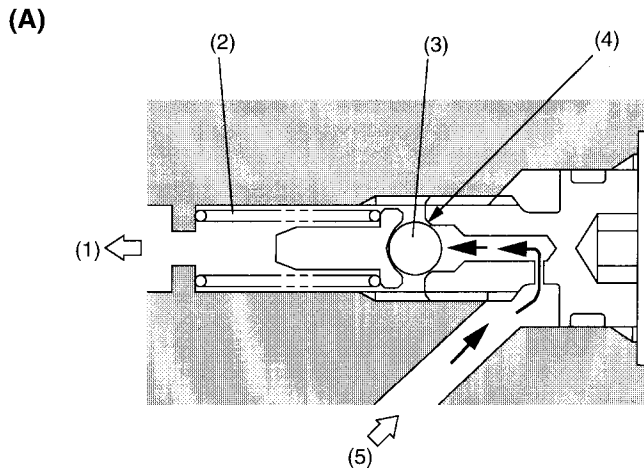

B4H1778B

(A) Relief valve not in operation

(B) Relief valve in operation

(1) To reservoir tank

(2) Spring

(3) Check ball

(4) Valve closed

(5) Fluid pressure after passing through flow control valve (low)

(6) Valve open

(7) Fluid pressure after passing through flow control valve (higher than preset level)

POWER STEERING SYSTEM

Power Assisted System (Power Steering)

2. 3.0ℓ MODEL

- The reservoir tank is mounted on the vehicle body.
- The fluid pump is belt-driven by the engine. The fluid flow is controlled according to the engine speed so that an adequate steering resistance is given during high-speed operation. The fluid pump is a variable capacity type vane pump whose delivery rate per rotation decreases as the engine speed increases. The pump is integral with a pump control valve and relief valve.

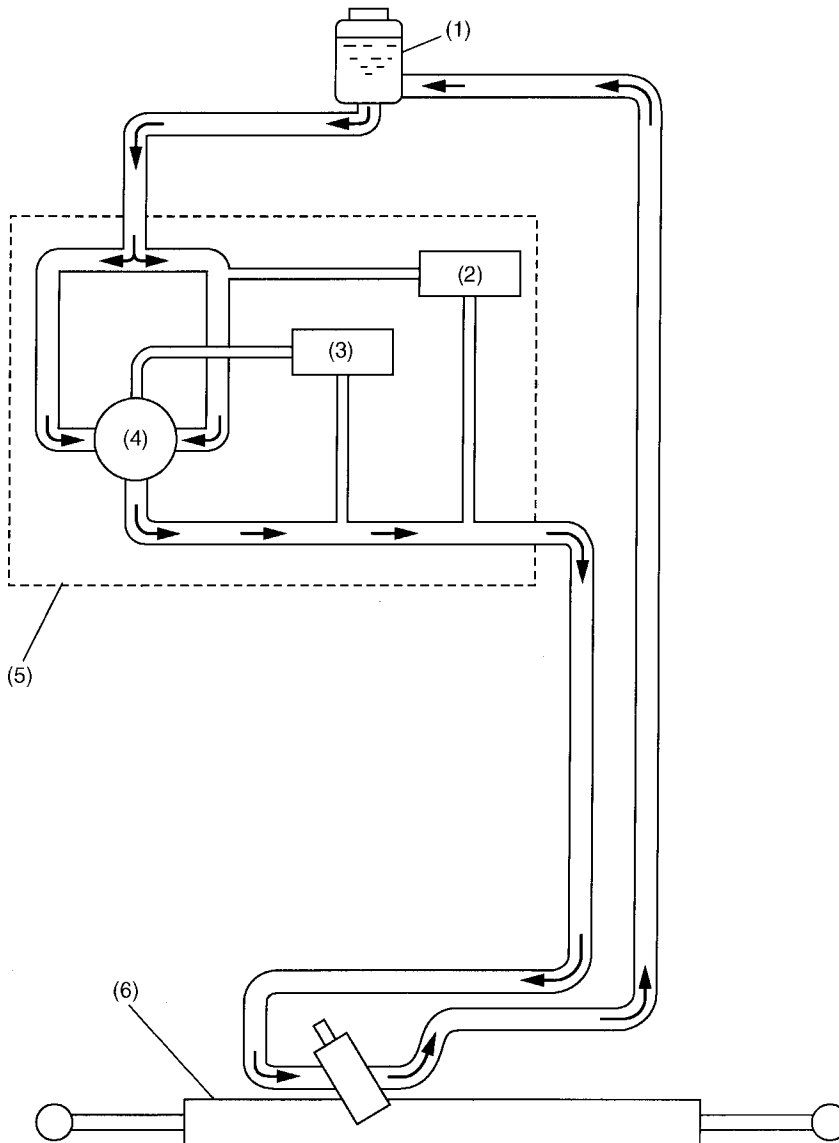

B4H2453A

- | | |
|------------------------|-------------------------|
| (1) Reservoir tank | (4) Vane pump |
| (2) Relief valve | (5) Fluid pump assembly |
| (3) Pump control valve | (6) Steering gearbox |

POWER STEERING SYSTEM

Power Assisted System (Power Steering)

● The vane pump consists of a rotor, a cam ring, and eleven vanes. When the rotor rotates, the vane in each slot of the rotor is radially moved out by centrifugal force and pressed against the cam ring. The fluid from the suction port is confined in chambers formed between two adjacent vanes and carried to the discharge port. Since the cam ring is movable in relation to the rotor, the volume of each chamber is variable. This enables the delivery rate per rotation of the pump to be changed.

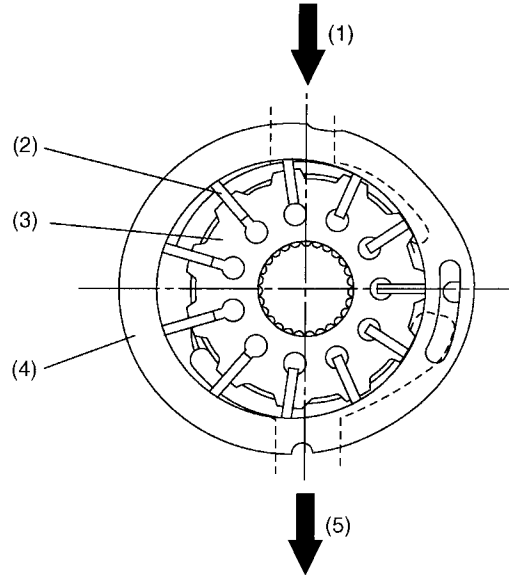

- (1) Suction
- (2) Vane
- (3) Rotor
- (4) Cam ring
- (5) Discharge

B4H2478A

POWER STEERING SYSTEM

Power Assisted System (Power Steering)

• FLOW CONTROL

The variable capacity pump changes its delivery rate per rotation by changing the degree of eccentricity of the cam ring according to its rotating speed (engine speed).

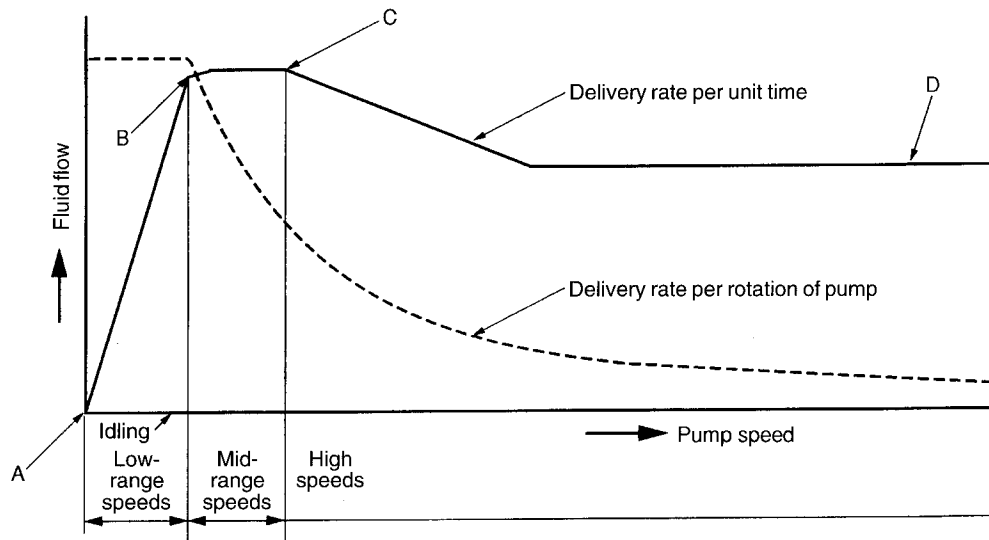

S4H0028B

NOTE:

In the following description, pump speed ranges will be indicated using the speed points A through D shown in the drawing above.

POWER STEERING SYSTEM

Power Assisted System (Power Steering)

Low-range-speed operation (A – B range)

In this speed range, as well as in all the other speed ranges, two different pump discharge pressures are always applied to the control valve; one is directly led from the discharge port to the left end of the valve and the other is led through an orifice (variable orifice) to the right end of the valve. Since the orifice has a pressure reducing effect, the latter pressure is lower than the former. When the pump is operating at a low speed, its discharge pressure is also low, resulting in only small difference between the two pressures. In this condition, the valve stays pushed leftward by the spring, allowing the non-pressurized reservoir tank fluid to enter chamber A. To chamber B, on the other hand, the orifice-reduced discharge pressure is applied, so the cam ring is pushed leftward by the cam ring spring. This makes the eccentricity of the cam ring a maximum and, therefore, the delivery rate per rotation of the pump become a maximum.

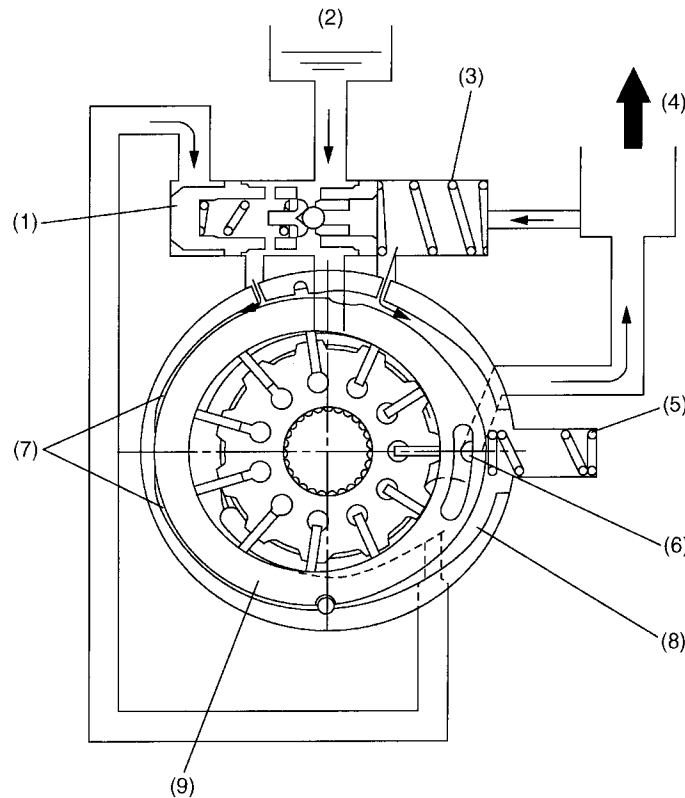

B4H2479A

- | | |
|--------------------------|------------------------|
| (1) Control valve | (6) Variable orifice |
| (2) Reservoir tank fluid | (7) Pressure chamber A |
| (3) Control valve spring | (8) Pressure chamber B |
| (4) Gear box | (9) Cam ring |
| (5) Cam ring spring | |

POWER STEERING SYSTEM

Power Assisted System (Power Steering)

Mid-range-speed operation (B – D range)

During mid-range speed operation, the pump increases its delivery rate. Since the pressure before passing through the variable orifice increases, the control valve moves rightward, overcoming the tension of the control valve spring. This movement of the control valve allows the pressure upstream of the variable orifice to be directed to chamber A after being adjusted to a necessary pressure* by the port opening area created by the control valve. On the other hand, chamber B receives the reservoir pressure (suction pressure). This means that the pressure in chamber A is higher than that in chamber B. As a result, the cam ring moves rightward against the tension of the cam spring. This causes the delivery rate per rotation of the pump to be reduced, so that the flow rate of the fluid to the steering gear box decreases accordingly.

The above control is performed when the pump is operating at a speed in the B – D range.

* The “necessary pressure” for chamber A is a pressure required to move the cam ring to the position corresponding to each predetermined flow rate (pump delivery rate). The pressure is obtained by changing the port opening area appropriately through displacement of the control valve. The displacement of the control valve is determined by how much the pressure before the variable orifice is different from that after the orifice.

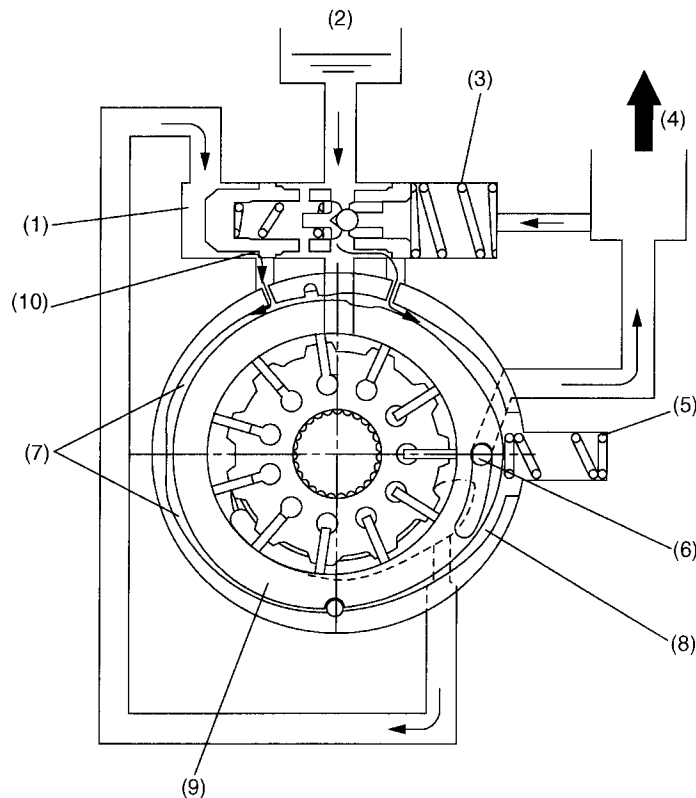

B4H2480A

- | | |
|--------------------------|------------------------|
| (1) Control valve | (6) Variable orifice |
| (2) Reservoir tank fluid | (7) Pressure chamber A |
| (3) Control valve spring | (8) Pressure chamber B |
| (4) Gear box | (9) Cam ring |
| (5) Cam ring spring | (10) Opening area |

POWER STEERING SYSTEM

Power Assisted System (Power Steering)

Maximum pressure control

When the hydraulic circuit in the steering gear box is closed as a result of a steering action, the pressure in the circuit increases to a very high level. The relief valve prevents the pressure from exceeding a preset safe level in the following way:

If the fluid in the circuit is pressurized to the preset pressure, the fluid pushes the ball of the valve overcoming the tension of the relief spring. Through the opened relief valve, the fluid makes its way to the pump's suction side passage, thus maintaining the circuit pressure at a level lower than the preset pressure.

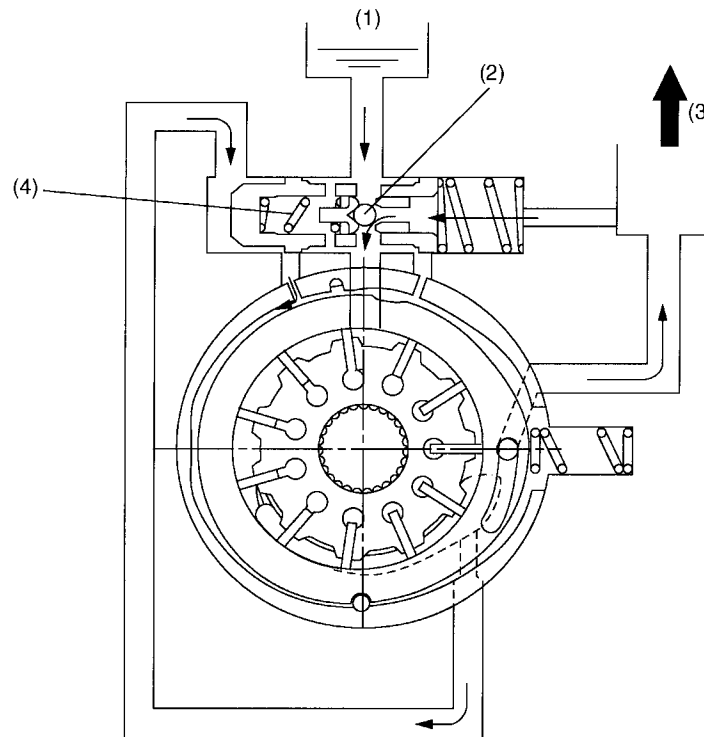

B4H2481A

- (1) Reservoir tank fluid
- (2) Relief valve
- (3) Gear box
- (4) Relief spring