

REAR SUSPENSION

Rear Suspension

1. Rear Suspension

A: OUTLINE

The rear suspension is a multilink type. This type of suspension is characterized by small changes in camber and toe-in against external input of vertical, longitudinal and lateral forces. This enables full use of tire performance and ensures high kinetic performance and stability of the vehicle.

This suspension also features quiet operation because the front link, rear link, upper link and rear differential are all attached to a subframe which in turn is installed to the vehicle body through heavy-duty bushings.

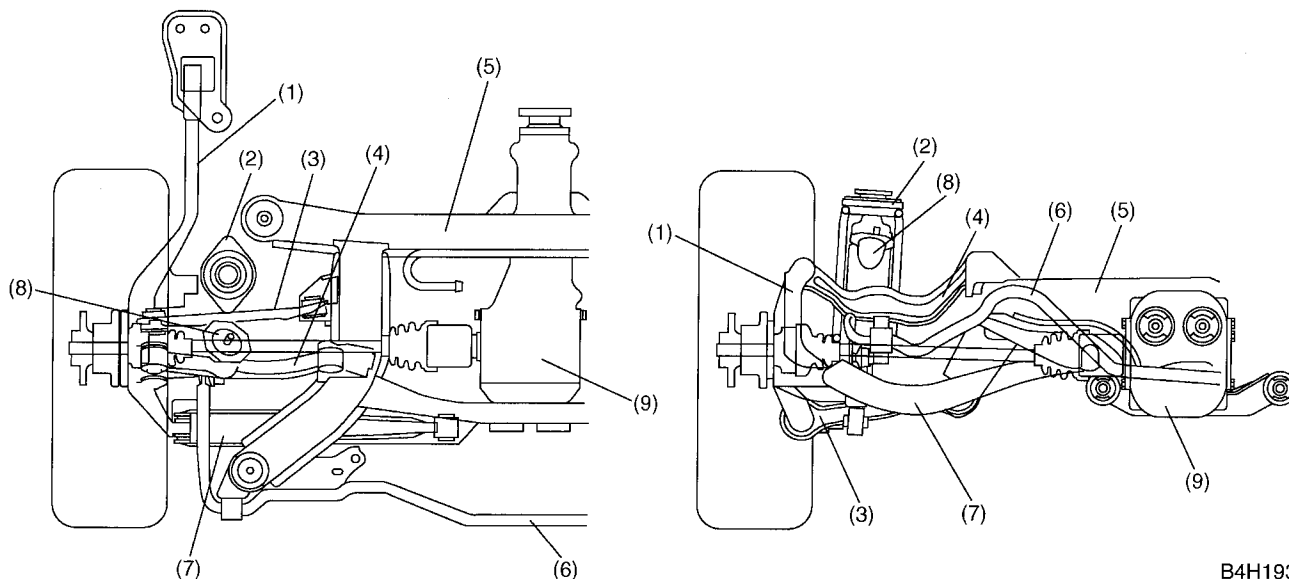

B4H1933A

- | | | |
|------------------------------------|----------------|-----------------------|
| (1) Rear arm | (4) Upper link | (7) Rear link |
| (2) Shock absorber and coil spring | (5) Subframe | (8) Helper |
| (3) Front link | (6) Stabilizer | (9) Rear differential |

Component	Key feature	Function
Rear arm	Made of cast iron for sufficient rigidity.	Supports longitudinal dynamic load.
Front link	Made of sheet metal with U-shaped section for sufficient rigidity.	Supports lateral dynamic load.
Rear link	Made of sheet metal with U-shaped section for sufficient rigidity.	Supports lateral dynamic load.
Upper link	Made of cast iron for sufficient rigidity against impact from helper when suspension is bumped.	Supports lateral dynamic load.
Shock absorber and coil spring	Overall length is optimally minimized to eliminate protrusion into the passenger compartment.	Supports and controls vertical dynamic load.
Stabilizer	Ball joint type stabilizer link is used to minimize transient rolling of the body.	Controls body rolling.
Helper	Attached to the body independently of shock absorber to avoid its protrusion into the passenger compartment.	Combined with upper link to serve as vehicle bump stopper.
Subframe	Attached to the body through heavy duty bushings for quiet operation.	Supports front link, rear link, upper link and rear differential.