

## 6. Oil Seal and Packing S601546

### A: REPLACEMENT S601546A20

#### 1. VALVE HOUSING OIL SEAL S601546A2001

**Specified steering grease:**  
**VALIANT GREASE M2 (Part No. 003608001)**

- 1) Pry off dust seal using screwdriver.
- 2) Remove snap ring using snap ring pliers.

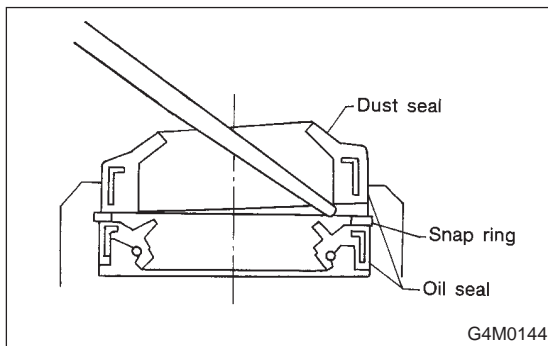

- 3) Pry off oil seal using screwdriver.

**CAUTION:**  
 After removing, check inside surface of valve housing for damage. If oil seal contacting surface is damaged, replace valve housing with a new one.

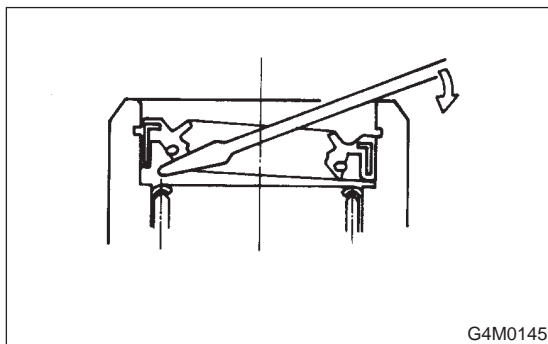

- 4) Press-fit oil seal into valve housing using ST and press.  
 ST 927610000 INSTALLER

**NOTE:**  
 Before fitting, coat oil seal fully with ATF DEXRON IIE or ATF DEXRON III.

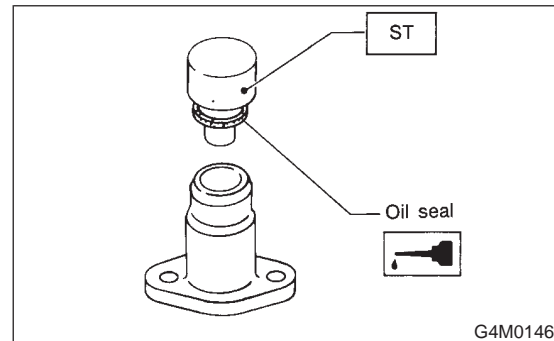

- 5) Fit snap ring in snap ring groove using snap ring pliers.

**CAUTION:**  
 Be careful not to scratch oil seal with snap ring pliers.

**NOTE:**  
 Rotate snap ring to check for proper installation.

#### 2. PINION AND VALVE ASSEMBLY S601546A2002

- 1) Remove snap ring using snap ring pliers.

**CAUTION:**

- Do not reuse removed snap ring.
- Be careful not to scratch pinion and valve assembly.

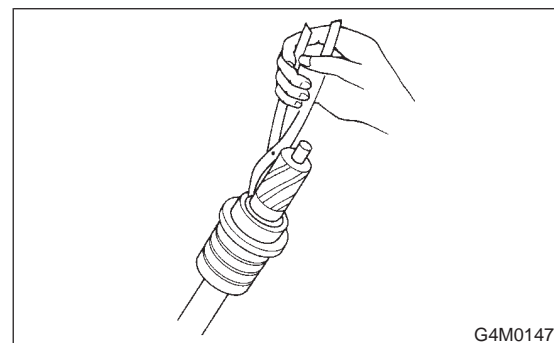

# OIL SEAL AND PACKING

Power Assisted System (Power Steering)

2) Press out bearing together with backing washer using pipe of I.D. 38.5 to 39.5 mm (1.516 to 1.555 in) and press.

**CAUTION:**

**Do not reuse removed bearing.**

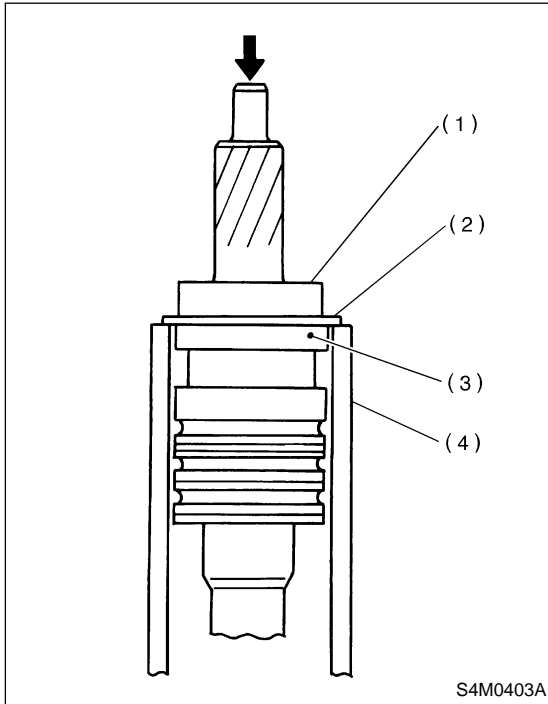

- (1) Bearing
- (2) Backing washer
- (3) Oil seal
- (4) Pipe

3) Remove oil seal.

**CAUTION:**

**Do not reuse removed oil seal.**

4) Put vinyl tape around pinion shaft splines to protect oil seal from damage.

5) Fit pinion and valve assembly into valve housing.

**NOTE:**

Apply specified power steering fluid to outer diameter surface of input shaft and outer surface of valve body seal ring, and pay special attention not to damage seal when inserting pinion and valve assembly.

6) Secure valve assembly to ST1 and ST2.

7) Put ST3 over pinion, and insert oil seal, then force-fit oil seal into housing using ST4.

- ST1 926370000 INSTALLER A
- ST2 34099FA100 STAND BASE
- ST3 926360000 INSTALLER A
- ST4 927620000 INSTALLER B

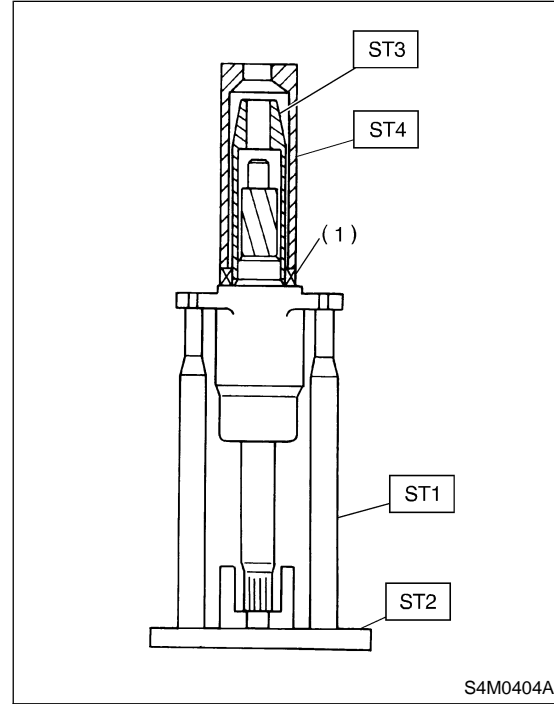

- (1) Oil seal

**NOTE:**

- Apply specified power steering fluid to oil seal and ST3, being careful not to damage oil seal lip.
- Push oil seal until ST3 contacts housing end face.

8) Remove ST3, and fit backing washer.

9) Force-fit ball bearing using ST3.

- ST1 926370000 INSTALLER A
- ST2 34099FA100 STAND BASE
- ST3 927640000 INSTALLER B

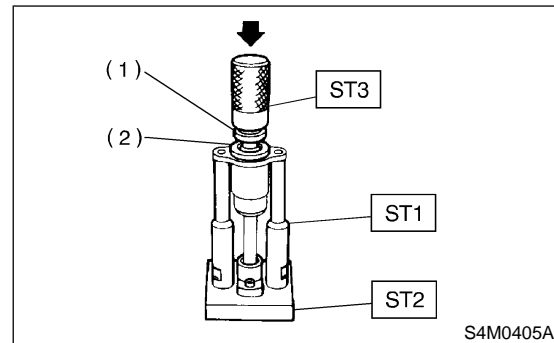

- (1) Ball bearing
- (2) Backing washer

# OIL SEAL AND PACKING

Power Assisted System (Power Steering)

**NOTE:**

Be careful not to tilt ball bearing during installation.

10) Install snap ring using snap ring pliers.

**NOTE:**

Rotate snap ring to check for proper installation.

### 3. RACK HOUSING OIL SEAL S601546A2003

1) Insert ST from pinion housing side and remove oil seal using a press.

ST 34199AE050 REMOVER OIL SEAL

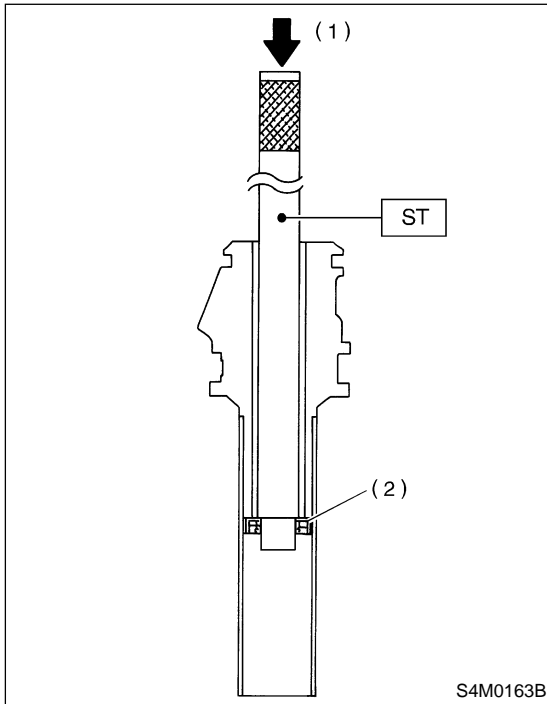

- (1) Press
- (2) Oil seal

**NOTE:**

Discard removed oil seal.

2) Force-fit oil seal using ST.  
ST 34199AE050 INSTALLER

**CAUTION:**

**Be careful not to damage or scratch cylinder inner wall.**

**NOTE:**

- Apply specified power steering fluid to oil seal.
- Pay special attention not to install oil seal in wrong direction.
- Push oil seal until the stepped portion of A contacts end face of B.

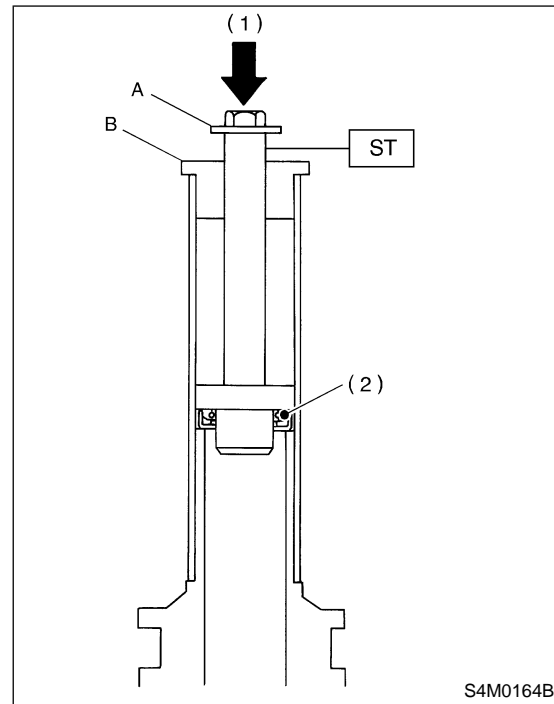

- (1) Press
- (2) Oil seal