

# PURGE CONTROL SOLENOID VALVE

Emission Control (Aux. Emission Control Devices)

## 5. Purge Control Solenoid Valve

S140035

### A: REMOVAL

S140035A18

- 1) Disconnect battery ground cable.

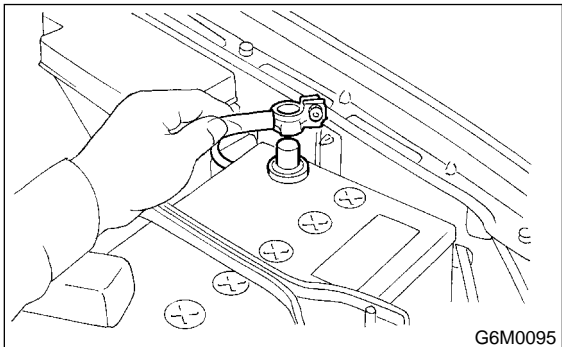

- 2) Remove power steering pump from bracket.
  - (1) Remove air intake duct and air cleaner case. <Ref. to IN(H6)-5, REMOVAL, Air Cleaner.> and <Ref. to IN(H6)-7, REMOVAL, Air Intake Duct.>
  - (2) Remove V-belt. <Ref. to ME(H6)-31, REMOVAL, V-belt.>
  - (3) Remove power steering oil pipe with bracket.

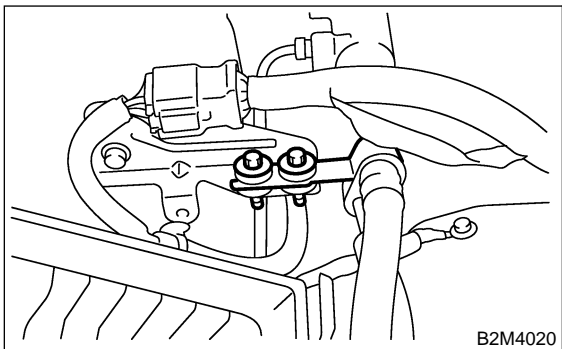

- (4) Remove bolts which install power steering pump bracket.

#### CAUTION:

Do not separate hose and pipe from the pump main unit.

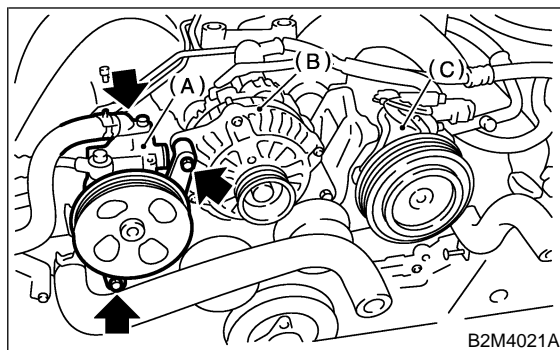

- (A) Power steering pump
- (B) Generator
- (C) A/C compressor

- (5) Remove power steering tank from the bracket by pulling it upward.

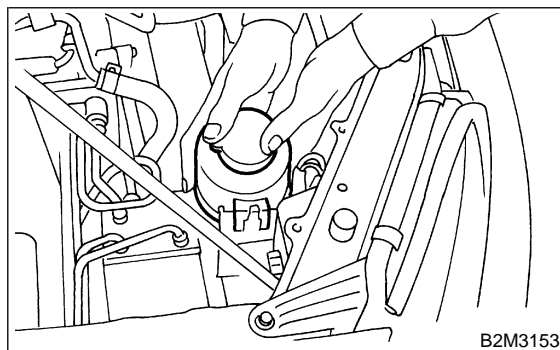

- (6) Place power steering pump on the right side wheel apron.

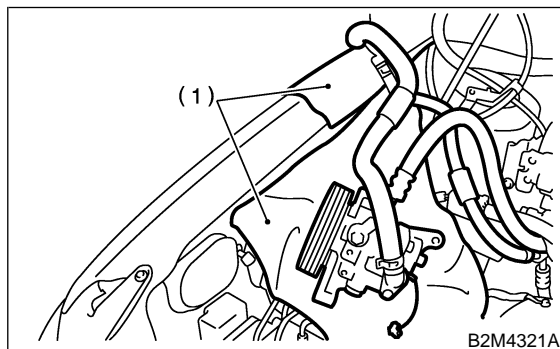

- (1) Cloth

# PURGE CONTROL SOLENOID VALVE

Emission Control (Aux. Emission Control Devices)

3) Disconnect connector and hoses from purge control solenoid valve.

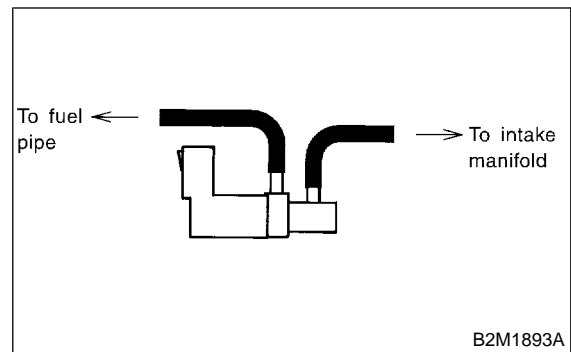
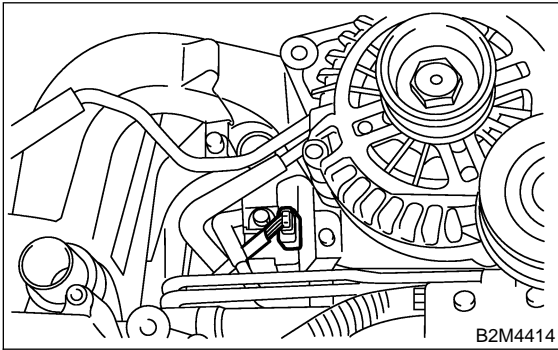

4) Remove bolt which installs purge control solenoid valve onto intake manifold.

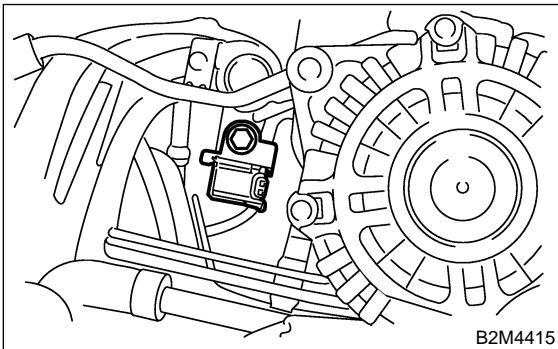

5) Take out purge control solenoid valve through the bottom of the intake manifold.

## B: INSTALLATION S140035A11

Install in the reverse order of removal.

### **Tightening torque:**

**16 N·m (1.6 kgf·m, 11.6 ft·lb)**

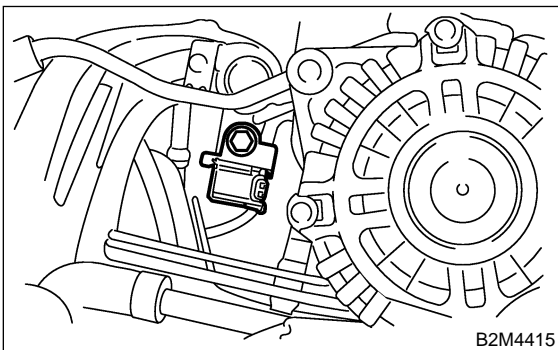

**CAUTION:**  
Carefully connect the evaporation hoses.

## C: INSPECTION S140035A10

Make sure hoses are not cracked or loose.