

# EGR VALVE

Emission Control (Aux. Emission Control Devices)

## 6. EGR Valve S140738

### A: REMOVAL S140738A18

- 1) Disconnect battery ground cable.

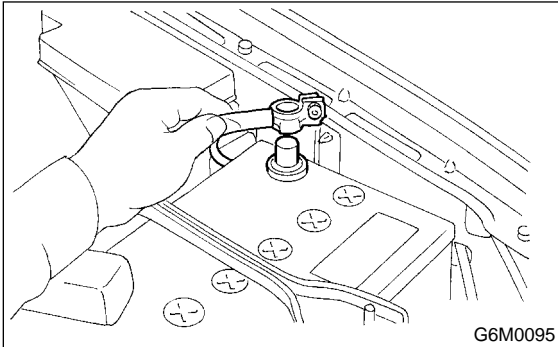

- 2) Remove air duct.
- 3) Remove starter. <Ref. to SC(H6)-6, REMOVAL, Starter.>
- 4) Remove EGR pipe from EGR valve and cylinder head.

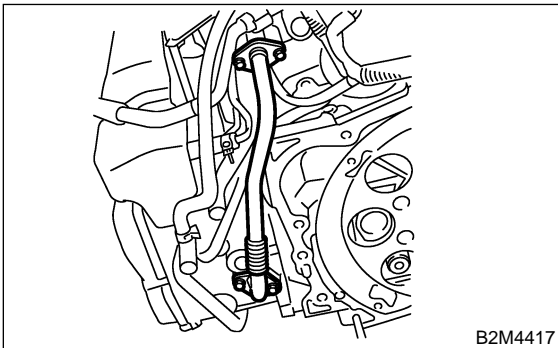

- 5) Remove EGR valve from intake manifold.

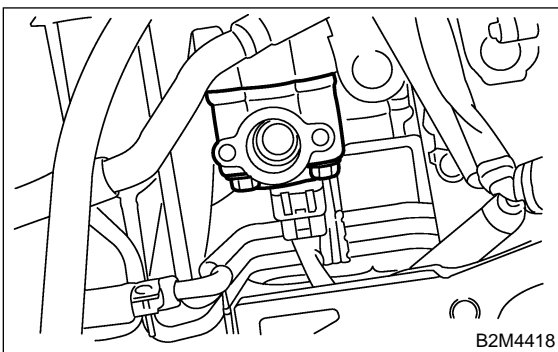

- 6) Disconnect connector from EGR valve.

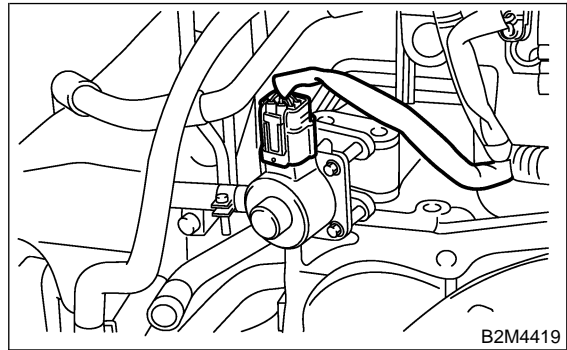

### B: INSTALLATION S140738A11

NOTE:

Replace old gaskets with new one.

- 1) Connect connector EGR valve.

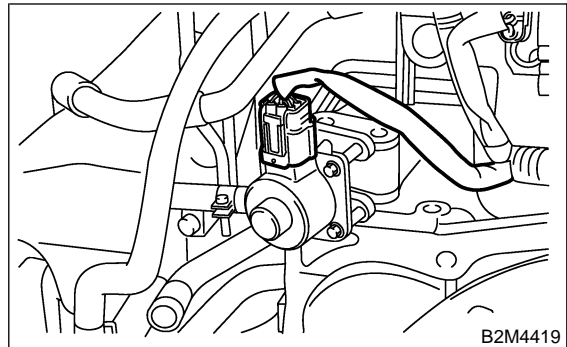

- 2) Install EGR valve to intake manifold.

**Tightening torque:**

**19 N·m (1.9 kgf·m, 14 ft·lb)**

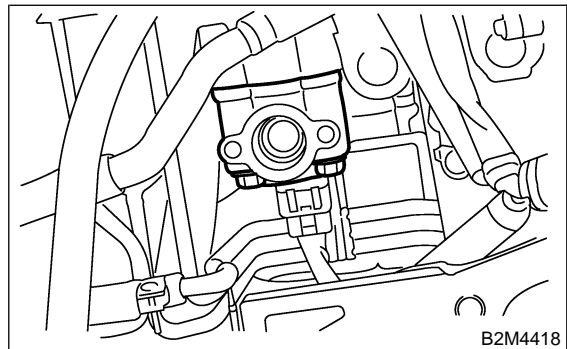

- 3) Install EGR pipe to EGR valve and cylinder head.

# EGR VALVE

Emission Control (Aux. Emission Control Devices)

## Tightening torque:

**6.4 N·m (0.65 kgf-m, 4.7 ft-lb)**

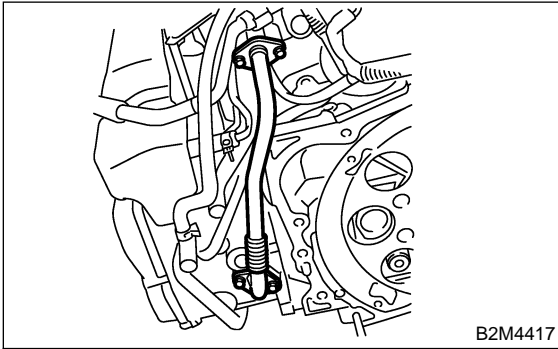

- 4) Install starter. <Ref. to SC(H6)-6, INSTALLATION, Starter.>
- 5) Install air duct.
- 6) Connect battery ground cable.

## C: INSPECTION S140738A10

- 1) Check the EGR valve for proper valve movement.
- 2) Check the EGR pipe, etc., for blockages or cracks.