

12. Inspection Mode S048510

A: OPERATION S048510A16

1. PREPARATION FOR THE INSPECTION MODE S048510A1601

Raise the vehicle using a garage jack and place on safety stands or drive the vehicle onto free rollers.

WARNING:

- Before raising the vehicle, ensure parking brakes are applied.
- Do not use a pantograph jack in place of a safety stand.
- Secure a rope or wire to the front and rear towing or tie-down hooks to prevent the lateral runoff of front wheels.
- Do not abruptly depress/release clutch pedal or accelerator pedal during works even when engine is operating at low speeds since this may cause vehicle to jump off free rollers.
- In order to prevent the vehicle from slipping due to vibration, do not place any wooden blocks or similar items between the safety stands and the vehicle.
- Since the rear wheels will also rotate, do not place anything near them. Also, make sure that nobody goes in front of the vehicle.

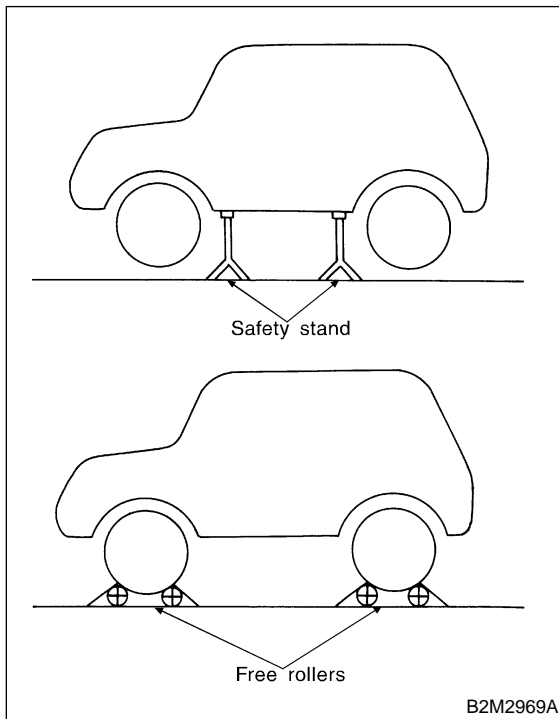

2. SUBARU SELECT MONITOR S048510A1602

After performing diagnostics and clearing the memory, check for any remaining unresolved trouble data.

- 1) Prepare Subaru Select Monitor kit. <Ref. to EN(H6)-8 PREPARATION TOOL, General Description.>

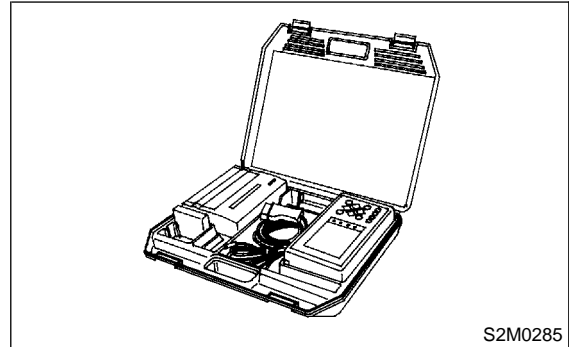

- 2) Connect diagnosis cable to Subaru Select Monitor.
- 3) Insert cartridge into Subaru Select Monitor. <Ref. to EN(H6)-8 PREPARATION TOOL, General Description.>

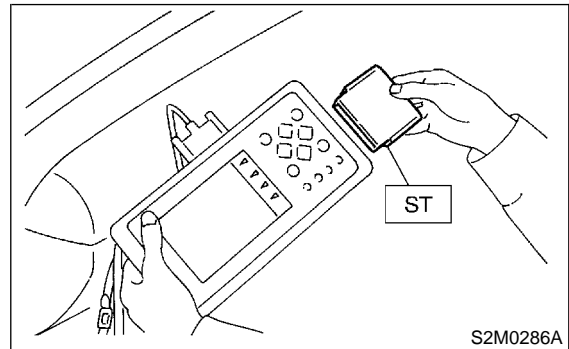

- 4) Connect test mode connector at the lower portion of instrument panel (on the driver's side), to the side of the center console box.

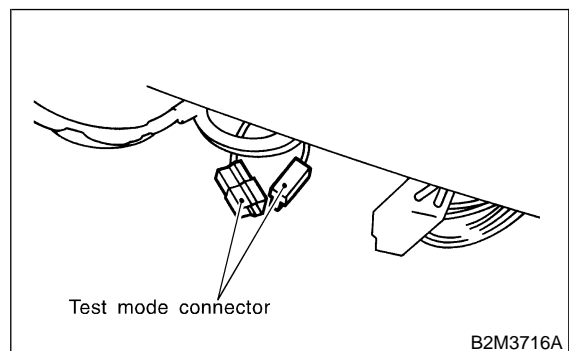

INSPECTION MODE

Engine (DIAGNOSTICS)

5) Connect Subaru Select Monitor to data link connector.

(1) Connect Subaru Select Monitor to data link connector located in the lower portion of the instrument panel (on the driver's side).

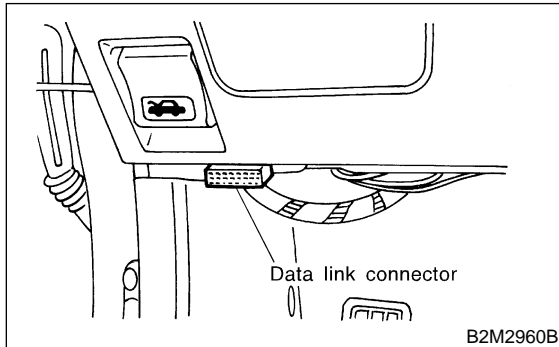

(2) Connect diagnosis cable to data link connector.

CAUTION:

Do not connect scan tools except for Subaru Select Monitor and OBD-II general scan tool.

6) Turn ignition switch to ON (engine OFF) and Subaru Select Monitor switch to ON.

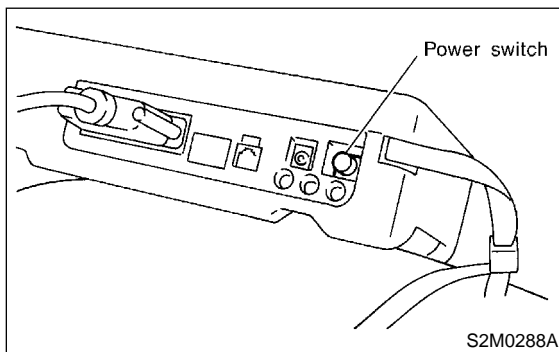

7) On the «Main Menu» display screen, select the {2. Each System Check} and press the [YES] key.

8) On the «System Selection Menu» display screen, select the {Engine Control System} and press the [YES] key.

9) Press the [YES] key after displayed the information of engine type.

10) On the «Engine Diagnosis» display screen, select the {Dealer Check Mode Procedure} and press the [YES] key.

11) When the "Perform Inspection (Dealer Check) Mode?" is shown on the display screen, press the [YES] key.

12) Perform subsequent procedures as instructed on the display screen.

● If trouble still remains in the memory, the corresponding diagnostic trouble code (DTC) appears on the display screen.

NOTE:

● For detailed operation procedure, refer to the SUBARU SELECT MONITOR OPERATION MANUAL.

● For detailed concerning diagnostic trouble codes, refer to the List of Diagnostic Trouble Code (DTC).

<Ref. to EN(H6)-87 List of Diagnostic Trouble Code (DTC).>

● Release the parking brake.

● The speed difference between front and rear wheels may light either the ABS warning light, but this indicates no malfunctions. When engine control diagnosis is finished, perform the ABS memory clearance procedure of self-diagnosis system.

3. OBD-II GENERAL SCAN TOOL S048510A1603

After performing diagnostics and clearing the memory, check for any remaining unresolved trouble data:

1) Connect test mode connector at the lower side of the instrument panel (on the driver's side), to the side of the center console box.

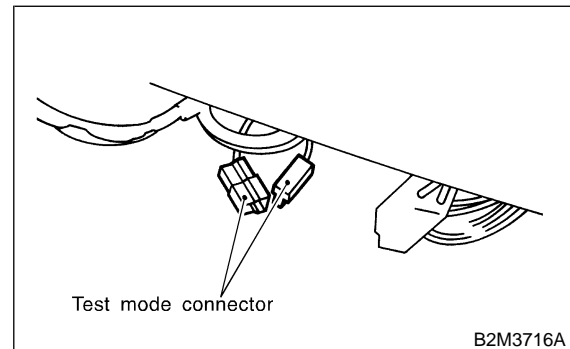

2) Connect the OBD-II general scan tool to its data link connector in the lower portion of the instrument panel (on the driver's side).

CAUTION:

Do not connect the scan tools except for Subaru Select Monitor and OBD-II general scan tool.

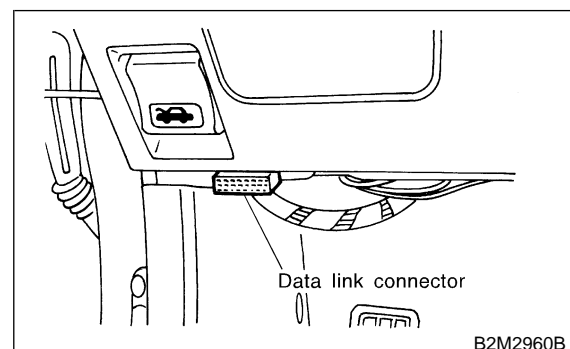

3) Start the engine.

NOTE:

Ensure the selector lever is placed in the “P” position before starting.

- 4) Using the selector lever or shift lever, turn the “P” position switch and the “N” position switch to ON.
- 5) Depress the brake pedal to turn the brake switch ON.
- 6) Keep engine speed in the 2,500 — 3,000 rpm range for 40 seconds.

NOTE:

On models without tachometer, use the tachometer (Secondary pickup type).

- 7) Place the selector lever or shift lever in the “D” position and drive the vehicle at 5 to 10 km/h (3 to 6 MPH).

NOTE:

- On AWD vehicles, release the parking brake.
- The speed difference between front and rear wheels may light the ABS warning light, but this indicates no malfunctions. When engine control diagnosis is finished, perform the ABS memory clearance procedure of self-diagnosis system.

- 8) Using the OBD-II general scan tool, check for diagnostic trouble code(s) and record the result(s).

NOTE:

- For detailed operation procedures, refer to the OBD-II General Scan Tool Instruction Manual.
- For detailed concerning diagnostic trouble codes, refer to the List of Diagnostic Trouble Code (DTC).

<Ref. to EN(H6)-87 List of Diagnostic Trouble Code (DTC).>