

16. Rear Oxygen Sensor S145657

A: REMOVAL S145657A18

- 1) Disconnect battery ground cable.

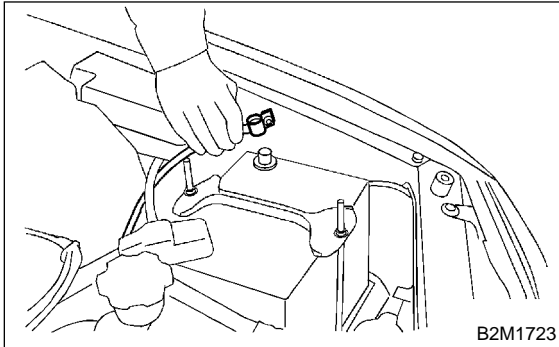

- 2) Disconnect connector from rear oxygen sensor.

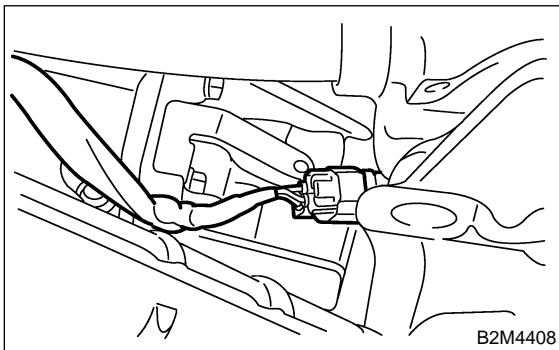

- 3) Lift-up the vehicle.
- 4) Apply SUBARU CRC or its equivalent to threaded portion of rear oxygen sensor, and leave it for one minute or more.

SUBARU CRC (Part No. 004301003)

- 5) Remove rear oxygen sensor.

CAUTION:

When removing, do not force rear oxygen sensor in an unnatural way especially when exhaust pipe is cold, otherwise it will damage exhaust pipe.

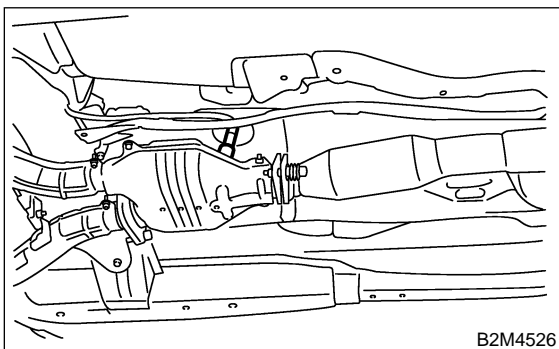

B: INSTALLATION S145657A11

- 1) Before installing rear oxygen sensor, apply anti-seize compound only to threaded portion of rear oxygen sensor to make the next removal easier.

CAUTION:

Never apply anti-seize compound to protector of rear oxygen sensor.

**Anti-seize compound:
SS-30 by JET LUBE**

- 2) Install rear oxygen sensor.

**Tightening torque:
21 N·m (2.1 kgf-m, 15.2 ft-lb)**

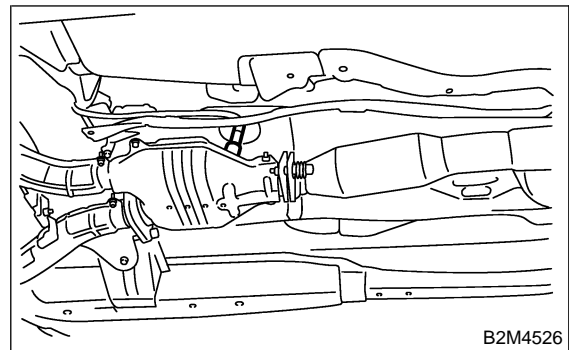

- 3) Connect connector to rear oxygen sensor.

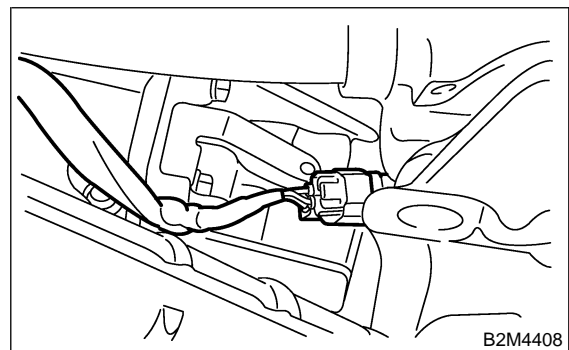

- 4) Lower the vehicle.
- 5) Connect battery ground cable.

