

23. Fuel Pump S145025

A: REMOVAL S145025A18

WARNING:

- Place “NO FIRE” signs near the working area.
- Be careful not to spill fuel on the floor.

NOTE:

Fuel pump assembly consists of fuel pump and fuel level sensor.

- 1) Release fuel pressure. <Ref. to FU(H6)-49 RELEASING OF FUEL PRESSURE, OPERATION, Fuel.>
- 2) Open fuel filler flap lid and remove fuel filler cap.

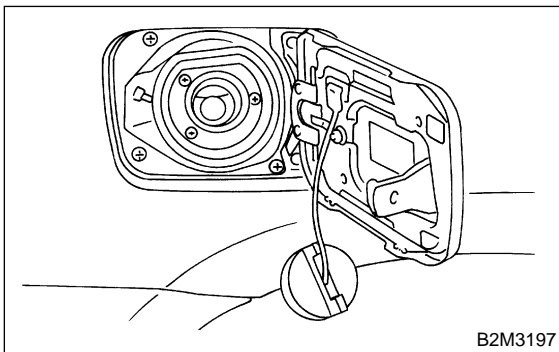

- 3) Disconnect battery ground cable.

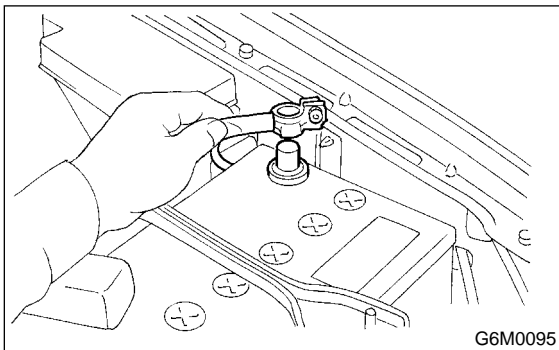

- 4) Lift-up the vehicle.
- 5) Remove front side fuel tank cover.

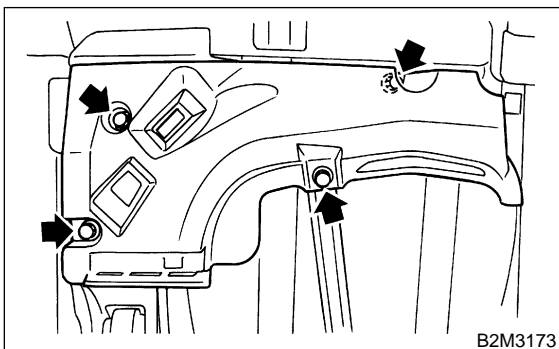

- 6) Drain fuel from fuel tank. Set a container under the vehicle and remove drain plug from fuel tank.

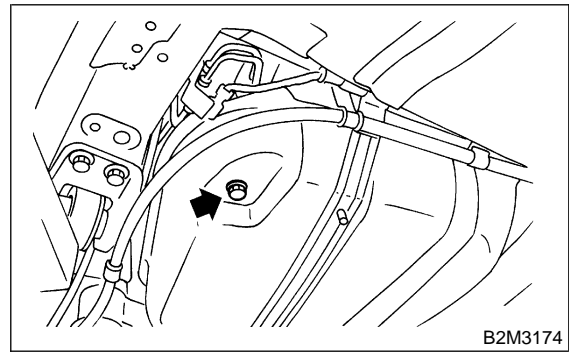

- 7) Tighten fuel drain plug and install front right side fuel tank cover.

Tightening torque:

26 N·m (2.65 kgf·m, 19.2 ft·lb)

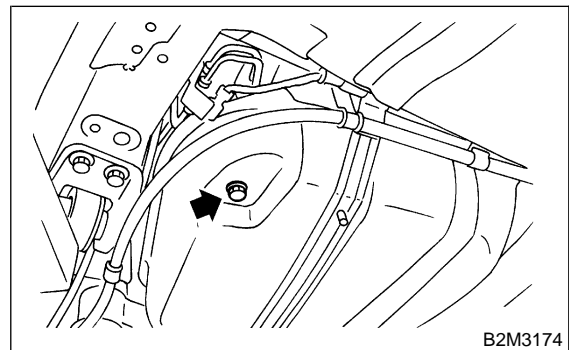

Tightening torque:

18 N·m (1.8 kgf·m, 13.0 ft·lb)

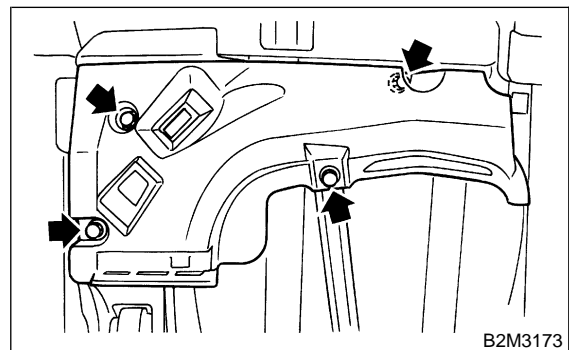

- 8) Raise rear seat and turn floor mat up.

FUEL PUMP

Fuel Injection (Fuel Systems)

- 9) Remove access hole lid.

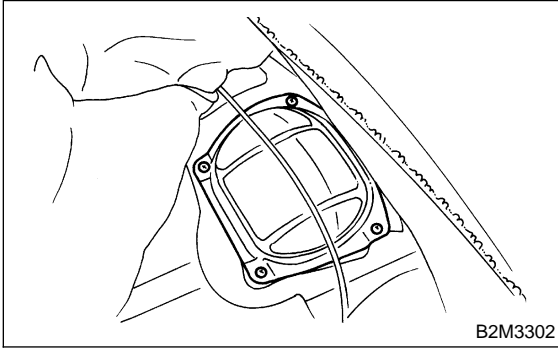

- 10) Disconnect connector from fuel pump.

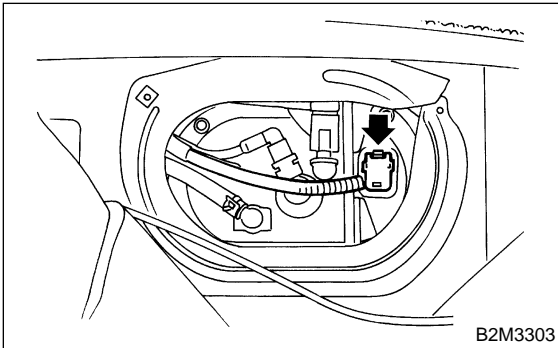

- 11) Move clips and then disconnect jet pump hose (C).

- 12) Disconnect quick connector and then disconnect fuel delivery hose (A) and return hose (B). <Ref. to FU(H6)-77 REMOVAL, Fuel Delivery, Return and Evaporation Lines.>

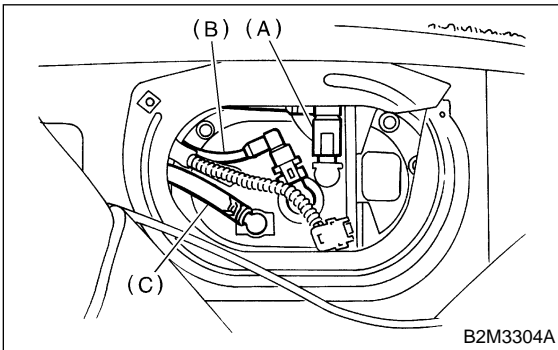

- 13) Remove nuts which install fuel pump assembly onto fuel tank.

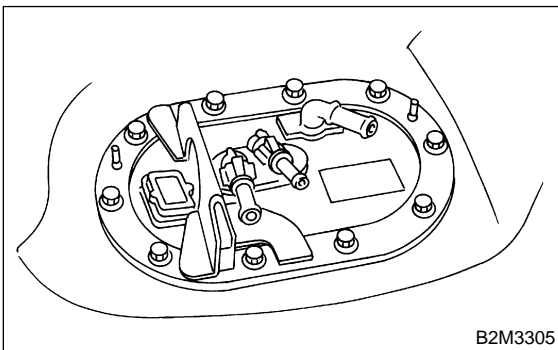

- 14) Take off fuel pump assembly from fuel tank.

B: INSTALLATION S145025A11

Install in the reverse order of removal. Do the following:

- (1) Always use new gaskets.
- (2) Ensure sealing portion is free from fuel or foreign particles before installation.
- (3) Tighten nuts in alphabetical sequence shown in figure to specified torque.

Tightening torque:

5.9 N·m (0.6 kgf-m, 4.3 ft-lb)

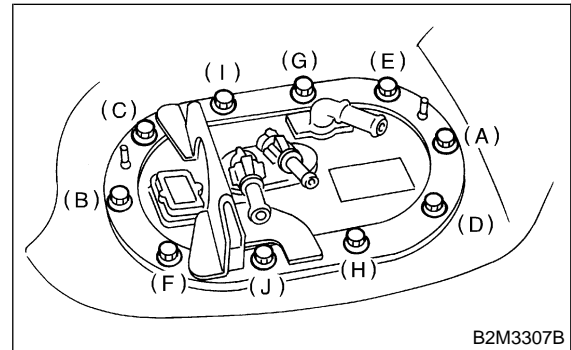

C: DISASSEMBLY S145025A06

- 1) Remove fuel pump and pump holder.

NOTE:

When disassembling pump holder, be careful as it is installed with two pawls.

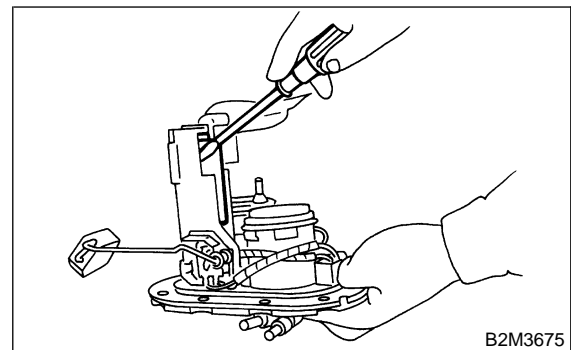

- 2) Disconnect connector from fuel pump.

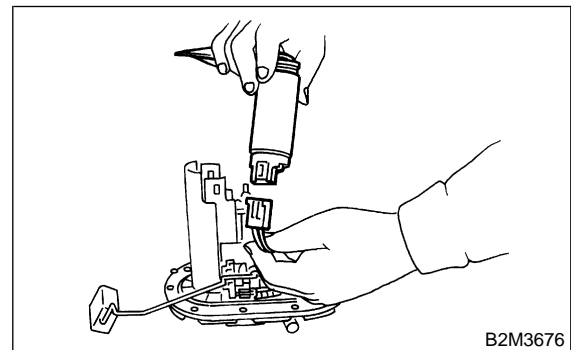

D: ASSEMBLY S145025A02

Assemble in the reverse order of disassembly.

E: INSPECTION S145025A10

Connect lead harness to connector terminal of fuel pump and apply battery power supply to check whether the pump operate.

WARNING:

- Wipe off the fuel completely.
- Keep battery as far apart from fuel pump as possible.
- Be sure to turn the battery supply ON and OFF on the battery side.
- Do not run fuel pump for a long time under no-load condition.

