

7. Engine Assembly S143079

A: REMOVAL S143079A18

- 1) Set the vehicle on lift arms.
- 2) Open front hood fully and support with stay.
- 3) Raise rear seat, and turn floor mat up.
- 4) Release fuel pressure. <Ref. to FU(H6)-49, RELEASING OF FUEL PRESSURE, OPERATION, Fuel.>

(1) Disconnect connector of fuel tank cord from the nearest harness.

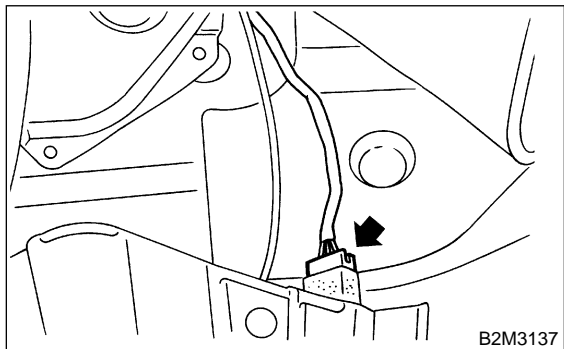

- (2) Start the engine, and run until it stalls.
- (3) After the engine stalls, crank it for five seconds more.
- (4) Turn ignition switch to "OFF".

- 5) Remove filler cap.
- 6) Disconnect battery ground terminal.

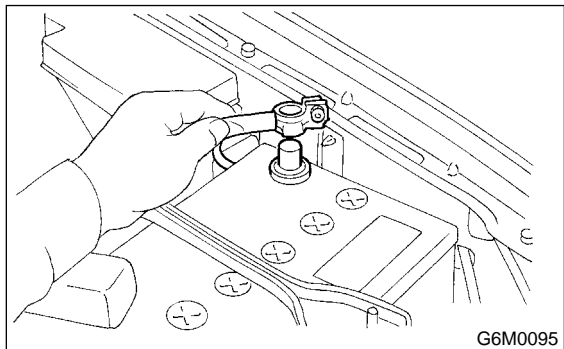

7) Remove air intake duct, air cleaner case and air intake chamber.

<Ref. to IN(H6)-7, REMOVAL, Air Intake Duct.>, <Ref. to IN(H6)-6, REMOVAL, Air Intake Chamber.> and <Ref. to IN(H6)-5, REMOVAL, Air Cleaner.>

- 8) Lift up the vehicle.
- 9) Remove under cover.
- 10) Remove radiator from vehicle. <Ref. to CO(H6)-23, REMOVAL, Radiator.>
- 11) Remove V-belt. <Ref. to ME(H6)-31, REMOVAL, V-belt.>
- 12) Disconnect A/C pressure hoses from A/C compressor. <Ref. to AC-37, REMOVAL, Flexible Hose.>

13) Disconnect the following connectors and cables.

(1) Engine ground terminal

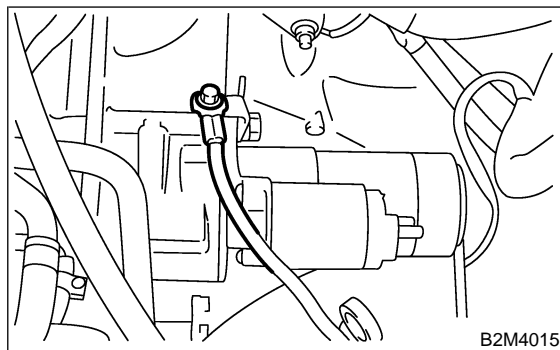

(2) Engine harness connectors

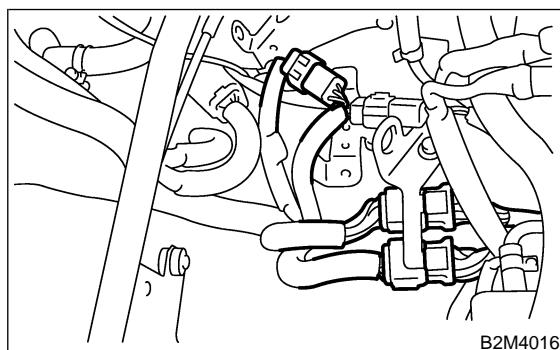

(3) Generator connector, terminal and A/C compressor connector



- (A) A/C compressor connector
(B) Generator connector and terminal

(4) Accelerator cable

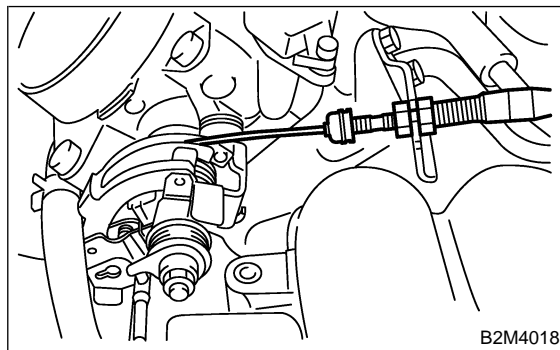

14) Disconnect the following hoses.

(1) Brake booster vacuum hose

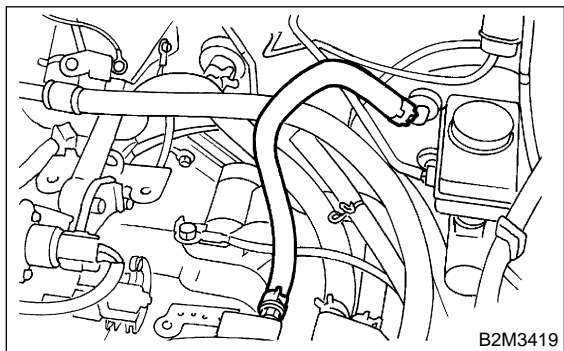

(2) Heater inlet outlet hose

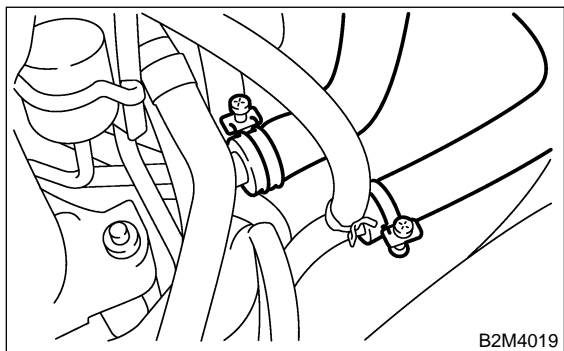

15) Remove power steering pump from bracket.

(1) Remove pipe with bracket.

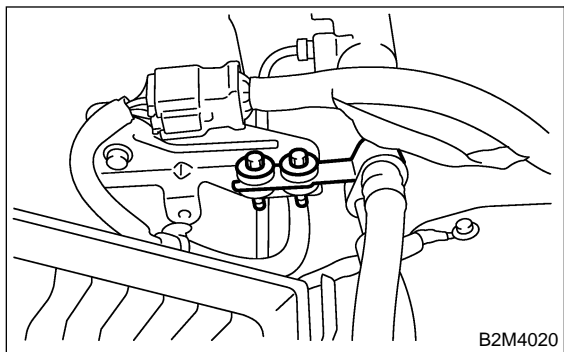

(2) Remove bolts which install power steering pump bracket.

CAUTION:

Do not separate the hose and the pipe from the pump body.

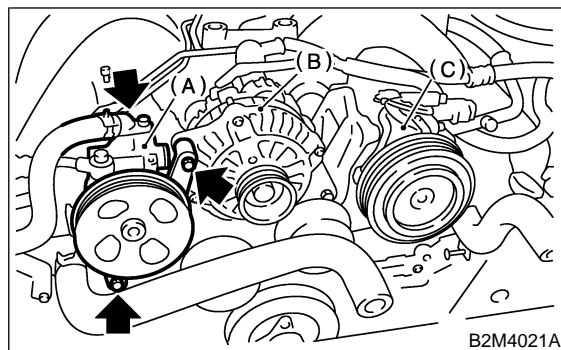

(A) Power steering pump
(B) Generator
(C) A/C compressor

(3) Remove power steering tank from the bracket by pulling it upward.

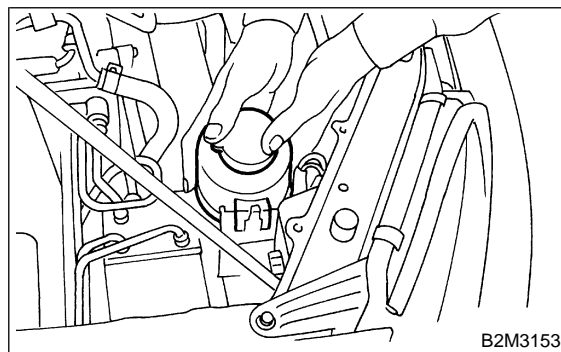

(4) Place power steering pump on the right side wheel apron.

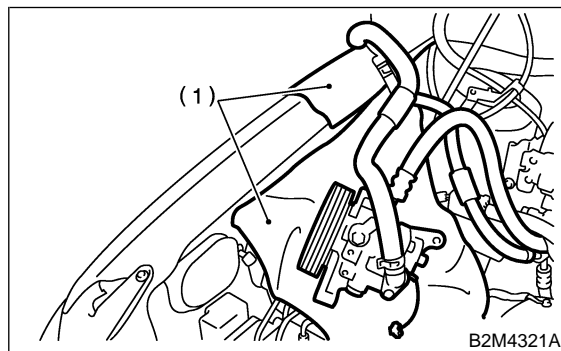

(1) Cloth

16) Remove front exhaust pipe.
<Ref. to EX(H6)-5, REMOVAL, Front Exhaust Pipe.>

ENGINE ASSEMBLY

Mechanical

17) Remove nuts which hold lower side of transmission to engine.

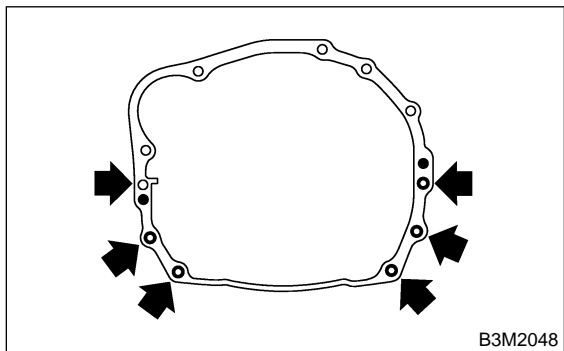

18) Remove nuts which install front cushion rubber onto front crossmember.

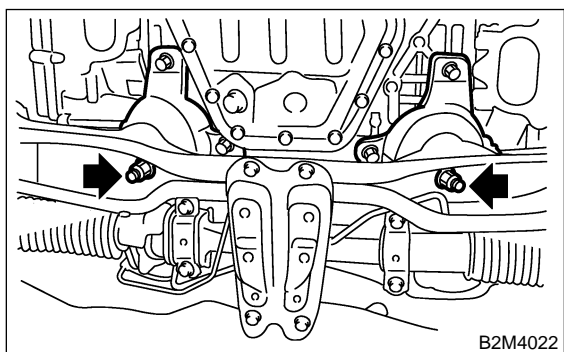

19) Separate torque converter clutch from drive plate.

- (1) Lower the vehicle.
- (2) Remove service hole plug (A).
- (3) Remove bolts which hold torque converter clutch to drive plate.
- (4) Remove other bolts while rotating the engine using ST.

ST 499977100 CRANK PULLEY WRENCH

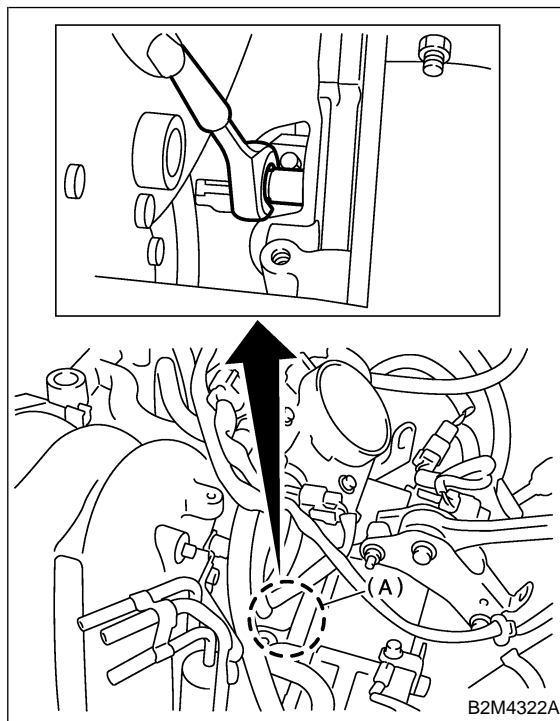

20) Remove pitching stopper.

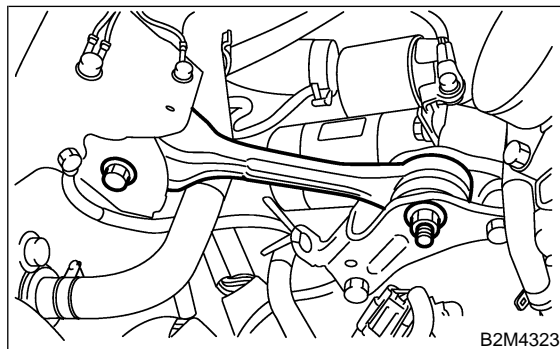

21) Disconnect fuel delivery hose, return hose and evaporation hose.

CAUTION:

- Disconnect hose with its end wrapped with cloth to prevent fuel from splashing.
- Catch fuel from hose into container.

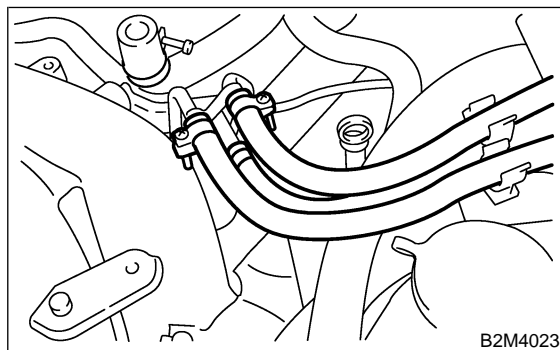

22) Support engine with a lifting device and wire ropes.

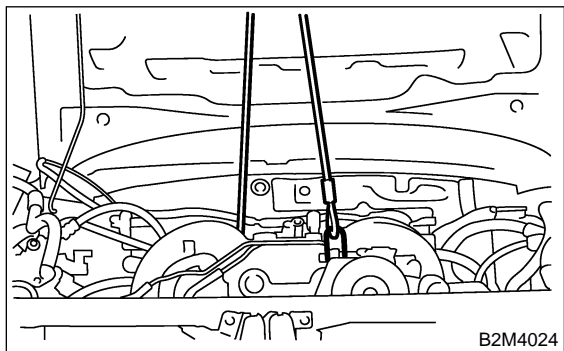

23) Support transmission with a garage jack.

CAUTION:

Before moving engine away from transmission, check to be sure no work has been overlooked. Doing this is very important in order to facilitate re-installation and because transmission lowers under its own weight.

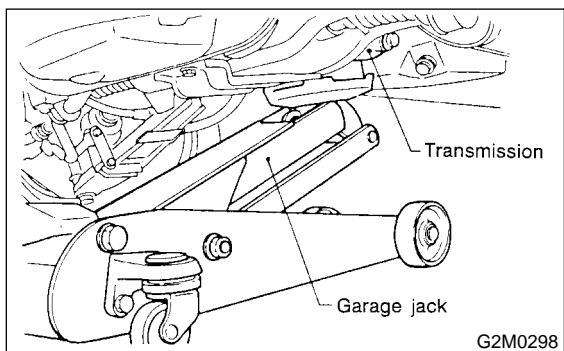

24) Separation of engine and transmission.

- (1) Remove starter. <Ref. to SC(H6)-6, REMOVAL, Starter.>
- (2) Remove bolts which hold upper side of transmission to engine.

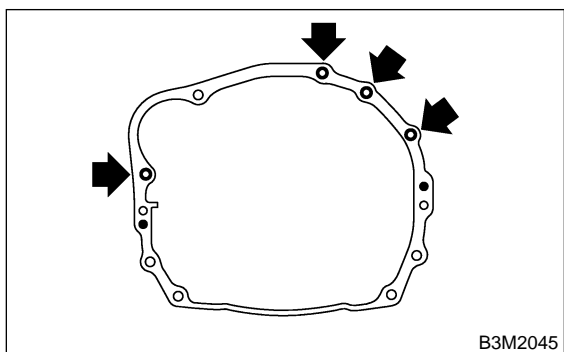

25) Install ST to torque converter clutch case. (AT model)

ST 498277200 STOPPER SET

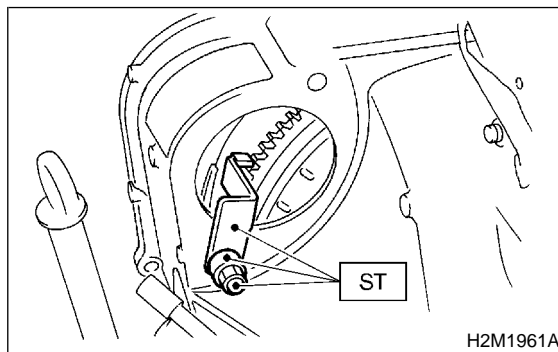

26) Remove engine from vehicle.

- (1) Slightly raise engine.
- (2) Raise transmission with garage jack.
- (3) Move engine horizontally until main shaft is withdrawn from clutch cover.
- (4) Slowly move engine away from engine compartment.

CAUTION:

Be careful not to damage adjacent parts or body panels with crank pulley, oil level gauge, etc.

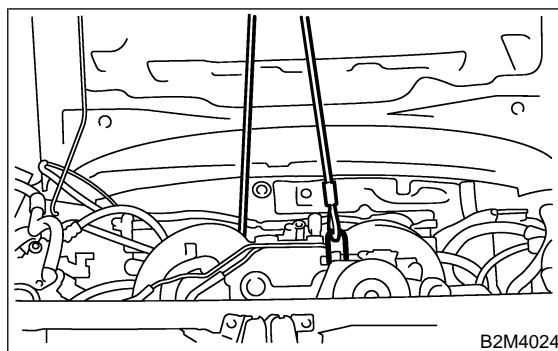

27) Remove front cushion rubbers.

B: INSTALLATION

S143079A11

- 1) Install front cushion rubbers.

Tightening torque:

34 N·m (3.5 kgf-m, 25.3 ft-lb)

- 2) Position engine in engine compartment and align it with transmission.

ENGINE ASSEMBLY

Mechanical

CAUTION:

Be careful not to damage adjacent parts or body panels with crank pulley, oil level gauge, etc.

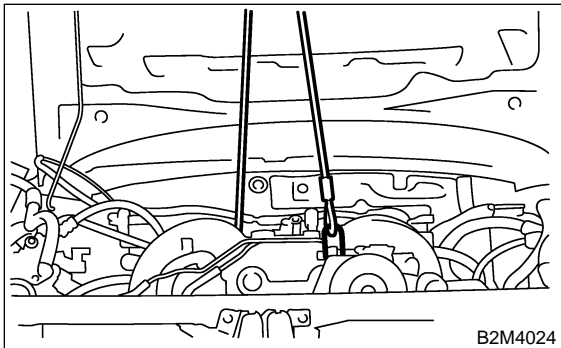

- 3) Tighten bolts which hold upper side of transmission to engine.

Tightening torque:

50 N·m (5.1 kgf-m, 36.9 ft-lb)

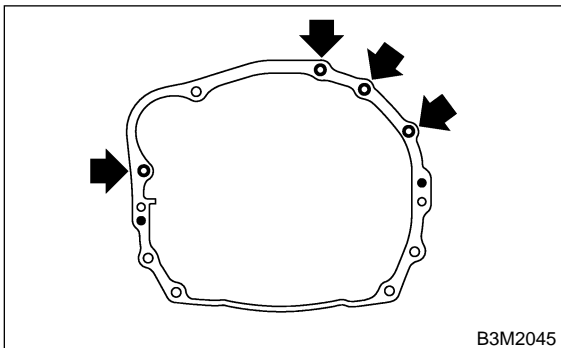

- 4) Remove lifting device and wire ropes.

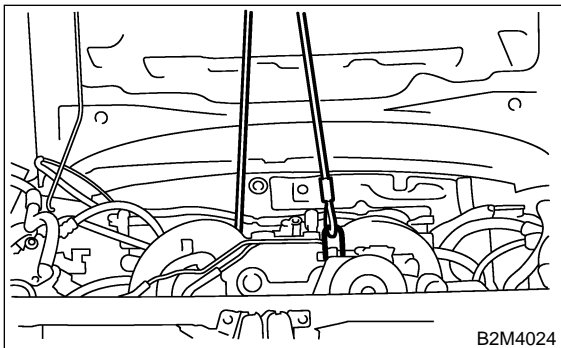

- 5) Remove garage jack.

- 6) Install pitching stopper.

Tightening torque:

T1: 49 N·m (5.0 kgf-m, 36.2 ft-lb)

T2: 57 N·m (5.8 kgf-m, 42 ft-lb)

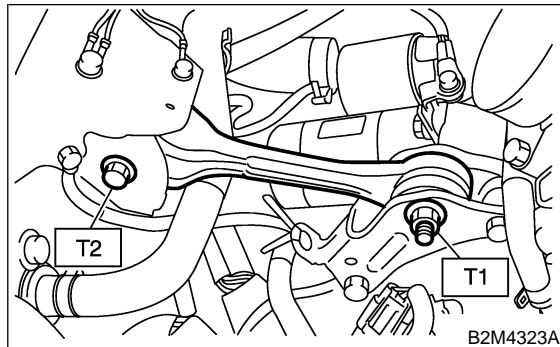

- 7) Remove ST from torque converter clutch case.

NOTE:

Be careful not to drop the ST into the torque converter clutch case when removing ST.

ST 498277200 STOPPER SET

- 8) Install starter. <Ref. to SC(H6)-6, INSTALLATION, Starter.>

- 9) Install torque converter clutch onto drive plate.
(1) Tighten bolts which hold torque converter clutch to drive plate.
(2) Tighten other bolts while rotating the engine by using ST.

CAUTION:

Be careful not to drop bolts into torque converter clutch housing.

ST 499977100 CRANK PULLEY WRENCH

Tightening torque:
25 N·m (2.5 kgf-m, 18.1 ft-lb)

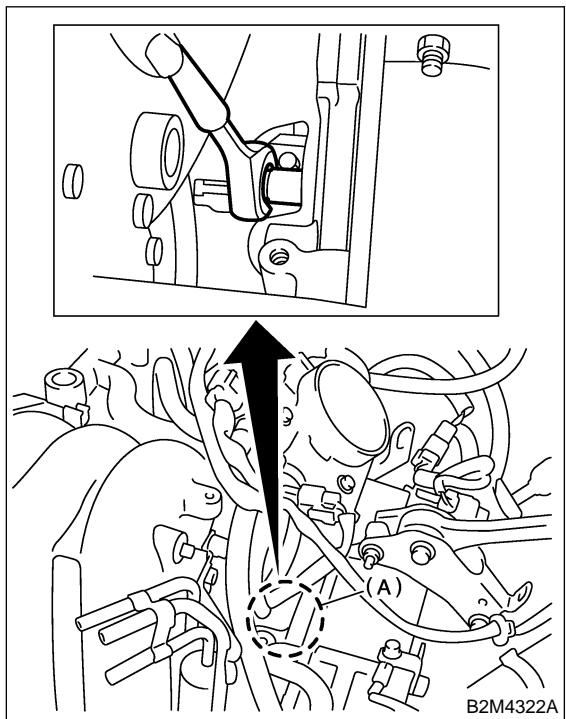

- (3) Clog plug (A) onto service hole.
- 10) Install power steering pump on bracket.
- (1) Install power steering tank on bracket.

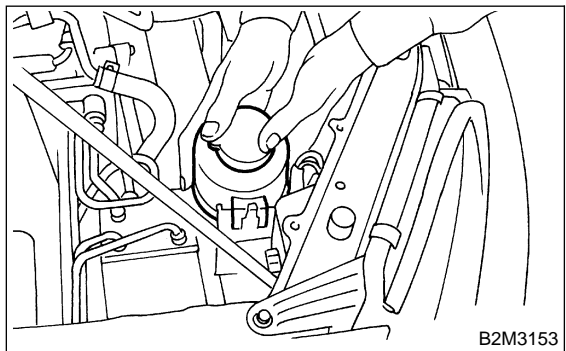

- (2) Install power steering pump on bracket, and tighten bolts.

Tightening torque:
20.1 N·m (2.05 kgf-m, 14.8 ft-lb)

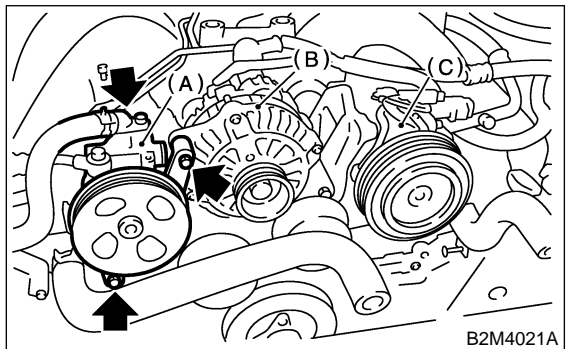

- (3) Tighten bolt which installs power steering pipe bracket.

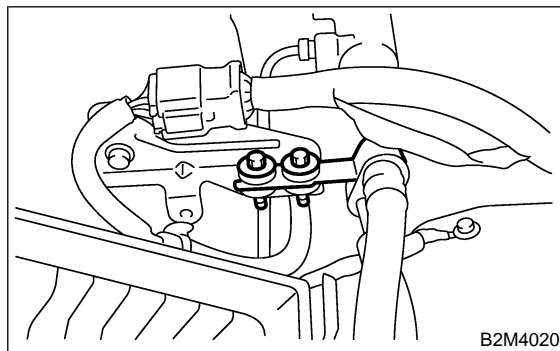

- 11) Tighten nuts which hold lower side of transmission to engine.

Tightening torque:
50 N·m (5.1 kgf-m, 36.9 ft-lb)

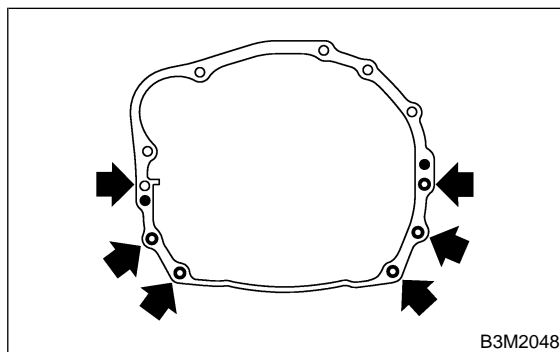

- 12) Tighten nuts which install front cushion rubber onto crossmember.

Tightening torque:
74 N·m (7.5 kgf-m, 54 ft-lb)

CAUTION:
Make sure the front cushion rubber mounting bolts (A) and locator (B) are securely installed.

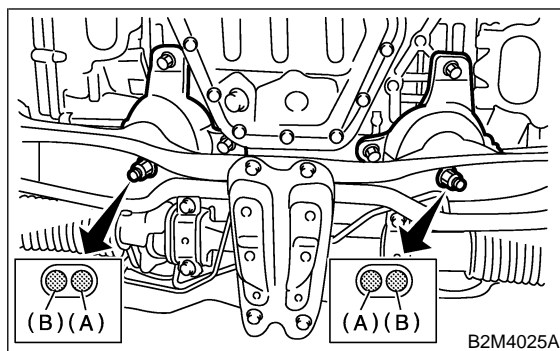

- 13) Install front exhaust pipe.
 <Ref. to EX(H6)-6, INSTALLATION, Front Exhaust Pipe.>
- 14) Connect the following hoses.

ENGINE ASSEMBLY

Mechanical

- (1) Fuel delivery hose, return hose and evaporation hose

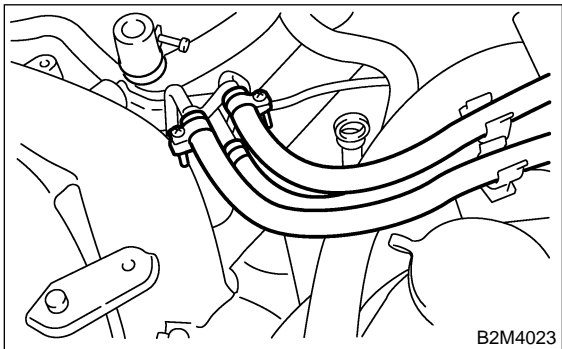

- (2) Heater inlet and outlet hoses

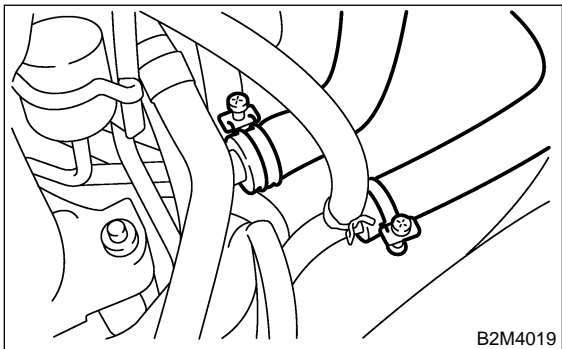

- (3) Brake booster vacuum hose

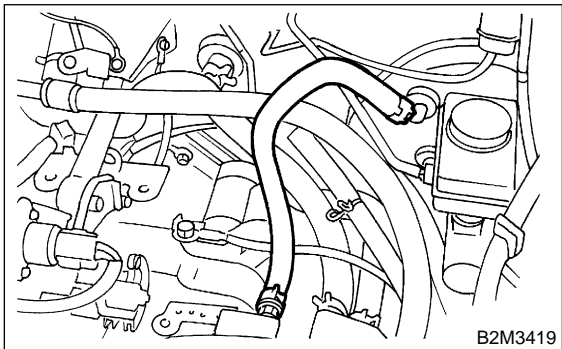

- 15) Connect the following connectors.

- (1) Engine ground terminals

Tightening torque:

14 N·m (1.4 kgf-m, 10.1 ft-lb)

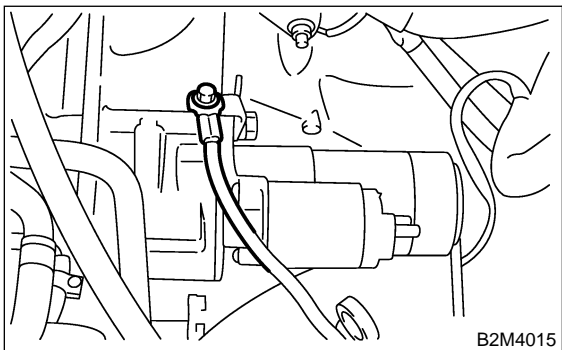

- (2) Engine harness connectors

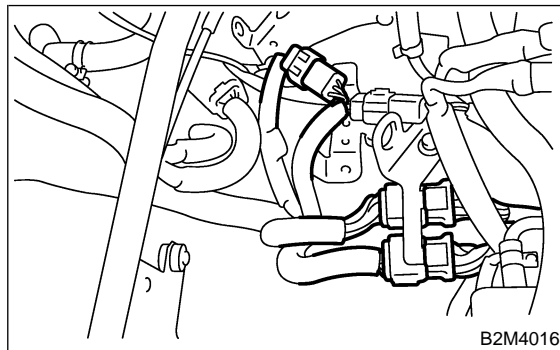

- (3) Alternator connector and terminal (A)
(4) A/C compressor connectors (B)



- 16) Connect the following cables.

- (1)
Accelerator cable

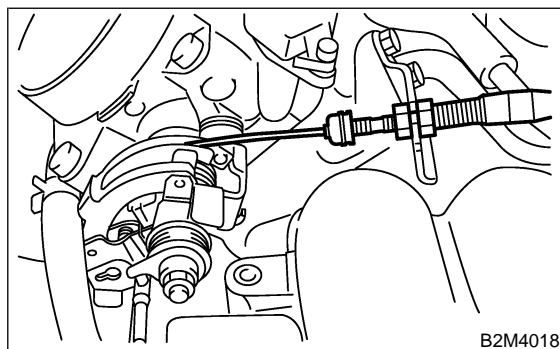

CAUTION:

After connecting each cable, adjust them.

- 17) Install A/C pressure hoses.
<Ref. to AC-37, INSTALLATION, Flexible Hose.>
18) Install V-belt.
19) Install radiator to vehicle. <Ref. to CO(H6)-24, INSTALLATION, Radiator.>
20) Install air intake duct, cleaner case and air intake chamber.
<Ref. to IN(H6)-2, General Description.>
21) Install under cover.
22) Install battery in the vehicle, and connect cables.
23) Fill coolant.

<Ref. to CO(H6)-18, FILLING OF ENGINE COOLANT, REPLACEMENT, Engine Coolant.>

24) Check ATF level and correct if necessary.

<Ref. to AT-9, Automatic Transmission Fluid.>

25) Charge A/C system with refrigerant.

<Ref. to AC-19, OPERATION, Refrigerant Charging Procedure.>

26) Remove front hood stay, and close front hood.

27) Take off the vehicle from lift arms.

C: INSPECTION S143079A10

1) Make sure pipes and hoses are installed correctly.

2) Make sure the engine coolant and ATF are at specified levels.