

CRANKSHAFT PULLEY

Mechanical

10. Crankshaft Pulley S143098

A: REMOVAL S143098A18

- 1) Remove crankshaft pulley cover.

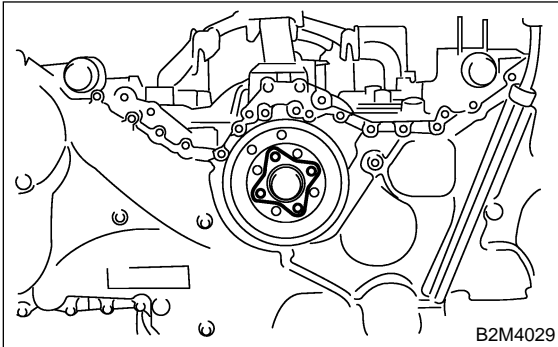

- 2) Remove crankshaft pulley bolt. To lock crankshaft, use ST.

ST 49997100 CRANKSHAFT PULLEY WRENCH

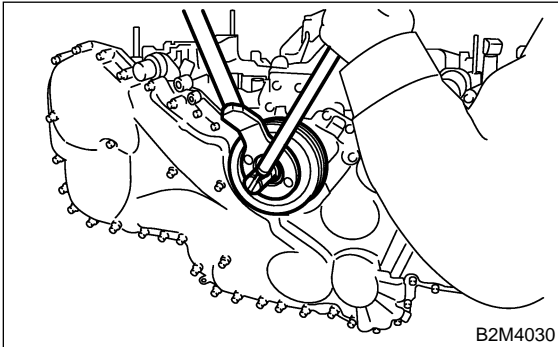

- 3) Remove crankshaft pulley.

B: INSTALLATION S143098A11

- 1) Install crankshaft pulley.
- 2) Install crankshaft pulley bolt. To lock crankshaft, use ST.

ST 49997100 CRANKSHAFT PULLEY WRENCH

- (1) Clean the crankshaft pulley thread using an air gun.
- (2) Apply engine oil to the crankshaft pulley bolt seat and thread.
- (3) Tighten the crankshaft pulley bolts.

Tightening torque:
178 N·m (18.1 kgf·m, 131 ft·lb)

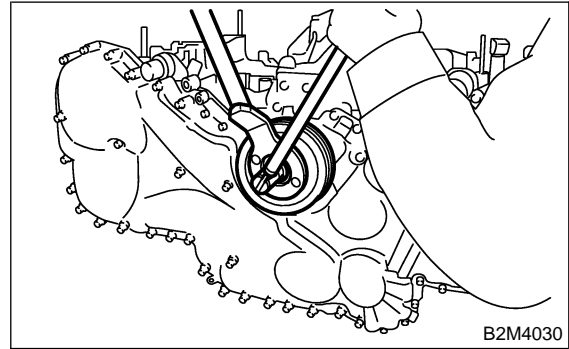

- 3) Install the crankshaft pulley cover.

Tightening torque:
6.4 N·m (0.65 kgf·m, 4.7 ft·lb)

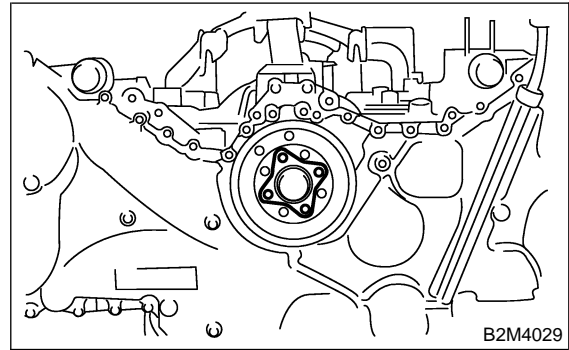

C: INSPECTION S143098A10

- 1) Check crankshaft pulley cover for oil leaks and bleeding.
- 2) Check crankshaft pulley for looseness.