

11. Front Chain Cover S143739

A: REMOVAL S143739A18

- 1) Remove crankshaft pulley. <Ref. to ME(H6)-42, REMOVAL, Crankshaft Pulley.>
- 2) Remove front chain cover.

NOTE:

There are four different types of chain cover mounting bolts. Sort them into separate containers to avoid confusion at installation.

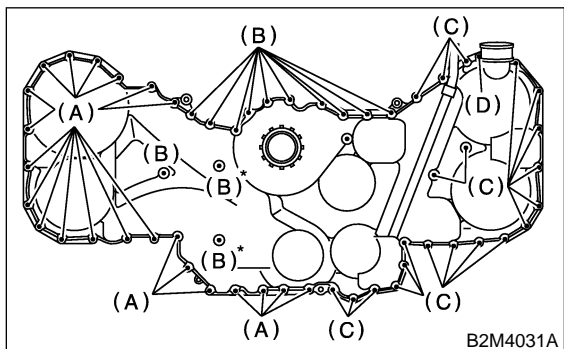

Bolt dimension:

- (A) 6 × 45
- (B) 6 × 16
- (C) 6 × 30
- (D) 6 × 50

*: Sealing washer

B: INSTALLATION S143739A11

- 1) Remove old fluid packing on the matching surface, and degrease it.
- 2) Apply fluid packing to the mating surface of front chain cover.

Fluid packing:

THREE BOND 1280B

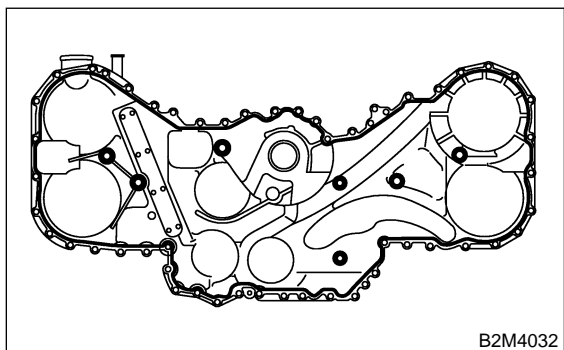

- 3) Install front chain cover. Temporarily tighten the bolts.

CAUTION:

Do not confuse the mounting positions of the bolts.

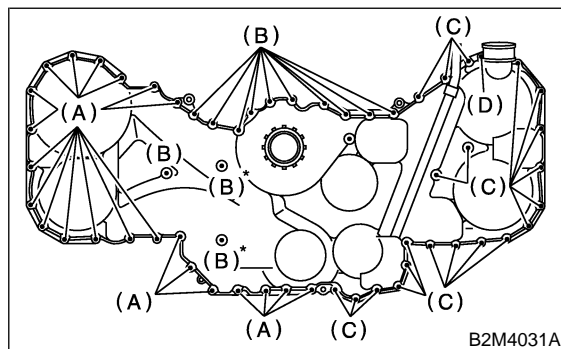

Bolt dimension:

- (A) 6 × 45
- (B) 6 × 16
- (C) 6 × 30
- (D) 6 × 50

*: Sealing washer

FRONT CHAIN COVER

Mechanical

4) Tighten the bolts in the numerical sequence shown in figure.

Tightening torque:

6.6 N·m (0.67 kgf·m, 4.8 ft·lb)

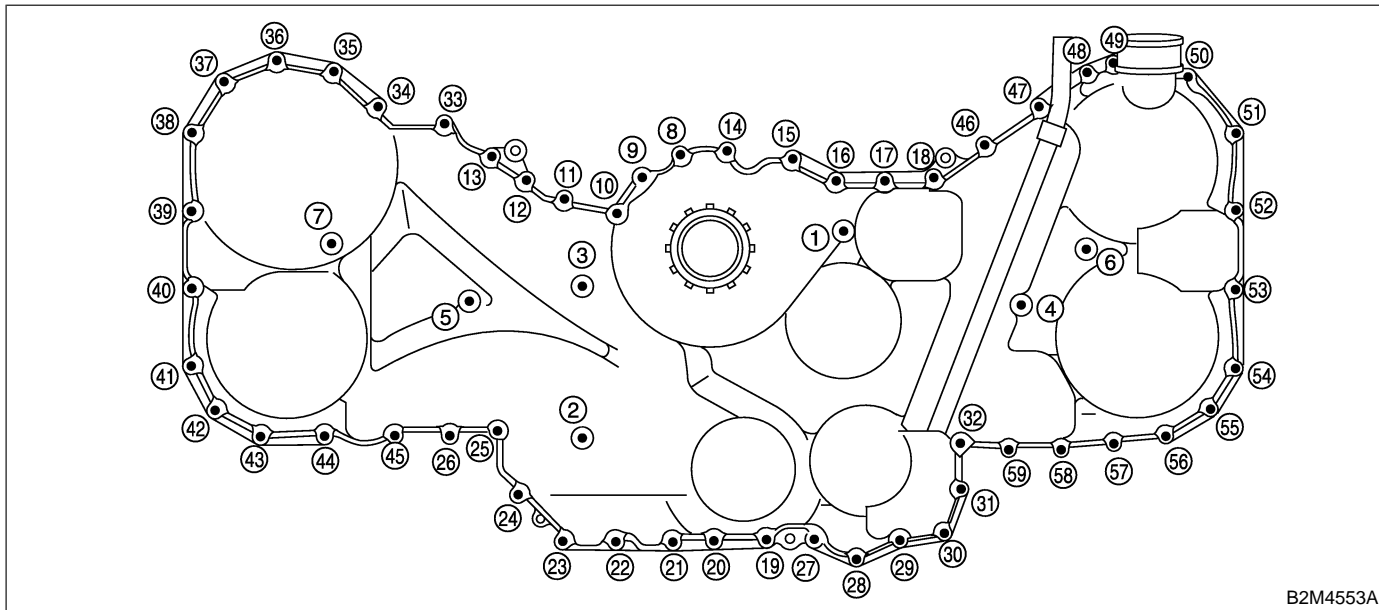

B2M4553A

5) Install crankshaft pulley. <Ref. to ME(H6)-42, INSTALLATION, Crankshaft Pulley.>

C: INSPECTION S143739A10

Check the cover surface for flaws and dents.
Check the cover mating surface and the mounting point of crankshaft pulley for oil leaks.