

## 14. Crankshaft Sprocket S143101

### A: REMOVAL S143101A18

- 1) Remove crankshaft pulley. <Ref. to ME(H6)-42, REMOVAL, Crankshaft Pulley.>
- 2) Remove front chain cover. <Ref. to ME(H6)-43, REMOVAL, Front Chain Cover.>
- 3) Remove timing chain assembly. <Ref. to ME(H6)-45, REMOVAL, Timing Chain Assembly.>
- 4) Remove camshaft sprocket. <Ref. to ME(H6)-50, REMOVAL, Camshaft Sprocket.>
- 5) Remove crankshaft sprocket (A).

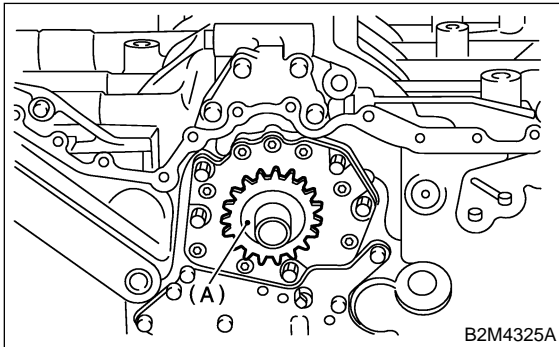

### B: INSTALLATION S143101A11

- 1) Install crankshaft sprocket (A).

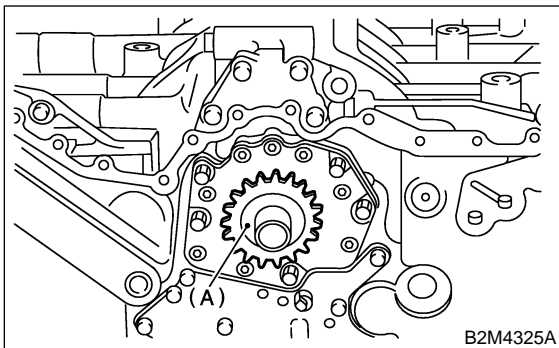

- 2) Install camshaft sprocket. <Ref. to ME(H6)-50, INSTALLATION, Camshaft Sprocket.>
- 3) Install timing chain assembly. <Ref. to ME(H6)-46, INSTALLATION, Timing Belt Assembly.>
- 4) Install front chain cover. <Ref. to ME(H6)-43, INSTALLATION, Front Chain Cover.>
- 5) Install crankshaft pulley. <Ref. to ME(H6)-42, INSTALLATION, Crankshaft Pulley.>

### C: INSPECTION S143101A10

- 1) Check sprocket teeth for abnormal wear and scratches.
- 2) Make sure there is no free play between sprocket and key.
- 3) Check crankshaft sprocket notch for sensor for damage and contamination of foreign matter.