

10. Fuel Filter SA07027

A: REPLACEMENT SA07027A20

WARNING:

- Place “No fire” signs near the working area.
- Disconnect ground cable from battery.

CAUTION:

Be careful not to spill fuel on the floor.

1) Before removing the hose, filter, pump, etc., be sure to release the fuel pressure, as follows:

- Disconnect the wiring connector of the fuel pump.
- Crank the engine for more than five seconds. If the engine starts, let the engine run until it stops.
- After turning IG switch OFF, connect the wiring connector of the fuel pump.
- Disconnect ground cable from battery.

2) Loosen the screw of the hose clamp and pull off the hose from the filter.

3) Remove the filter from the holder.

4) Replace fuel filter with a new one.

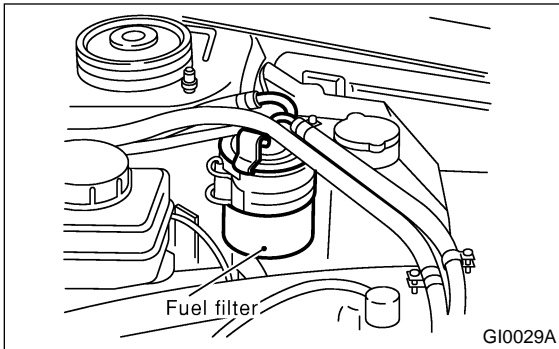

5) Install the hoses as shown in the figure.

Tightening torque:

1.0 — 1.5 N·m (0.1 — 0.15 kgf·m, 0.7 — 1.1 ft·lb)

CAUTION:

- If the hose is damaged at the clamping portion, replace the hose with a new one.
- If the hose clamp is deformed too much, replace with a new one.
- Correct the hose position by removing any twist so that it will not interfere with the filter body or washer tank, before tightening the screw of the hose clamp.

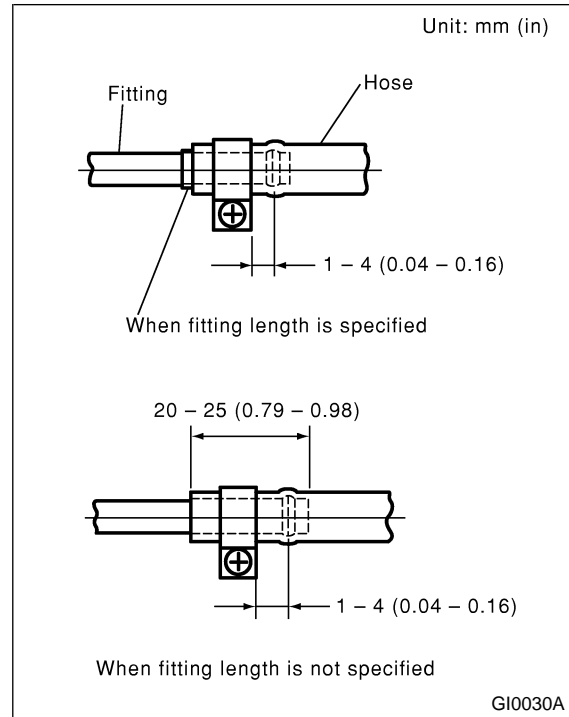

6) Install the fuel filter bracket to the vehicle body. And tighten the bolts to the specified torque.

NOTE:

Make sure that the clamp screw is not loose.

Tightening torque:

7.35 N·m (0.75 kgf·m, 5.45 ft·lb)

