

21. Brake Linings and Drums

SA07696

A: INSPECTION

SA07696A10

1. REAR DRUM BRAKE

SA07696A1001

- 1) Remove brake drum, and check that there is no fluid leakage from wheel cylinder.
If there is fluid leakage from wheel cylinder, replace it. <Ref. to BR-33, Rear Drum Brake Drum.>
- 2) Inspect brake shoes for damage or deformities and check brake linings for wear.

NOTE:

- Always replace both leading and trailing brake shoes for the left and right wheels at the same time.
- When either the left or the right brake assembly is replaced, always replace the leading shoe and trailing shoe of the other.
- The cotter pin, once removed, cannot be reused.

Thickness of lining (except back metal)

Standard value: 4.1 mm (0.161 in)

Service limit: 1.5 mm (0.059 in)

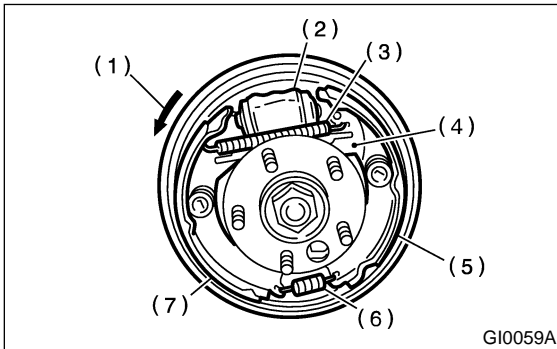

- (1) Rotational direction of drum (Forward)
- (2) Wheel cylinder
- (3) Upper shoe return spring
- (4) Adjusting lever
- (5) Trailing shoe
- (6) Lower shoe return spring
- (7) Leading shoe

To replace trailing shoe, remove cotter pin. Clevis pin should also be replaced if worn.

- 3) Check brake drum for wear, dents or other damage.

If the inside surface of brake drum is streaked, correct the surface with emery cloth (#200 or more). If it is unevenly worn, tapered, or the outside surface of brake drum is damaged, correct or replace it.

Brake drum inner diameter

Standard value: 228.6 mm (9.000 in)

Service limit: 230.6 mm (9.079 in)

If deformation or wear of back plate, shoe, etc. is noticeable, replace the affected parts.

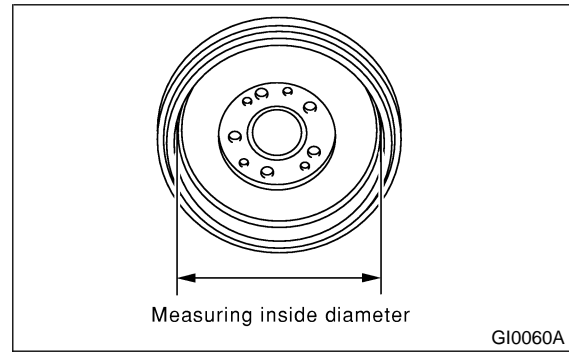

2. PARKING BRAKE (REAR DISC BRAKE)

SA07696A1002

Inspect brake linings and drums of both sides of the rear brake at the same time by removing brake drums.

- 1) Inspect brake shoes for damage or deformation and check brake linings for wear.

NOTE:

Always replace both primary and secondary brake shoes for the left and right wheels at the same time.

Brake lining thickness excluding back metal

Standard value: 3.2 mm (0.126 in)

Wear limit: 1.5 mm (0.059 in)

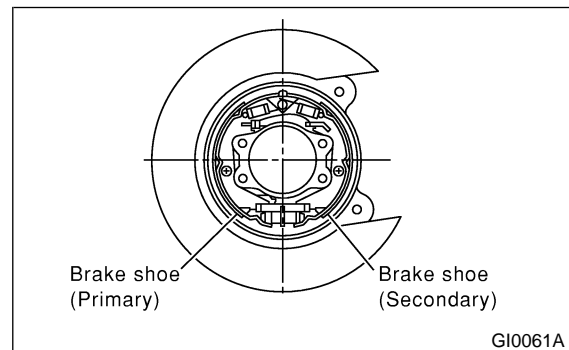

2) Check brake drum for wear, dents or other damage. If the inside surface of brake drum is streaked, correct the surface with emery cloth (#200 or more). If it is unevenly worn, tapered, or the outside surface of brake drum is damaged, correct or replace it.

Brake drum inside diameter

Standard value: 170 mm (6.69 in)

Wear limit: 171 mm (6.73 in)

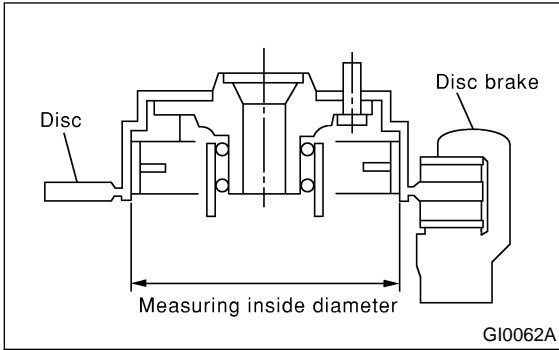

- 3) If the deformation or wear of back plate, shoe, etc. is noticeable, replace them.
- 4) When the shoe return spring tension is excessively weakened, replace it, taking care to identify upper and lower springs.

B: ADJUSTMENT

SA07696A01

1. REAR DRUM BRAKE

SA07696A0101

The main brake is adjusted automatically, and so there is no need to adjust it.

2. PARKING BRAKE (REAR DISC BRAKE)

SA07696A0102

For rear disc brake, adjust parking brake after bleeding the air.

- 1) Remove rear cover (rubber) installed at back plate.
- 2) Turn adjuster toward arrow mark (upward) until it is locked slightly, by using slot-type screwdriver as shown in illustration.

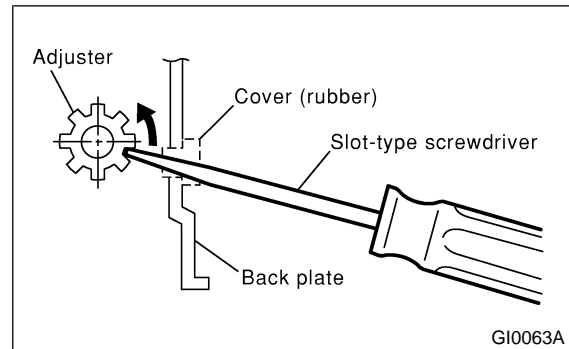

- 3) Turn back (downward) adjuster 3 to 4 notches.
- 4) Install cover (rubber) at original position correctly.