

MASTER CYLINDER

Clutch System

6. Master Cylinder S504168

A: REMOVAL S504168A18

- 1) Thoroughly drain brake fluid from reservoir tank.
- 2) Remove snap pin, clevis pin and separate push rod of master cylinder from clutch pedal.

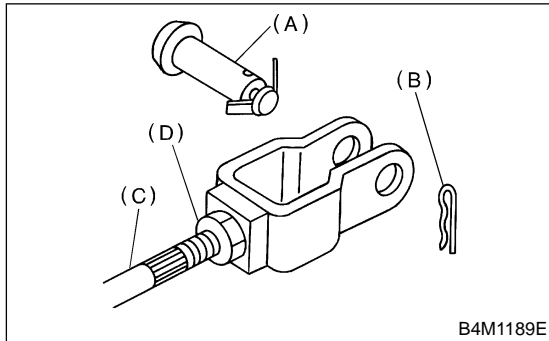

- (A) Clevis pin
- (B) Snap pin
- (C) Push rod
- (D) Lock nut

- 3) Remove air cleaner case and air intake duct.
- 4) Remove clutch pipe from master cylinder.
- 5) Remove master cylinder with reservoir tank.

CAUTION:

Be extremely careful not to spill brake fluid. Brake fluid spilt on the vehicle body will harm the paint surface; wipe it off quickly if spilt.

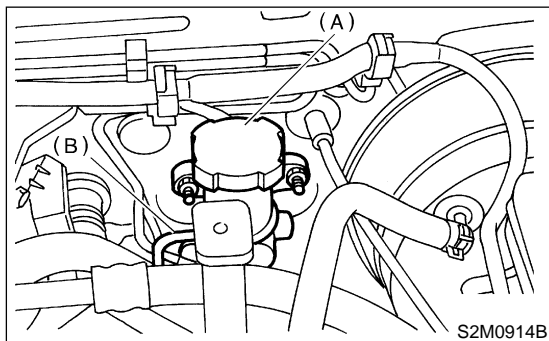

- (A) Master cylinder
- (B) Clutch pipe

B: INSTALLATION S504168A11

- 1) Install master cylinder to body, and install clutch pipe to master cylinder.

CAUTION:

Check that pipe is routed properly.

Tightening torque:

T1: 15 N·m (1.5 kgf-m, 10.8 ft-lb)

T2: 18 N·m (1.8 kgf-m, 13.0 ft-lb)

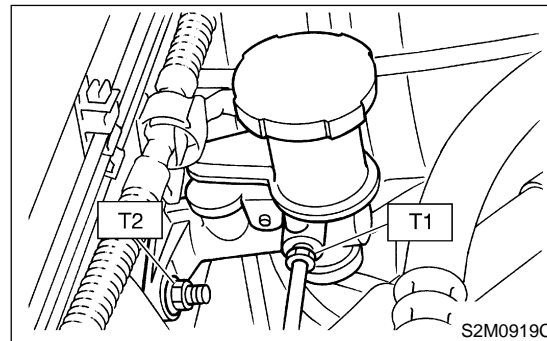

- 2) Connect push rod of master cylinder to clutch pedal, and install clevis pin and snap pin.

NOTE:

Apply grease to clevis pin.

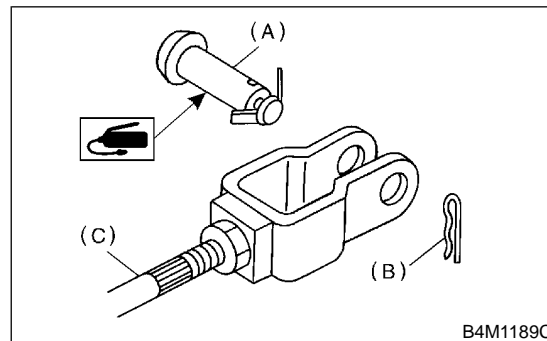

- (A) Clevis pin
- (B) Snap pin
- (C) Push rod

- 3) After bleeding air from system, ensure that clutch operates properly.
<Ref. to CL-20 Clutch Fluid Air Bleeding.>
- 4) Install air cleaner case and air intake duct.

C: DISASSEMBLY

S504168A06

1) Remove straight pin and reservoir tank.

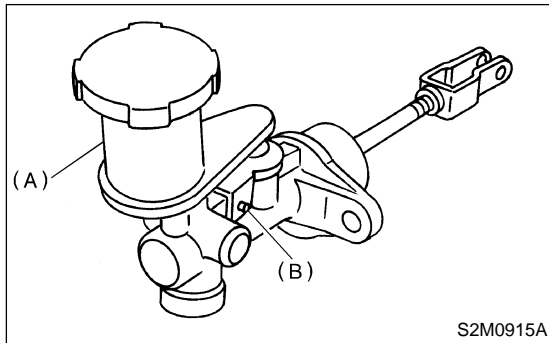

- (A) Reservoir tank
- (B) Straight pin

2) Remove oil seal.

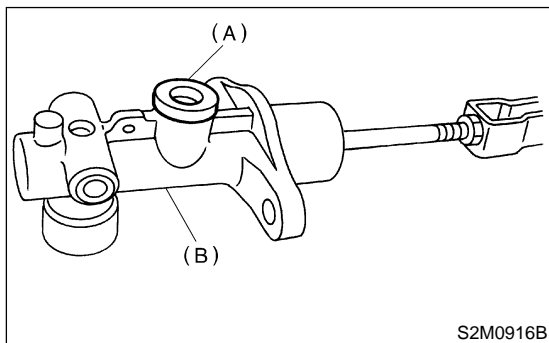

- (A) Oil seal
- (B) Master cylinder

3) Move the cylinder boot backward.

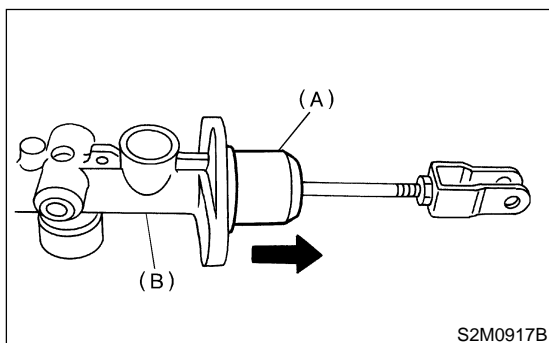

- (A) Cylinder boot
- (B) Master cylinder

4) Remove snap ring.

CAUTION:

Be careful when removing the snap ring to prevent the rod, washer, piston and return spring from flying out.

D: ASSEMBLY

S504168A02

1) Apply a coat of grease to the contacting surfaces of the push rod and piston before installation.

Grease:

SILICONE GREASE G40M (Part No. 004404003)

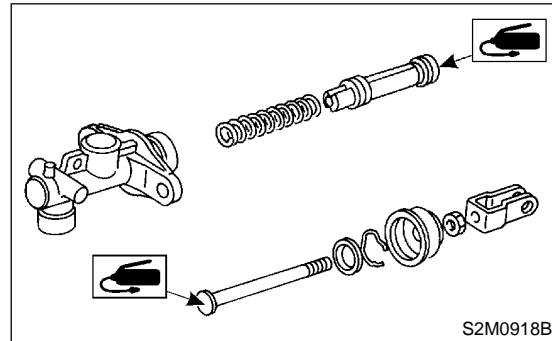

2) To assemble the master cylinder reverse the sequence of disassembly procedure.

E: INSPECTION

S504168A10

If any damage, deformation, wear, swelling, rust or other faults are found on the cylinder, piston, push rod, fluid reservoir, return spring and gasket, replace the faulty part.

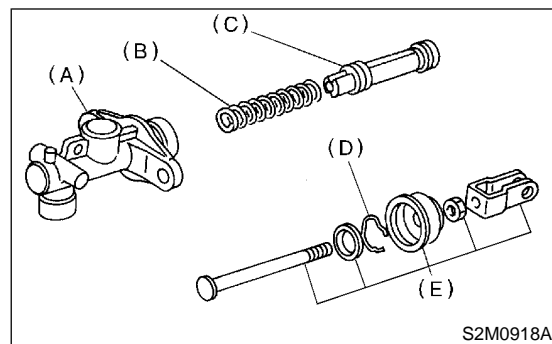

- (A) Master cylinder body
- (B) Return spring
- (C) Piston
- (D) Snap ring
- (E) Rod ASSY