

10. Clutch Pedal

S504256

A: REMOVAL

S504256A18

- 1) Remove steering column. <Ref. to PS-20 REMOVAL, Tilt Steering Column.>
- 2) Disconnect connectors from stop light and clutch switches.
- 3) Remove snap pins which secure lever to push rod and operating rod.
- 4) Remove clevis pins which secure lever to push rod and operating rod.

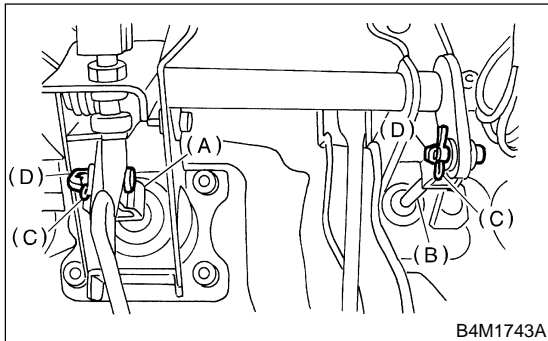

B4M1743A

- (A) Operating rod
- (B) Push rod
- (C) Snap pin
- (D) Clevis pin

- 5) Remove nut which secures clutch master cylinder.

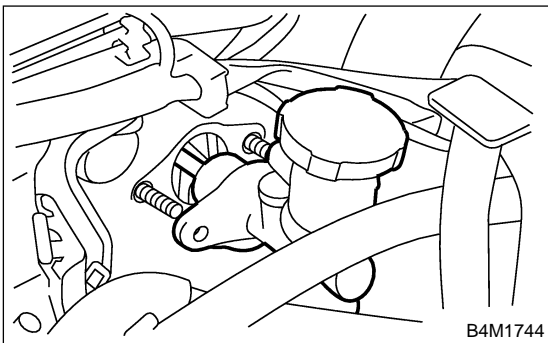

B4M1744

- 6) Remove bolts and nuts which secure brake and clutch pedals, and remove pedal assembly.

B: INSTALLATION

S504256A11

- 1) Install in the reverse order of removal.

CAUTION:

- If cable clamp is damaged, replace it with a new one.
- Never fail to cover outer cable end with boot.
- Be careful not to kink accelerator cable.
- Always use new clevis pins.

- 2) Adjustment of clutch pedal and adjustment after pedal installation. <Ref. to CL-22 ADJUSTMENT, Clutch Pedal.>

C: DISASSEMBLY

S504256A06

- 1) Remove clutch switches.
- 2) Remove clips, assist spring assembly and bush.

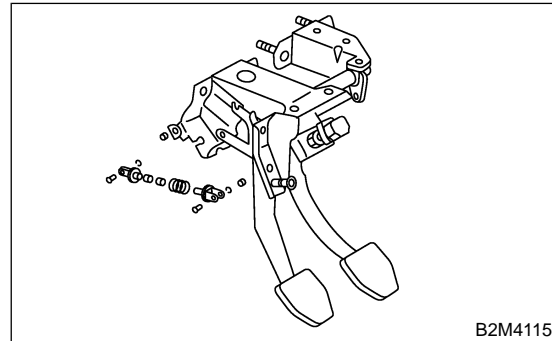

B2M4115

- 3) Remove spring pin and lever.

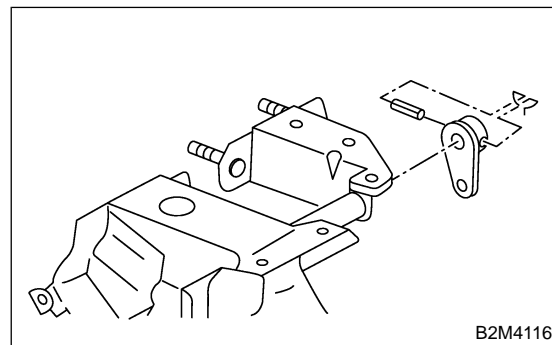

B2M4116

- 4) Remove clutch pedal and bushes.

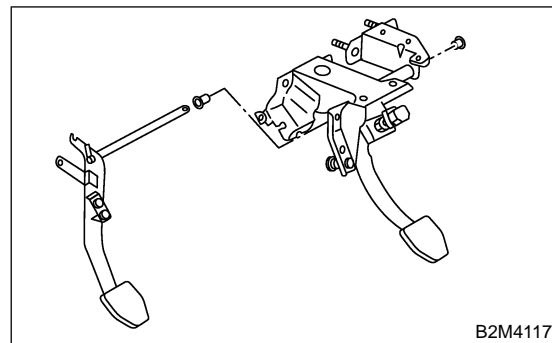

B2M4117

- 5) Remove stopper, clip, O-ring, rod S, and then remove spring and bush S.

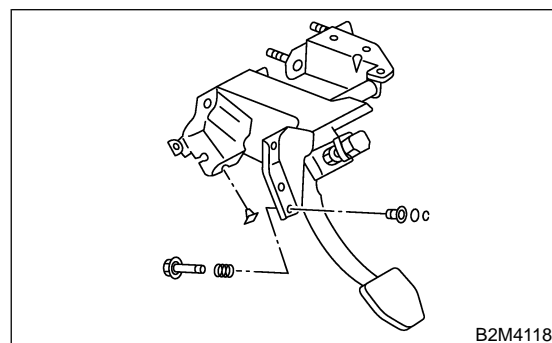

B2M4118

- 6) Remove stoppers from clutch pedal.

CLUTCH PEDAL

Clutch System

7) Remove clutch pedal pad.

D: ASSEMBLY S504256A02

- 1) Attach stop light switch, etc. to pedal bracket temporarily.
- 2) Clean inside of bores of clutch pedal and brake pedal, apply grease, and set bushings into bores.
- 3) Align bores of pedal bracket, clutch pedal and brake pedal, attach brake pedal return spring and clutch pedal effort reducing spring (vehicle with hill holder), and then install pedal bolt.

NOTE:

Clean up inside of bushings and apply grease before installing spacer.

Tightening torque:

T: 29 N·m (3.0 kgf·m, 21.7 ft·lb)

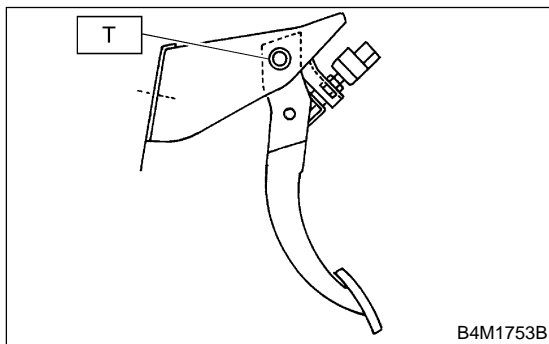

E: INSPECTION S504256A10

1. CLUTCH PEDAL S504256A1001

Move clutch pedal pads in the lateral direction with a force of approximately 10 N (1 kg, 2 lb) to ensure pedal deflection is in specified range.

CAUTION:

If excessive deflection is noted, replace bushings with new ones.

Deflection of clutch pedal:

Service limit

5.0 mm (0.197 in) or less

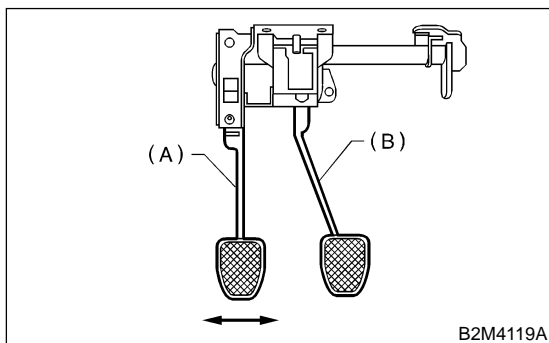

- (A) Clutch pedal
- (B) Brake pedal

F: ADJUSTMENT S504256A01

1. CLUTCH PEDAL S504256A0101

- 1) Turn clutch switch lock nuts until clutch pedal full stroke length is within specifications.

CAUTION:

Do not attempt to turn clutch switch to adjust clutch pedal full stroke length.

NOTE:

If lock nuts cannot adjust clutch pedal full stroke length to specifications, turn master cylinder push rod to adjust it.

Specified clutch pedal full stroke: A
130 — 135 mm (5.12 — 5.31 in)

Tightening torque (Clutch switch lock nut):
T: 8 N·m (0.8 kgf·m, 5.8 ft·lb)

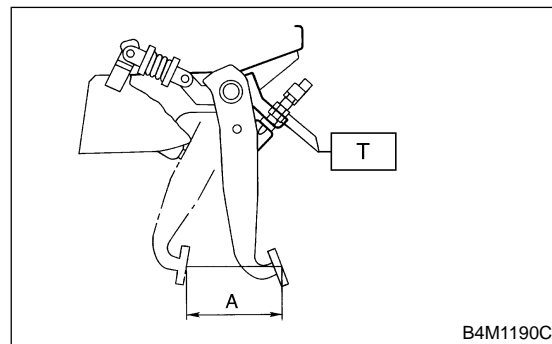

- 2) Turn master cylinder push rod so that clevis pin moves to the left and then to the right. Clevis pin must move without resistance while it is rattling.

Tightening torque (Push rod lock nut):
T: 8 N·m (0.8 kgf·m, 5.8 ft·lb)

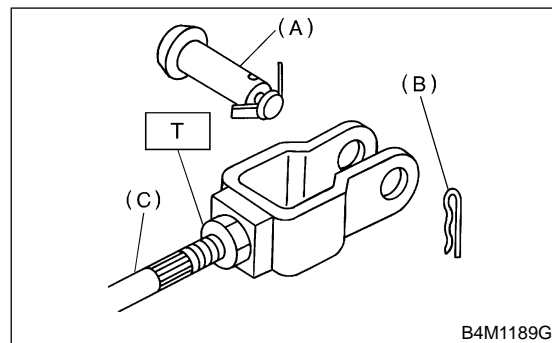

- (A) Clevis pin
- (B) Snap pin
- (C) Push rod
- (D) Lock nut

- 3) Depress and release clutch pedal 2 to 3 times to ensure that clutch pedal and release fork operate smoothly. If clutch pedal and release fork do not operate smoothly, bleed air from clutch hydraulic system. <Ref. to CL-20 Clutch Fluid Air Bleeding.>

4) Measure clutch pedal full stroke length again to ensure that it is within specifications. If it is not, repeat adjustment procedures again from the beginning.

Specified clutch pedal full stroke:
130 — 135 mm (5.12 — 5.31 in)

5) Move clevis pin to the left and then to the right. It should move without resistance while it is rattling. If resistance is felt, repeat adjustment procedures again from the beginning.

6) Push release lever until operating cylinder push rod retracts. Ensure that clutch fluid level in reservoir tank increases. If clutch fluid level increases, hydraulic clutch is properly adjusted; if fluid level does not increase or push rod does not retract, replace master cylinder with new one. <Ref. to CL-16 Master Cylinder.>

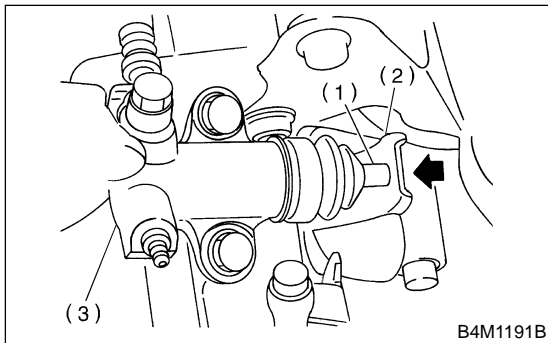

- (1) Push rod
- (2) Release lever
- (3) Operating cylinder

7) Push release fork until operating cylinder push rod retracts. Check that clutch fluid level in reservoir tank increases.

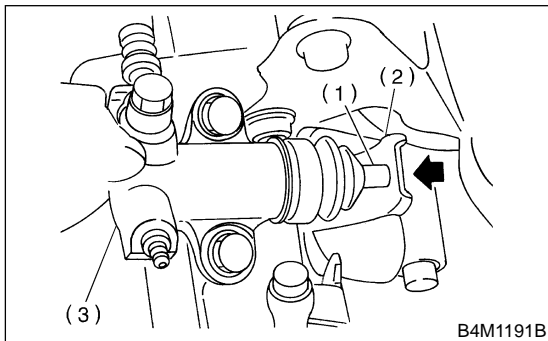

- (1) Push rod
- (2) Release lever
- (3) Operating cylinder

8) If clutch fluid level increases, hydraulic clutch play is correct.

9) If clutch fluid level does not increase or push rod does not retract, clutch pedal must be readjusted.

10) Check the fluid level on the outside of the clutch master cylinder tank. If the level is below "MIN", add clutch fluid to bring it up to "MAX".

Recommended clutch fluid:
FMVSS No. 116, fresh DOT 3 or DOT 4 brake fluid

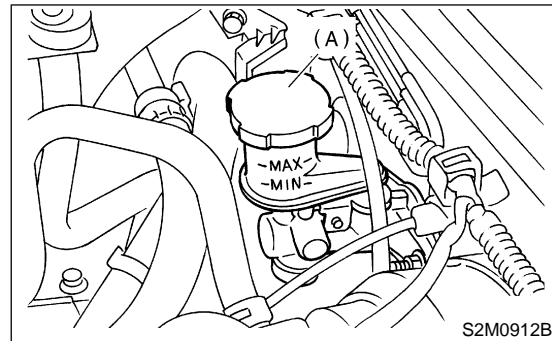

(A) Reservoir tank