

SELECT CABLE

5. Select Cable S501549

A: REMOVAL S501549A18

- 1) Prior to removal, set lever to "N" position.
- 2) Remove under cover.
- 3) Remove rear exhaust pipe and muffler.

CAUTION:

When removing exhaust pipes, be careful each exhaust pipe does not drop out.

- 4) Remove heat shield cover.

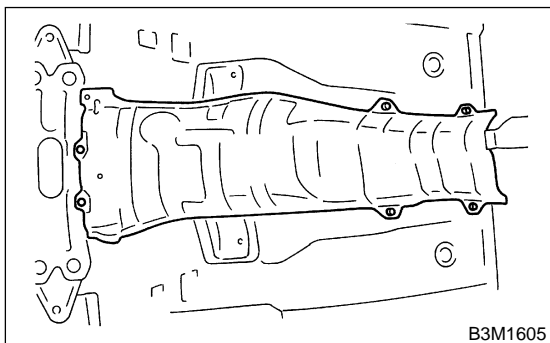

- 5) Remove snap pin from range select lever.

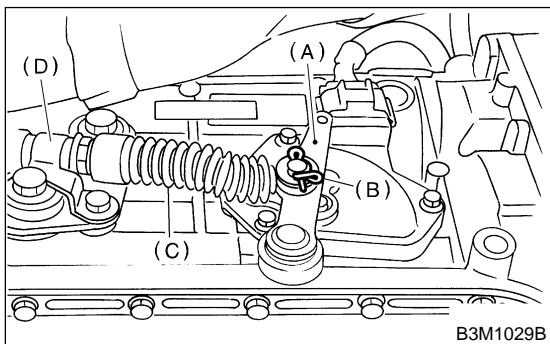

- (A) Range select lever
- (B) Snap pin
- (C) Select cable
- (D) Clamp

- 6) Remove plate assembly from transmission case.

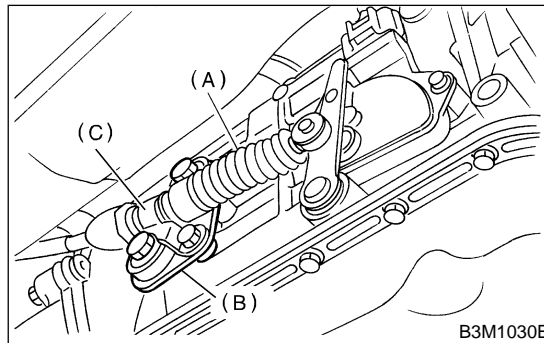

- (A) Select cable
- (B) Plate ASSY
- (C) Clamp

- 7) Disconnect cable from select lever and then remove cable bracket.

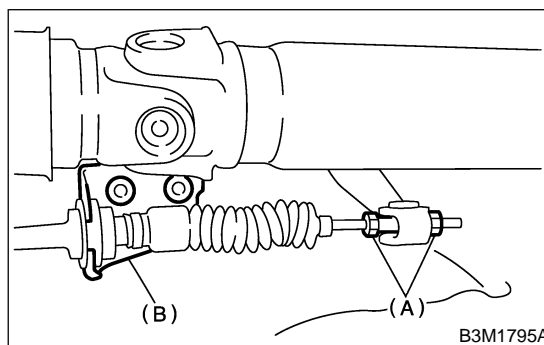

- (A) Adjusting nuts
- (B) Cable bracket

- 8) Remove select cable from plate assembly.

B: INSTALLATION S501549A11

1) Install select cable to plate assembly.

Tightening torque:

32 N·m (3.3 kgf-m, 24 ft-lb)

2) Install select cable to range select lever.

3) Install plate assembly to transmission.

Tightening torque:

T: 24.5 N·m (2.5 kgf-m, 18.1 ft-lb)

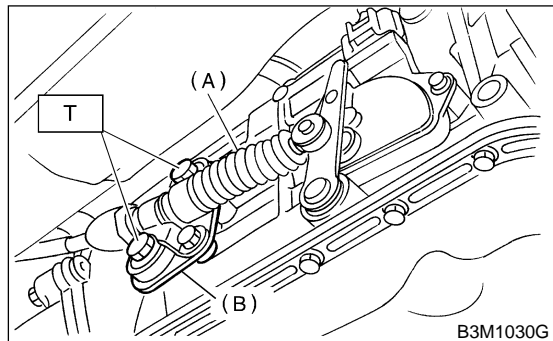

- (A) Select cable
- (B) Plate ASSY

4) Install snap pin to range select lever.

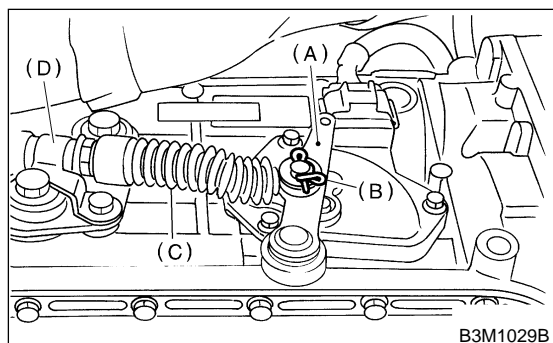

- (A) Range select lever
- (B) Snap pin
- (C) Select cable
- (D) Clamp

5) Move the select lever to the "N" position, then adjust the select cable position. <Ref. to CS-25 ADJUSTMENT, Select Cable.>

6) Install heat shield cover.

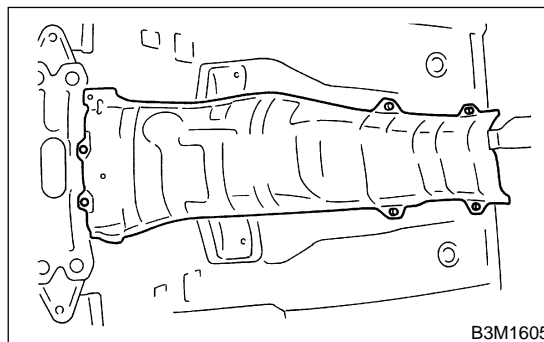

7) Install rear exhaust pipe to muffler.

8) Install under cover.

C: INSPECTION S501549A10

Check the removed cable and replace if damaged, rusty, or malfunctioning.

- 1) Check for smooth operation of the cable.
- 2) Check the inner cable for damage and rust.
- 3) Check the outer cable for damage, bends, and cracks.
- 4) Check the boot for damage, cracks, and deterioration.

D: ADJUSTMENT S501549A01

Move select lever from "P" position to "1" position. You should be able to feel the detentes in each position. If the detentes cannot be felt or the position pointer is improperly aligned, adjust the cable.

- 1) Prior to removal, set lever to "N" position.
- 2) Remove rear exhaust pipe and muffler.
- 3) Remove heat shield cover.

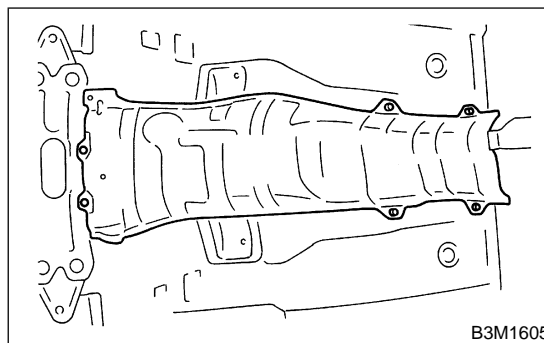

SELECT CABLE

Control Systems

4) Loosen the adjusting nut on each side.

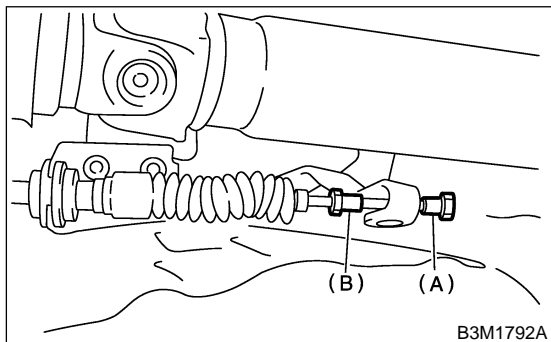

- (A) Adjusting nut A
- (B) Adjusting nut B

7) After completion of fitting, make sure that the select lever operates smoothly all across the operating range.

5) Turn adjusting nut B until it lightly touches the connector.

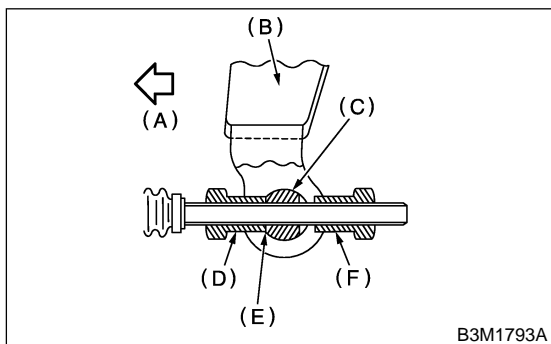

- (A) Front side
- (B) Select lever
- (C) Connector
- (D) Adjusting nut B
- (E) Contact point
- (F) Adjusting nut A

6) While preventing adjusting nut B from moving with a wrench, tighten adjusting nut A.

Tightening torque:

7.5 N·m (0.76 kgf·m, 5.5 ft·lb)

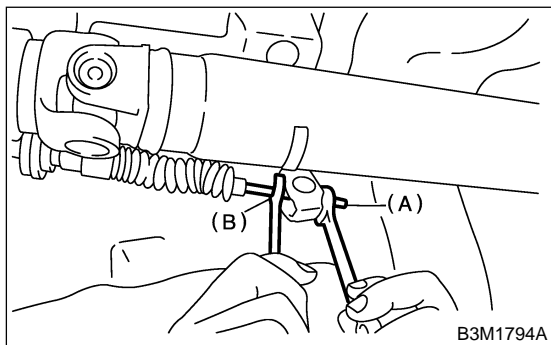

- (A) Adjusting nut A
- (B) Adjusting nut B