

# REVERSE CLUTCH

Automatic Transmission

## 2. Reverse Clutch

### A: CONSTRUCTION

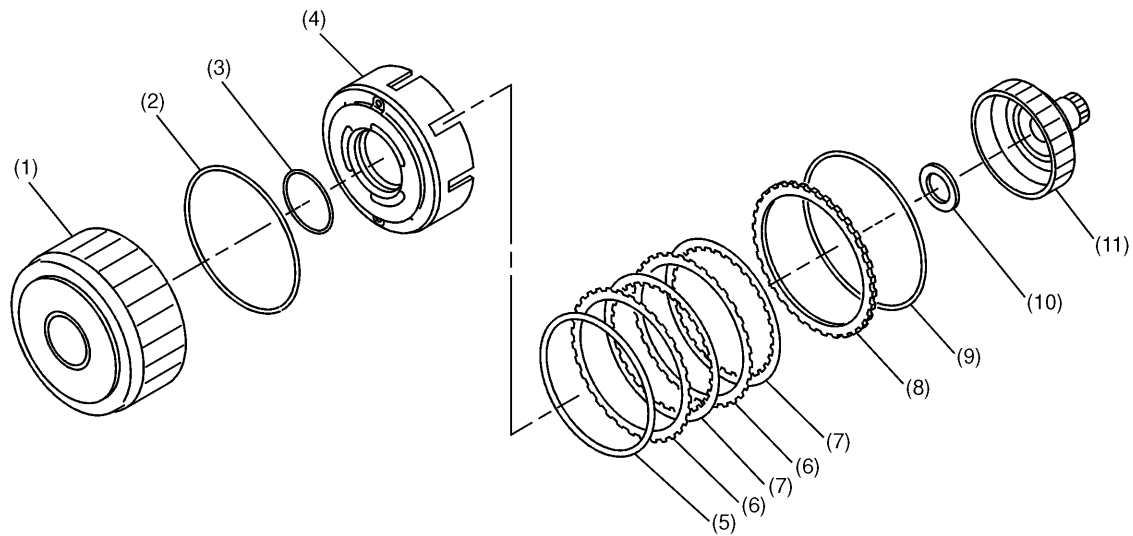

B3H0891A

- (1) High clutch drum
- (2) Lip seal
- (3) Lathe cut seal ring
- (4) Reverse clutch piston
- (5) Dish plate
- (6) Driven plate

- (7) Drive plate
- (8) Retaining plate
- (9) Snap ring
- (10) Thrust needle bearing
- (11) High clutch hub

# REVERSE CLUTCH

Automatic Transmission

## B: FUNCTION

### 1. WHEN REVERSE IS SELECTED

Hydraulic pressure from the hydraulic control valve is applied to the reverse clutch piston when a shift is made into the reverse. The drive and driven plates are pressed together by this pressure, so that the engine torque from the high clutch drum is transmitted to the front sun gear through the 2-4 brake hub.

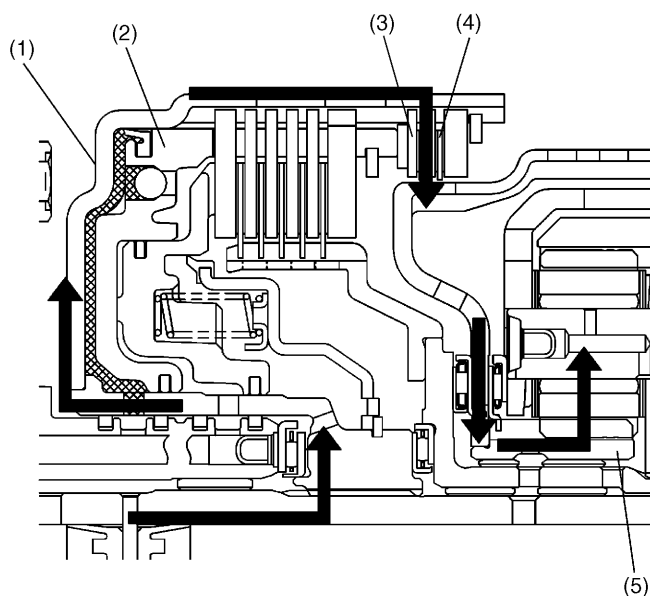

- (1) High clutch drum
- (2) Reverse clutch piston
- (3) Driven plate

- (4) Drive plate
- (5) Front sun gear

B3H2071A

# REVERSE CLUTCH

Automatic Transmission

## 2. WHEN REVERSE IS NOT SELECTED

When the selector lever is in any position other than the reverse, no pressure is applied to the reverse clutch piston. Hence the drive and driven plates are separated from each other, transmitting no power to any element beyond them.

A check ball is built into the clutch piston. This check ball has a function of releasing the pressure which may build up in the fluid remaining behind the piston by centrifugal force generated by the idly rotating high clutch drum, thereby avoiding a half-engaged state of the clutch.

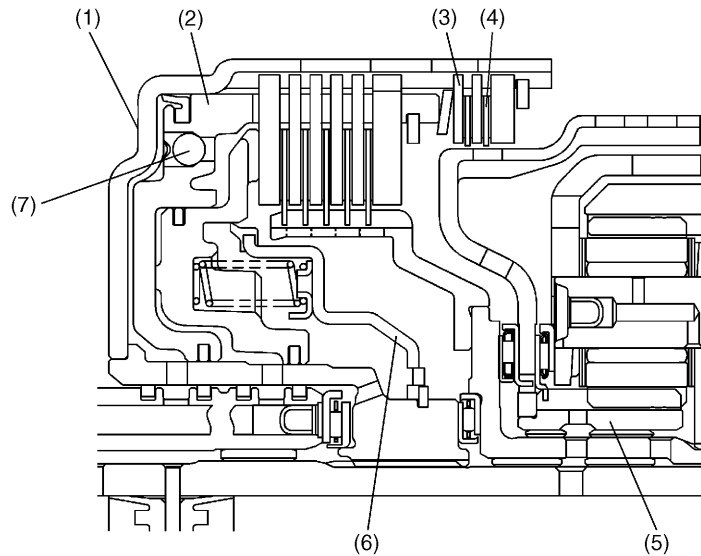

B3H2072A

- |                           |                    |
|---------------------------|--------------------|
| (1) High clutch drum      | (5) Front sun gear |
| (2) Reverse clutch piston | (6) Cover          |
| (3) Driven plate          | (7) Check ball     |
| (4) Drive plate           |                    |