

2-4 BRAKE

Automatic Transmission

4. 2-4 Brake

A: CONSTRUCTION

The 2-4 brake consists of a 2-4 brake piston, a spring retainer, a pressure plate, drive plates and driven plates.

This brake is engaged by the hydraulic pressure from the transmission control valve and locks the front sun gear when the 2nd gear is selected in the D, 3 or 2 range, or when the 4th gear is selected in the D range.

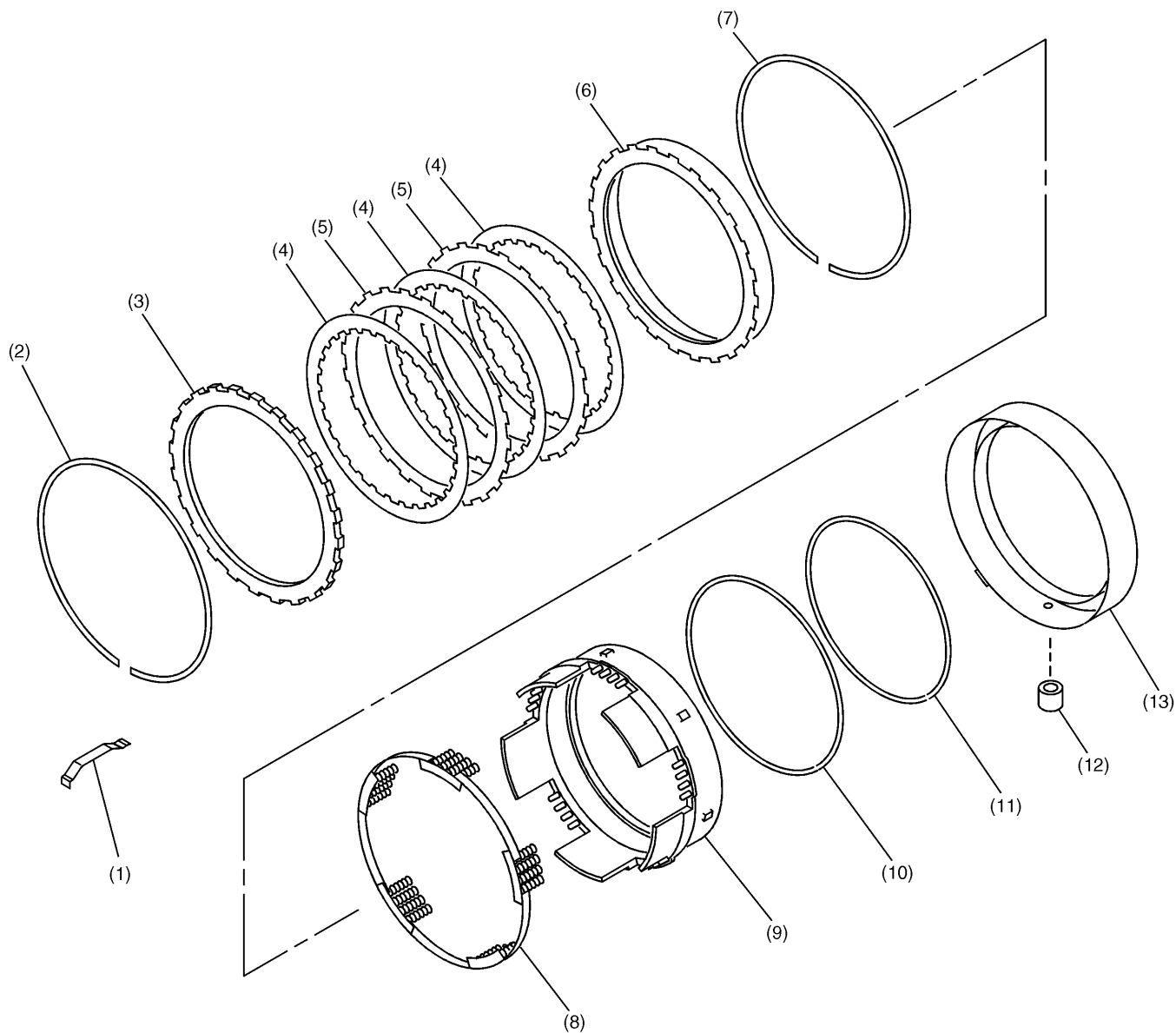

B3H0895A

- | | | |
|---------------------|-------------------------|--------------------------------|
| (1) Leaf spring | (6) Pressure rear plate | (10) Lathe cut seal ring |
| (2) Snap ring | (7) Snap ring | (11) Lathe cut seal ring |
| (3) Retaining plate | (8) Spring retainer | (12) 2-4 brake piston seal |
| (4) Drive plate | (9) 2-4 brake piston | (13) 2-4 brake piston retainer |
| (5) Driven plate | | |