

# GENERAL DESCRIPTION

Automatic Transmission

## 1. General Description S510001

### A: SPECIFICATIONS S510001E49

#### 1. DRIVE PLATE AND DRIVEN PLATE S510001E4901

Plate number of high clutch	1.6 L	3
	2.0 L	4
	2.0 L TURBO	5
	2.5 L	4
	3.0 L	5
Plate number of reverse clutch	1.6 L	1
	2.0 L	2
	2.0 L TURBO	2
	2.5 L	2
	3.0 L	2
Plate number of 2-4 brake	1.6 L	2
	2.0 L	3
	2.0 L TURBO	4
	2.5 L	3
	3.0 L	4
Plate number of low clutch	1.6 L	4
	2.0 L	4
	2.0 L TURBO	7
	2.5 L	6
	3.0 L	7
Plate number of low and reverse brake	1.6 L	4
	2.0 L	4
	2.0 L TURBO	7
	2.5 L	6
	3.0 L	7
Plate number of transfer clutch	1.6 L	4
	2.0 L	4
	2.0 L TURBO (Without VTD)	6
	2.0 L TURBO (With VTD)	3
	2.5 L (Without VTD)	5
	2.5 L (With VTD)	3
	3.0 L (Without VTD)	6
	3.0 L (With VTD)	3

## 2. AUTOMATIC TRANSMISSION FLUID CAPACITY S510001E4902

Dexron III type Automatic transmission fluid	
1.6 L, 2.0 L	8.4 — 8.7 ℓ (8.9 — 9.2 US qt, 7.4 — 7.7 Imp qt)
2.0 L TURBO, 2.5 L, 3.0 L	9.3 — 9.6 ℓ (9.8 — 10.1 US qt, 8.2 — 8.4 Imp qt)

## 3. FRONT DIFFERENTIAL OIL CAPACITY S510001E4903

Recommended oil	Oil capacity
GL-5	1.1 — 1.2 ℓ (1.2 — 1.3 US qt, 1.0 — 1.1 Imp qt)

# GENERAL DESCRIPTION

Automatic Transmission

---

MEMO:

# GENERAL DESCRIPTION

Automatic Transmission

## B: COMPONENT SS10001A05

### 1. TORQUE CONVERTER CLUTCH AND CASE SS10001A0501

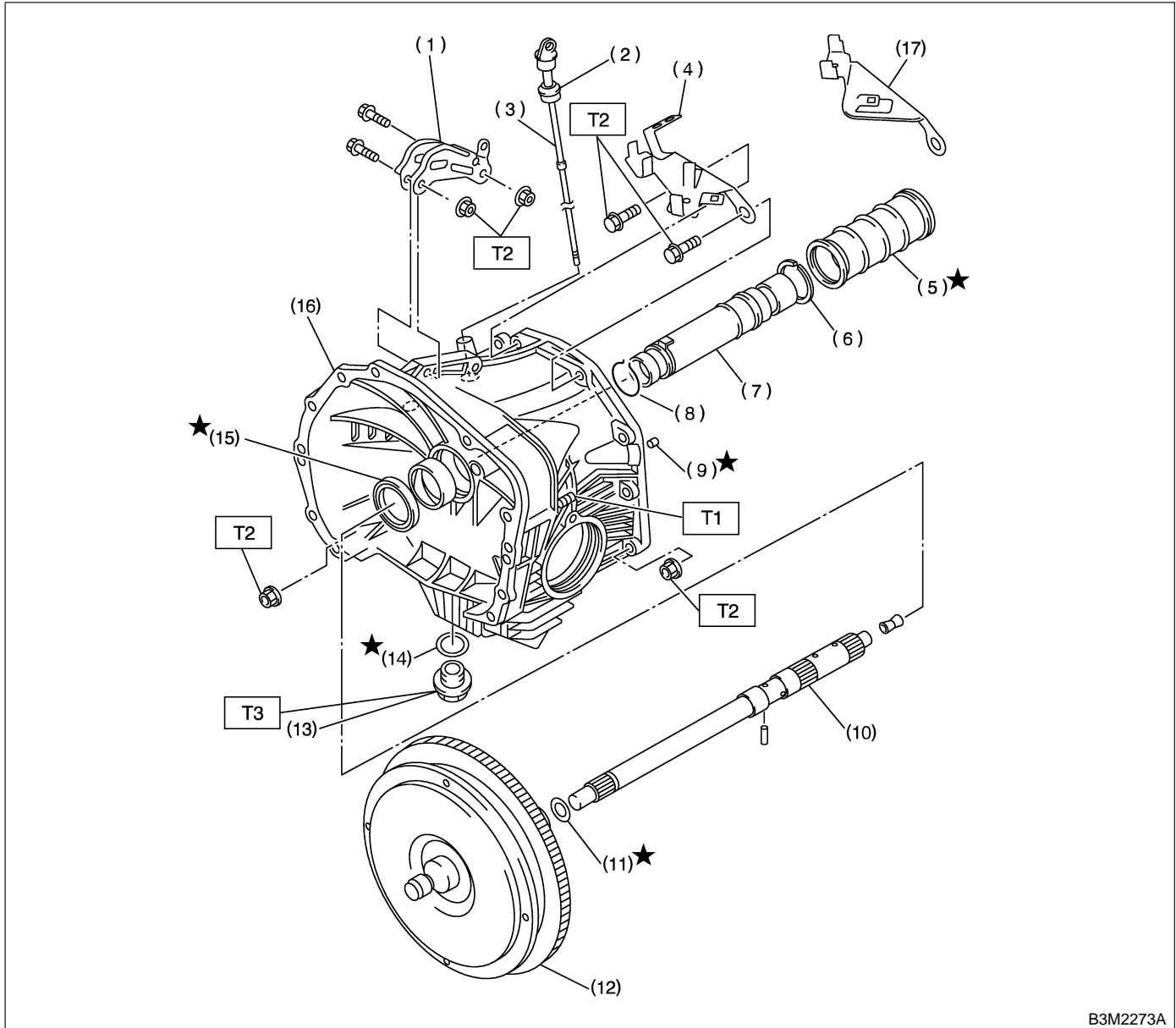

B3M2273A

- (1) Pitching stopper bracket
- (2) O-ring
- (3) Differential oil level gauge
- (4) Stay (Except for Legacy)
- (5) Seal pipe
- (6) Seal ring
- (7) Oil pump shaft
- (8) Clip

- (9) Oil drain pipe
- (10) Input shaft
- (11) O-ring
- (12) Torque converter clutch ASSY
- (13) Drain plug
- (14) Gasket
- (15) Oil seal
- (16) Torque converter clutch case

- (17) Stay (For Legacy)

**Tightening torque: N·m (kgf·m, ft·lb)**

**T1: 18 (1.8, 13.0)**

**T2: 41 (4.2, 30.4)**

**T3: 44 (4.5, 32.5)**

## 2. OIL PUMP SS10001A0502

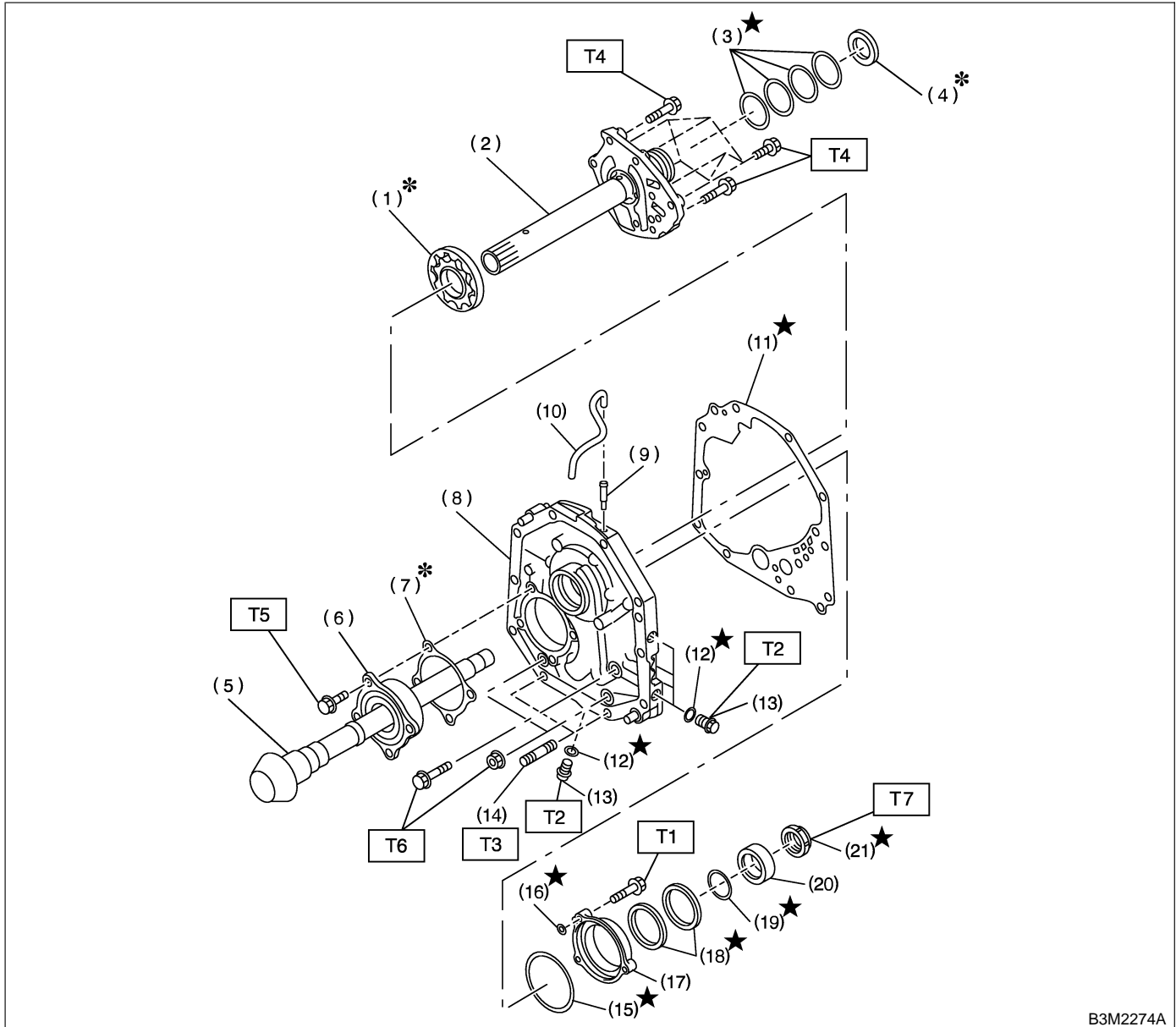

B3M2274A

- |                           |                          |
|---------------------------|--------------------------|
| (1) Oil pump rotor        | (12) O-ring              |
| (2) Oil pump cover        | (13) Test plug           |
| (3) Seal ring             | (14) Stud bolt           |
| (4) Thrust needle bearing | (15) O-ring              |
| (5) Drive pinion shaft    | (16) O-ring              |
| (6) Roller bearing        | (17) Oil seal retainer   |
| (7) Shim                  | (18) Oil seal            |
| (8) Oil pump housing      | (19) O-ring              |
| (9) Nipple                | (20) Drive pinion collar |
| (10) Air breather hose    | (21) Lock nut            |
| (11) Gasket               |                          |

**Tightening torque: N·m (kgf·m, ft·lb)**

- |                           |
|---------------------------|
| <b>T1: 7 (0.7, 5.1)</b>   |
| <b>T2: 13 (1.3, 9.4)</b>  |
| <b>T3: 18 (1.8, 13.0)</b> |
| <b>T4: 25 (2.5, 18.1)</b> |
| <b>T5: 40 (4.1, 30)</b>   |
| <b>T6: 42 (4.3, 31)</b>   |
| <b>T7: 116 (11.8, 85)</b> |

# GENERAL DESCRIPTION

Automatic Transmission

## 3. TRANSMISSION CASE AND CONTROL DEVICE

SS10001A0503

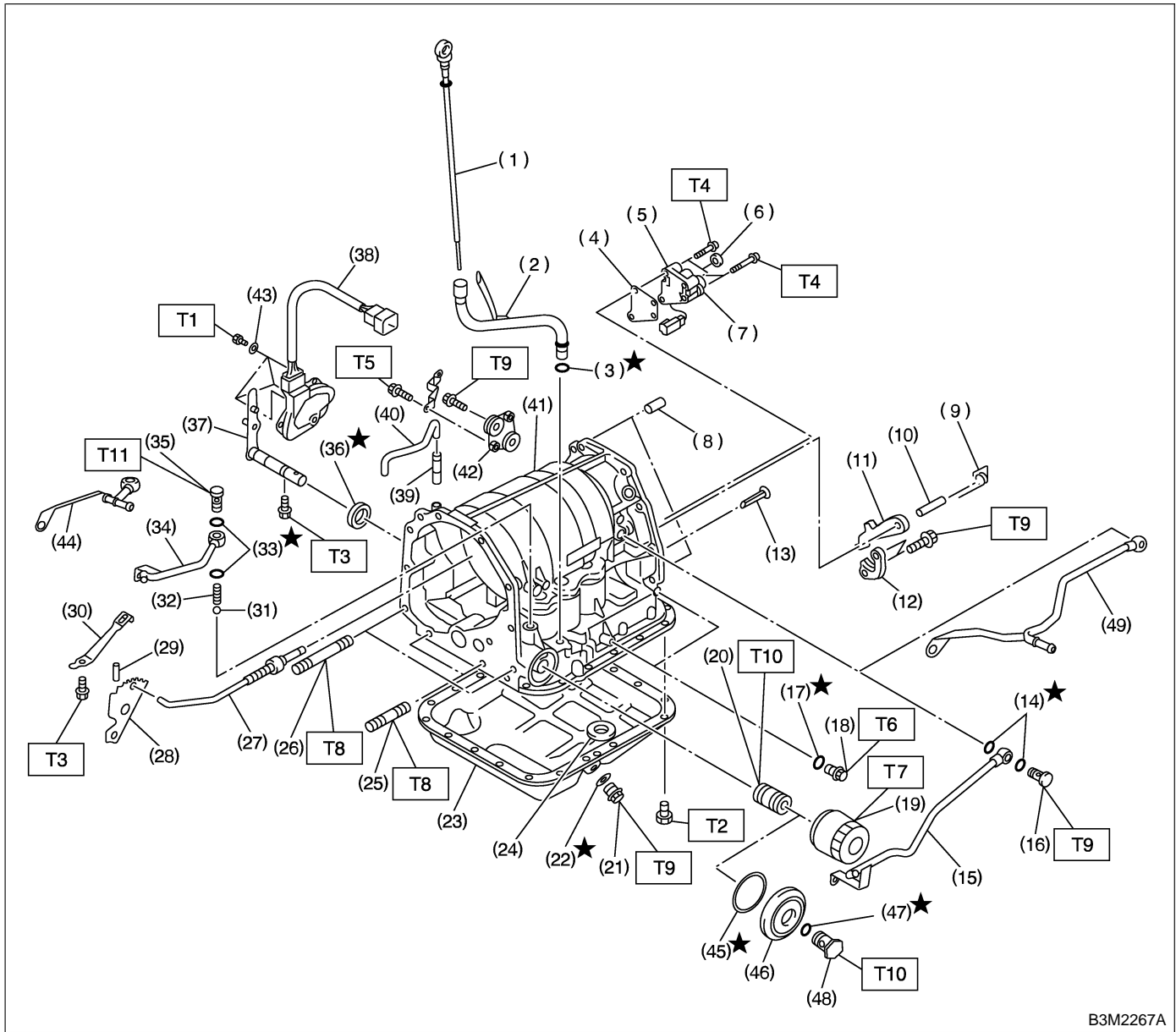

B3M2267A

# GENERAL DESCRIPTION

Automatic Transmission

---

(1) ATF level gauge	(22) Gasket	(43) Washer
(2) ATF charger pipe	(23) Oil pan	(44) Outlet pipe (Except for Forester)
(3) O-ring	(24) Magnet	(45) O-ring (3.0 L model)
(4) Transfer valve plate	(25) Stud bolt (Short)	(46) Cover (3.0 L model)
(5) Transfer valve ASSY	(26) Stud bolt (Long)	(47) Gasket (3.0 L model)
(6) Transfer clutch seal	(27) Parking rod	(48) Union screw (3.0 L model)
(7) Transfer duty solenoid	(28) Manual plate	(49) Inlet pipe (Except for Forester)
(8) Straight pin	(29) Spring pin	
(9) Return spring	(30) Detention spring	<b><i>Tightening torque: N·m (kgf·m, ft·lb)</i></b>
(10) Shaft	(31) Ball	<b><i>T1: 3.4 (0.35, 2.5)</i></b>
(11) Parking pawl	(32) Spring	<b><i>T2: 5 (0.5, 3.6)</i></b>
(12) Parking support	(33) Gasket	<b><i>T3: 6 (0.6, 4)</i></b>
(13) Inlet filter	(34) Outlet pipe (For Forester)	<b><i>T4: 8 (0.8, 6)</i></b>
(14) Gasket	(35) Union screw	<b><i>T5: 12 (1.2, 8.7)</i></b>
(15) Inlet pipe (Except for Forester)	(36) Oil seal	<b><i>T6: 13 (1.3, 10)</i></b>
(16) Union screw	(37) Select lever	<b><i>T7: 14 (1.4, 10)</i></b>
(17) O-ring	(38) Inhibitor switch ASSY	<b><i>T8: 18 (1.8, 13)</i></b>
(18) Test plug	(39) Nipple	<b><i>T9: 25 (2.6, 18)</i></b>
(19) Oil filter (Except 3.0 L model)	(40) Air breather hose	<b><i>T10: 44 (4.5, 32)</i></b>
(20) Oil filter stud bolt	(41) Transmission case	
(21) Drain plug	(42) Plate ASSY	

---

# GENERAL DESCRIPTION

Automatic Transmission

## 4. CONTROL VALVE AND HARNESS ROUTING

SS10001A0504

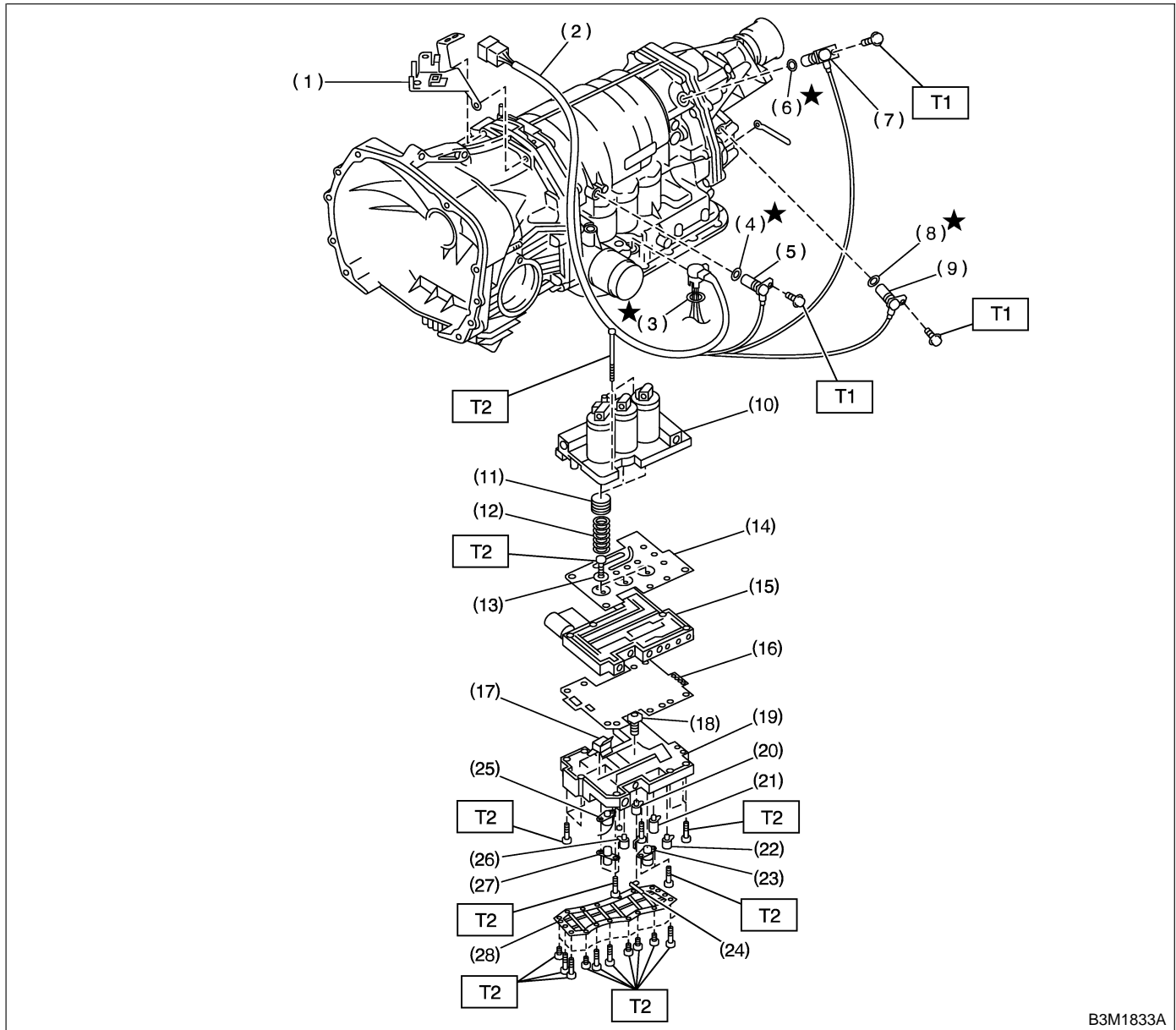

B3M1833A

- (1) Stay
- (2) Transmission harness
- (3) O-ring
- (4) O-ring
- (5) Torque converter turbine speed sensor
- (6) O-ring
- (7) Front vehicle speed sensor
- (8) O-ring
- (9) Rear vehicle speed sensor
- (10) Upper valve body
- (11) Accumulator piston

- (12) Accumulator spring
- (13) Side plate
- (14) Separate plate
- (15) Middle valve body
- (16) Separate plate
- (17) Fluid filter
- (18) Fluid filter
- (19) Lower valve body
- (20) Shift solenoid 2
- (21) Shift solenoid 1
- (22) 2-4 brake timing solenoid
- (23) 2-4 brake duty solenoid

- (24) ATF temperature sensor
- (25) Line pressure duty solenoid
- (26) Low clutch timing solenoid
- (27) Lock-up duty solenoid
- (28) Oil strainer

**Tightening torque: N·m (kgf·m, ft·lb)**

**T1: 7 (0.7, 5.1)**

**T2: 8 (0.8, 5.8)**

## 5. HIGH CLUTCH AND REVERSE CLUTCH

S510001A0505

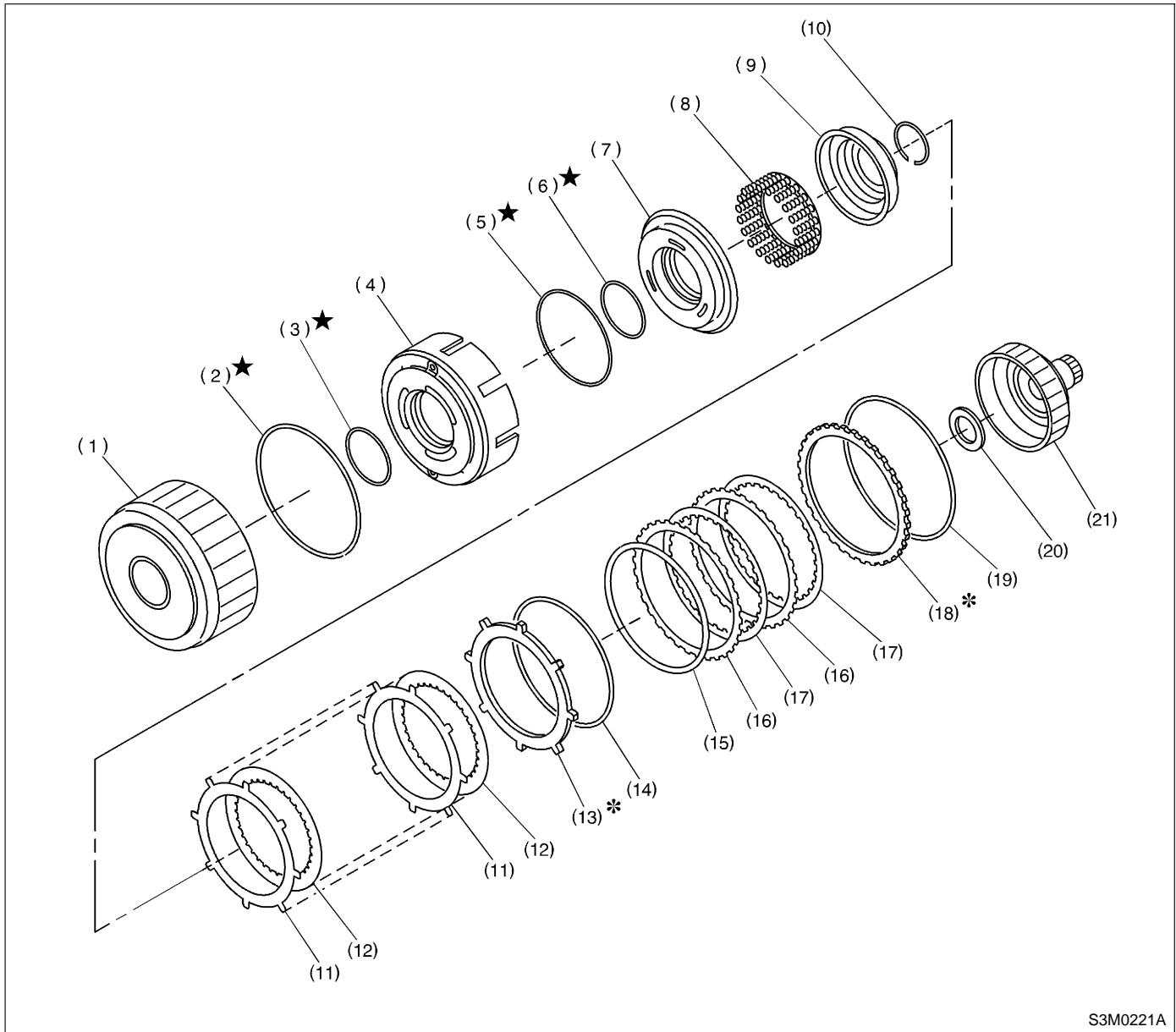

S3M0221A

- |                           |                      |                            |
|---------------------------|----------------------|----------------------------|
| (1) High clutch drum      | (8) Spring retainer  | (15) Dish plate            |
| (2) Lip seal              | (9) Cover            | (16) Driven plate          |
| (3) Lathe cut seal ring   | (10) Snap ring       | (17) Drive plate           |
| (4) Reverse clutch piston | (11) Driven plate    | (18) Retaining plate       |
| (5) Lathe cut seal ring   | (12) Drive plate     | (19) Snap ring             |
| (6) Lathe cut seal ring   | (13) Retaining plate | (20) Thrust needle bearing |
| (7) High clutch piston    | (14) Snap ring       | (21) High clutch hub       |



# GENERAL DESCRIPTION

Automatic Transmission

## 6. PLANETARY GEAR AND 2-4 BRAKE

S510001A0506

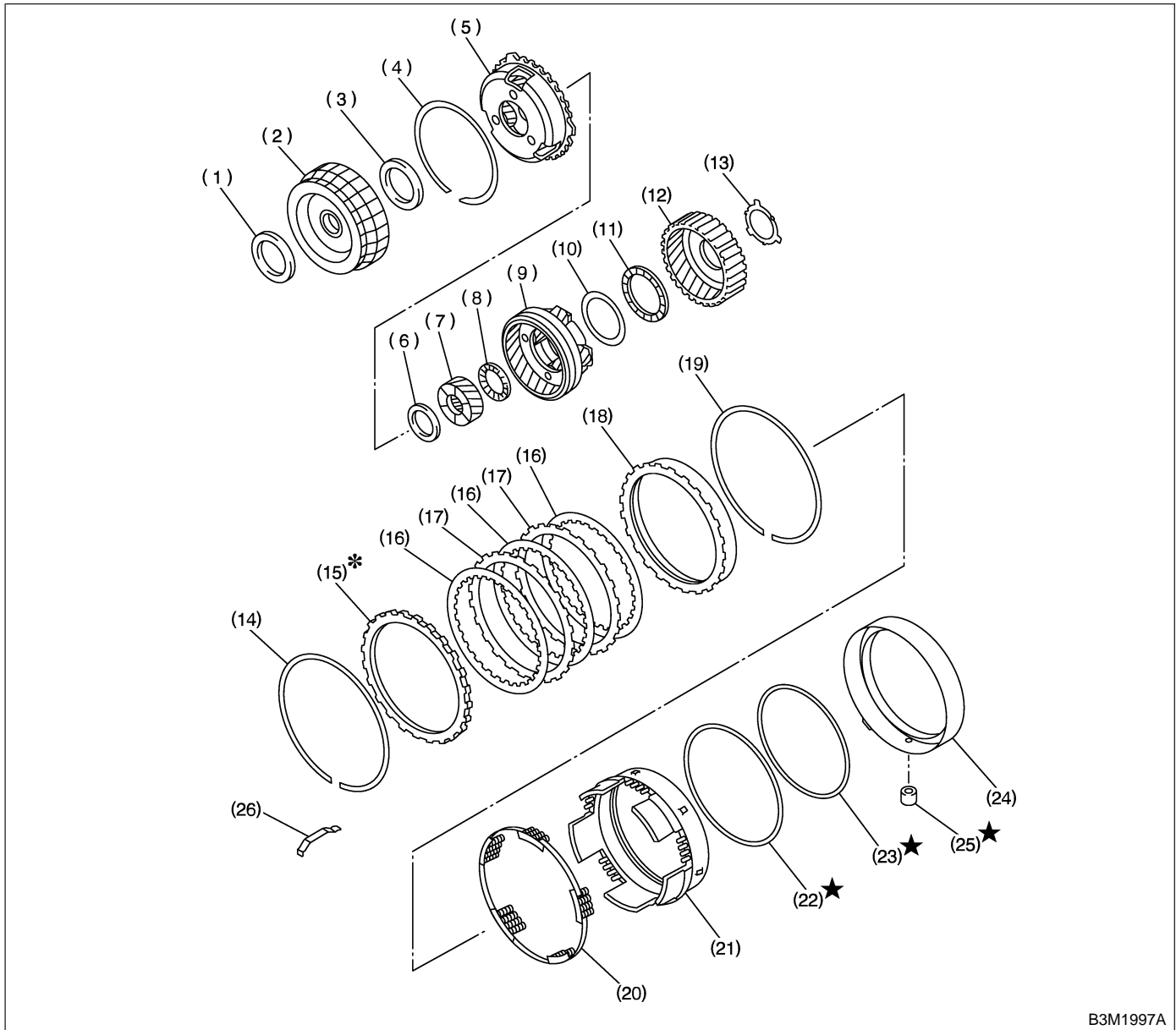

B3M1997A

- |                             |                            |                                |
|-----------------------------|----------------------------|--------------------------------|
| (1) Thrust needle bearing   | (10) Washer                | (19) Snap ring                 |
| (2) Front sun gear          | (11) Thrust needle bearing | (20) Spring retainer           |
| (3) Thrust needle bearing   | (12) Rear internal gear    | (21) 2-4 brake piston          |
| (4) Snap ring               | (13) Washer                | (22) Lathe cut seal ring       |
| (5) Front planetary carrier | (14) Snap ring             | (23) Lathe cut seal ring       |
| (6) Thrust needle bearing   | (15) Retaining plate       | (24) 2-4 brake piston retainer |
| (7) Rear sun gear           | (16) Drive plate           | (25) 2-4 brake seal            |
| (8) Thrust needle bearing   | (17) Driven plate          | (26) Leaf spring               |
| (9) Rear planetary carrier  | (18) Pressure rear plate   |                                |

## 7. LOW CLUTCH AND LOW & REVERSE BRAKE

SS10001A0507

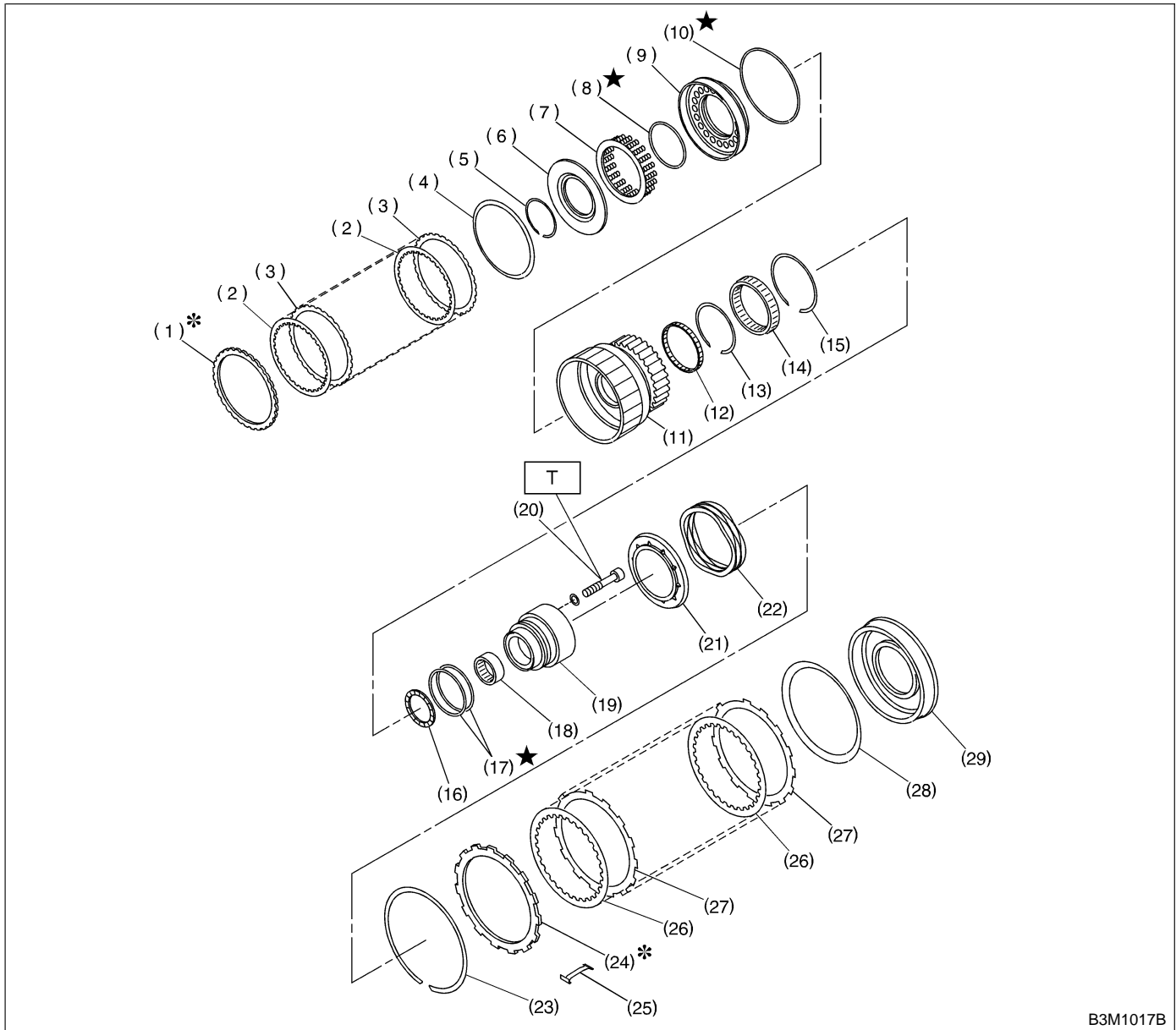

B3M1017B

- |                          |                                |                                   |
|--------------------------|--------------------------------|-----------------------------------|
| (1) Retaining plate      | (12) Needle bearing            | (23) Snap ring                    |
| (2) Drive plate          | (13) Inner snap ring           | (24) Retaining plate              |
| (3) Driven plate         | (14) One-way clutch            | (25) Leaf spring                  |
| (4) Dish plate           | (15) Outer snap ring           | (26) Drive plate                  |
| (5) Snap ring            | (16) Thrust needle bearing     | (27) Driven plate                 |
| (6) Cover                | (17) Seal ring                 | (28) Dish plate                   |
| (7) Spring retainer      | (18) Needle bearing            | (29) Low and reverse brake piston |
| (8) Lathe cut seal ring  | (19) One-way clutch inner race |                                   |
| (9) Low clutch piston    | (20) Socket bolt               |                                   |
| (10) Lathe cut seal ring | (21) Spring retainer           |                                   |
| (11) Low clutch drum     | (22) Return spring             |                                   |

**Tightening torque: N·m (kgf·m, ft·lb)**  
**T: 25 (2.5, 18.1)**

# GENERAL DESCRIPTION

Automatic Transmission

## 8. REDUCTION GEAR WITHOUT VTD

S510001A0508

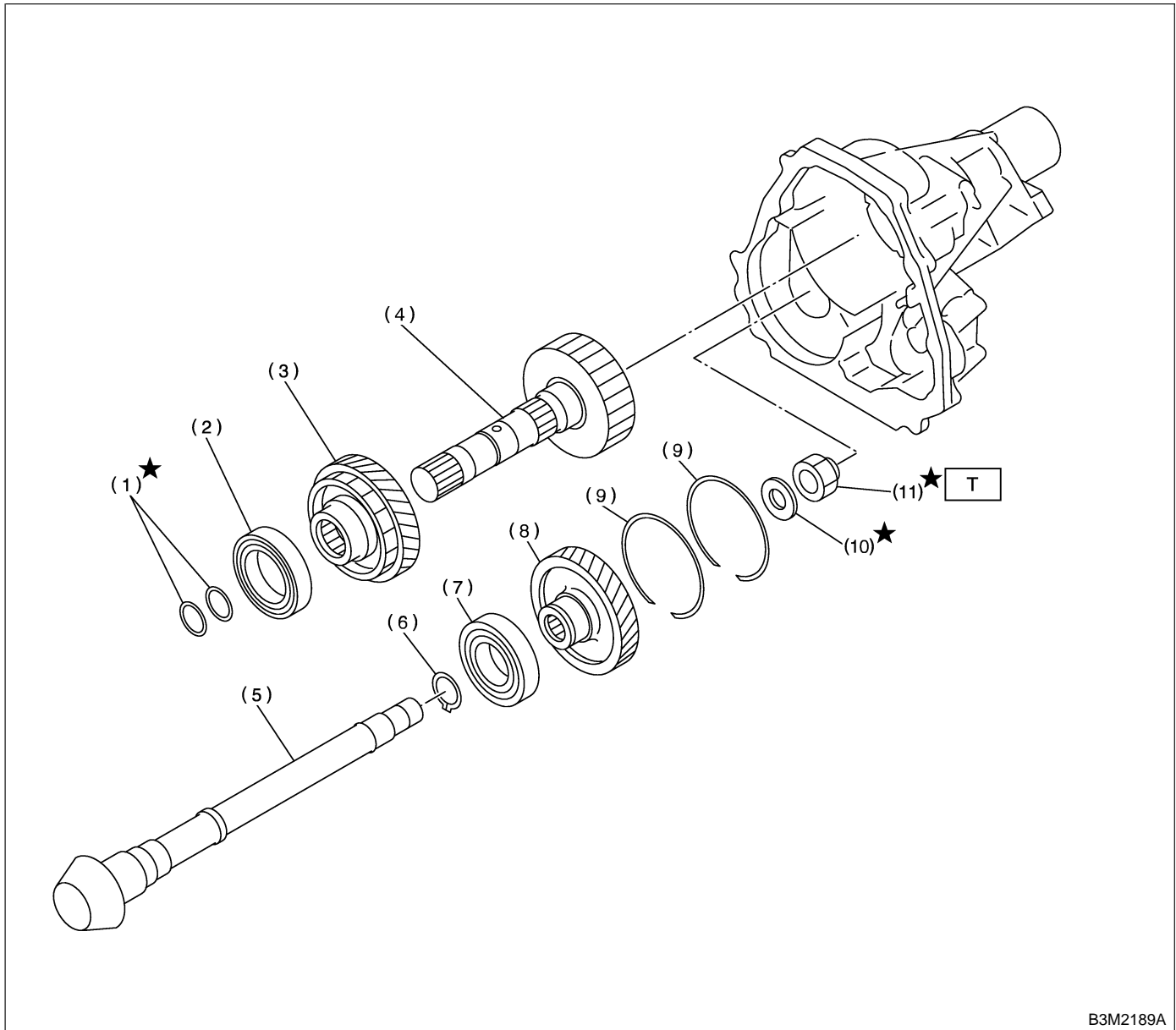

B3M2189A

- (1) Seal ring
- (2) Ball bearing
- (3) Reduction drive gear
- (4) Reduction drive shaft
- (5) Drive pinion shaft

- (6) Snap ring
- (7) Ball bearing
- (8) Reduction driven gear
- (9) Snap ring (Legacy 2.5 L US model and 3.0 L model)

- (10) Washer
- (11) Lock nut

**Tightening torque: N·m (kgf·m, ft·lb)**  
**T: 100 (10.2, 73.8)**

## 9. REDUCTION GEAR WITH VTD S510001A0509

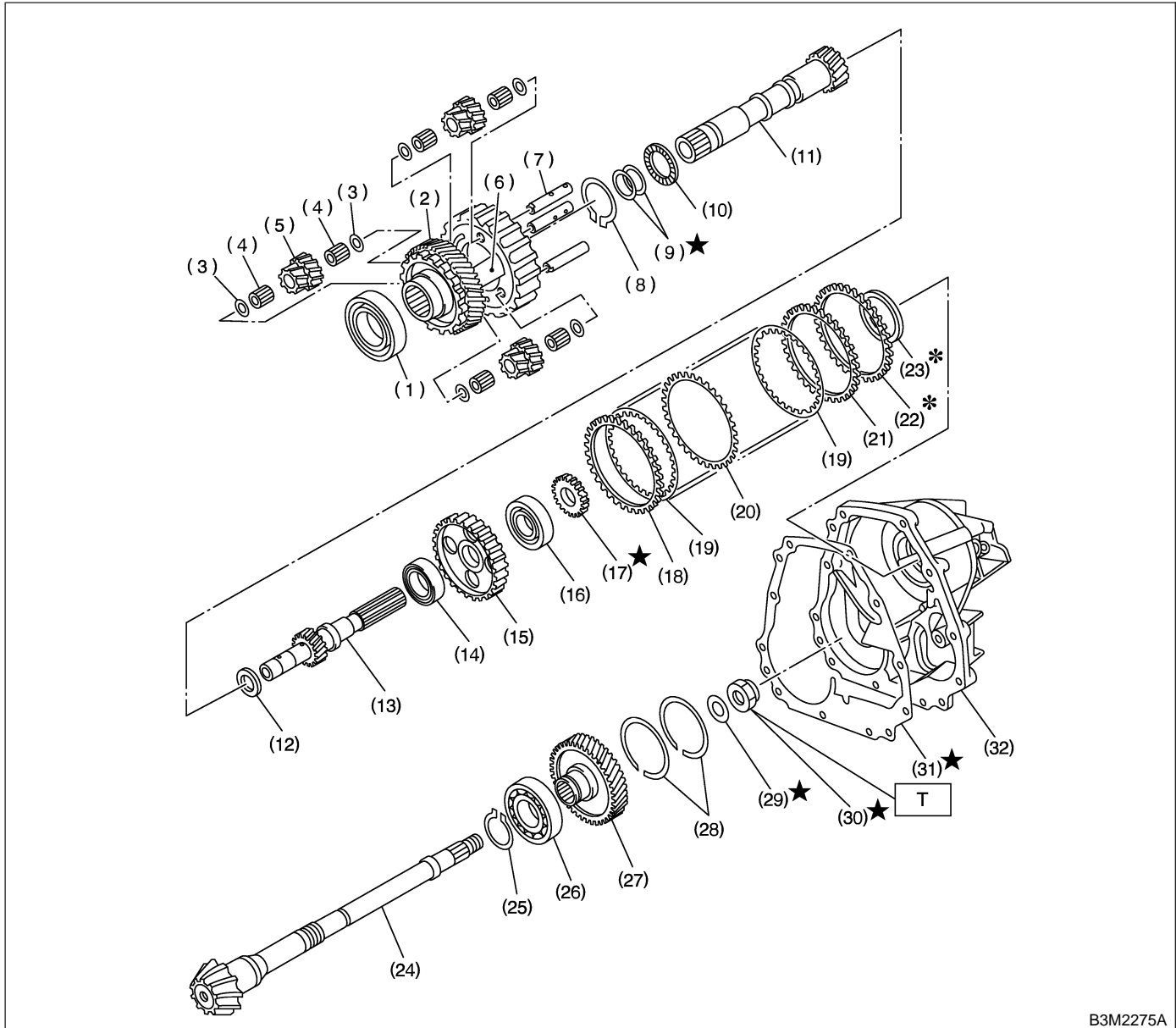

B3M2275A

- |                            |                                   |  |
|----------------------------|-----------------------------------|--|
| (1) Ball bearing           | (14) Ball bearing                 | (27) Reduction driven gear                             |
| (2) Reduction drive gear   | (15) Multi-plate clutch (LSD) hub | (28) Snap ring (Legacy 2.5 L US model and 3.0 L model) |
| (3) Washer                 | (16) Ball bearing                 | (29) Lock washer                                       |
| (4) Needle bearing         | (17) Revolution gear              | (30) Lock nut  |
| (5) Pinion gear            | (18) Driven plate (Thicker)       | (31) Gasket  |
| (6) Carrier                | (19) Drive plate                  | (32) Extension case                                    |
| (7) Planetary pinion shaft | (20) Driven plate (Thinner)       |  |
| (8) Snap ring              | (21) Driven plate (Thicker)       |  |
| (9) Seal ring              | (22) Adjust plate                 |  |
| (10) Thrust needle bearing | (23) Rear drive shaft shim        |  |
| (11) Intermediate shaft    | (24) Drive pinion shaft           |  |
| (12) Thrust washer         | (25) Snap ring                    |  |
| (13) Rear drive shaft      | (26) Ball bearing                 |  |

---

**Tightening torque: N·m (kgf·m, ft·lb)**  
**T: 100 (10.2, 73.8)**

---

# GENERAL DESCRIPTION

Automatic Transmission

## 10. DIFFERENTIAL GEAR S510001A0510

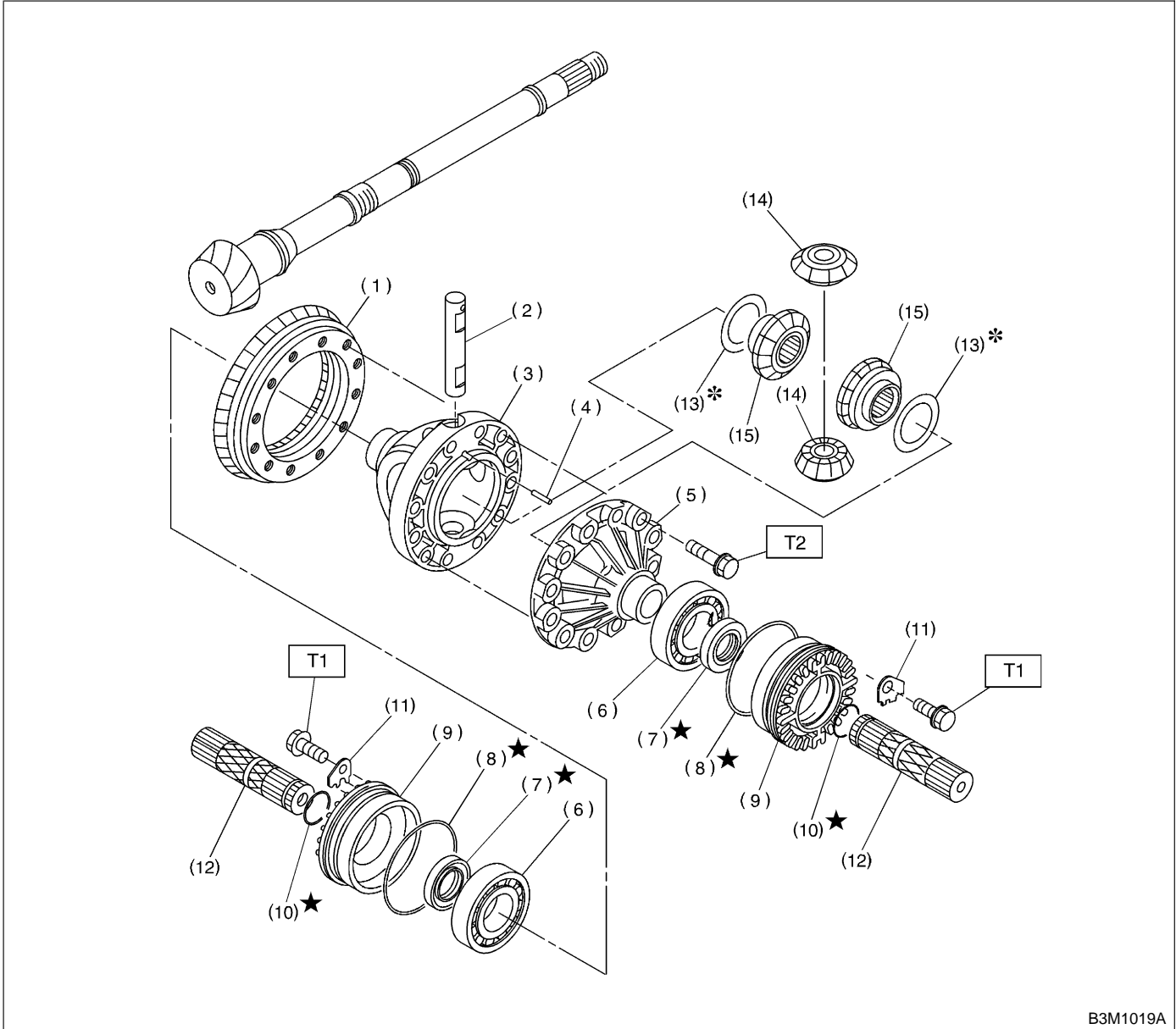

B3M1019A

- |                            |                                |
|----------------------------|--------------------------------|
| (1) Crown gear             | (8) O-ring                     |
| (2) Pinion shaft           | (9) Differential side retainer |
| (3) Differential case (RH) | (10) Circlip                   |
| (4) Straight pin           | (11) Lock plate                |
| (5) Differential case (LH) | (12) Axle shaft                |
| (6) Taper roller bearing   | (13) Washer                    |
| (7) Oil seal               | (14) Differential bevel pinion |

- (15) Differential bevel gear

**Tightening torque: N·m (kgf·m, ft·lb)**

**T1: 25 (2.5, 18.1)**

**T2: 62 (6.3, 45.6)**

## 11. TRANSFER AND EXTENSION CASE WITHOUT VTD

SS10001A0511

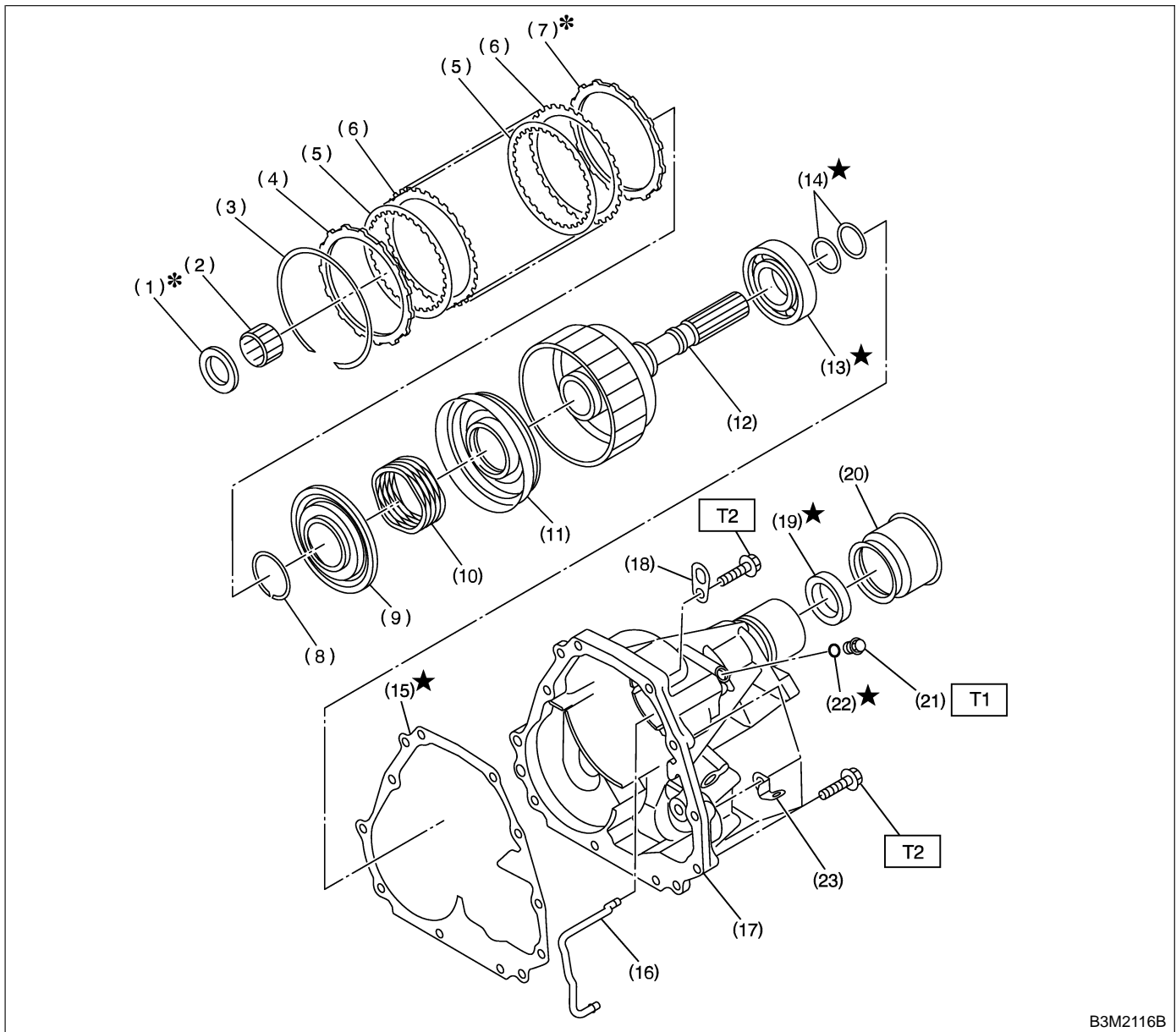

B3M2116B

- (1) Thrust needle bearing
- (2) Needle bearing
- (3) Snap ring
- (4) Pressure plate
- (5) Drive plate
- (6) Driven plate
- (7) Pressure plate
- (8) Snap ring
- (9) Transfer piston seal
- (10) Return spring

- (11) Transfer clutch piston
- (12) Rear drive shaft
- (13) Ball bearing
- (14) Seal ring
- (15) Gasket
- (16) Transfer clutch pipe
- (17) Extension case
- (18) Transmission hanger
- (19) Oil seal
- (20) Dust cover

- (21) Test plug
- (22) O-ring
- (23) Clip

**Tightening torque: N·m (kgf·m, ft·lb)**

**T1: 13 (1.3, 9.4)**

**T2: 25 (2.5, 18.1)**

# GENERAL DESCRIPTION

Automatic Transmission

## 12. TRANSFER AND EXTENSION CASE WITH VTD

S510001A0512

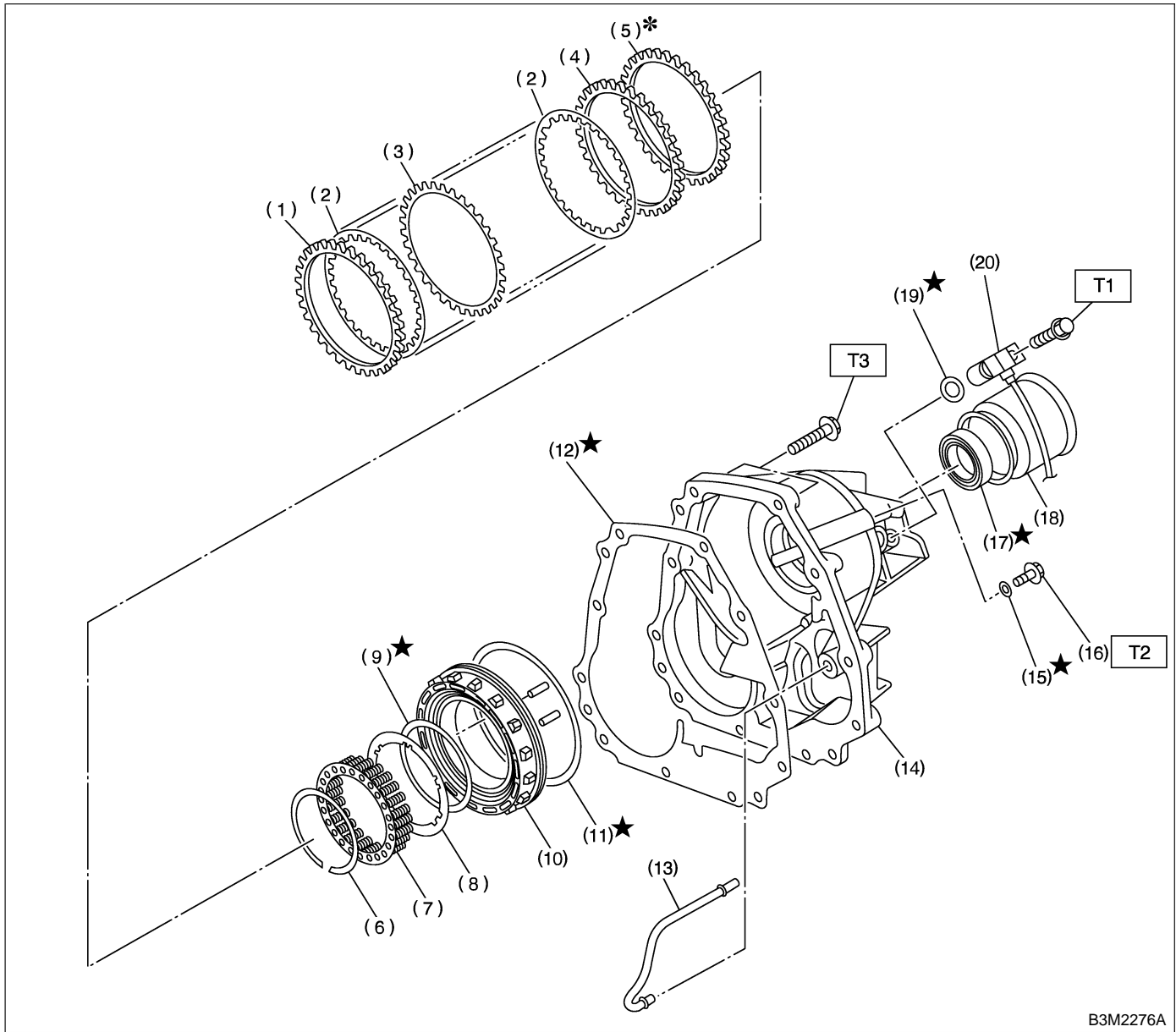

B3M2276A

- (1) Driven plate (Thicker)
- (2) Drive plate
- (3) Driven plate (Thinner)
- (4) Driven plate (Thicker)
- (5) Adjust plate
- (6) Snap ring
- (7) Spring retainer
- (8) Plate
- (9) Lathe cut seal ring

- (10) Multi-plate clutch (LSD) piston ASSY
- (11) Lathe cut seal ring
- (12) Gasket
- (13) Multi-plate clutch (LSD) pipe
- (14) Extension case
- (15) O-ring
- (16) Test plug
- (17) Oil seal

- (18) Dust cover
- (19) O-ring
- (20) Rear vehicle speed sensor

**Tightening torque: N·m (kgf·m, ft·lb)**

**T1: 7 (0.7, 5.1)**

**T2: 13 (1.3, 9.4)**

**T3: 25 (2.5, 18.1)**

**C: PRECAUTION** SS10001F59

When disassembling or assembling the automatic transmission, observe the following instructions.

**1) Workshop**

Provide a place that is clean and free from dust. Principally the conventional workshop is suitable except for a dusty place. In a workshop where grinding work, etc. which produces fine particles is done, make independent place divided by the vinyl curtain or the equivalent.

**2) Work table**

The size of 1 x 1.5 m (40 x 60 in) is large enough to work, and it is more desirable that its surface be covered with flat plate like iron plate which is not rusted too much.

**3) Cleaning of exterior**

(1) Clean the exterior surface of transmission with steam and/or kerosene prior to disassembly, however it should be noted that vinyl tape be placed on the air breather or oil level gauge to prevent infiltration of the steam into the transmission and also the cleaning job be done away from the place of disassembly and assembly.

(2) Partial cleaning will do, depending on the extent of disassembly (such as when disassembly is limited to some certain parts).

**4) Disassembly, assembly and cleaning**

(1) Disassemble and assemble the transmission while inspecting the parts in accordance with the Diagnostics.

(2) During job, do not use gloves. Do not clean the parts with rags: Use chamois or nylon cloth.

(3) Pay special attention to the air to be used for cleaning. Get the moisture and the dust rid of the air as much as possible. Be careful not to scratch or dent any part while checking for proper operation with an air gun.

(4) Complete the job from cleaning to completion of assembly as continuously and speedily as possible in order to avoid occurrence of secondary troubles caused by dust. When stopping the job unavoidably cover the parts with clean chamois or nylon cloth to keep them away from any dust.

(5) Use kerosene, white gasoline or the equivalent as washing fluid. Use always new fluid for cleaning the automatic transmission parts and never reuse. The used fluid is usable in disassemble and assemble work of engine and manual transmission.

(6) Although the cleaning should be done by dipping into the washing fluid or blowing of the pressurized washing fluid, the dipping is more desirable. (Do not rub with a brush.) Assemble the parts immediately after the cleaning without exposure to the air for a while. Besides in case

of washing rubber parts, perform the job quickly not to dip them into the washing fluid for long time.

(7) Apply the automatic transmission fluid (ATF) onto the parts immediately prior to assembly, and the specified tightening torque should be observed carefully.

(8) Use vaseline if it is necessary to hold parts in the position when assembling.

(9) Drain ATF and differential gear oil into a saucer so that the conditions of fluid and oil can be inspected.

(10) Do not support axle drive shaft, stator shaft, input shaft or various pipes when moving transmission from one place to another.

(11) Always discard old oil seals and O-ring, and install new ones.

(12) Be sure to replace parts which are damaged, worn, scratched, discolored, etc.



# GENERAL DESCRIPTION

Automatic Transmission

## D: PREPARATION TOOL S510001A17

### 1. SPECIAL TOOLS S510001A1701

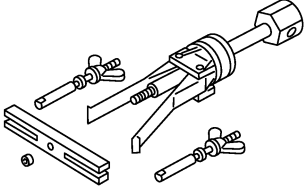
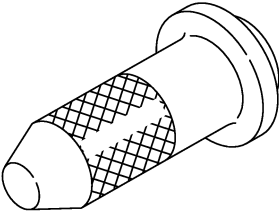
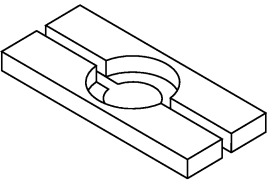
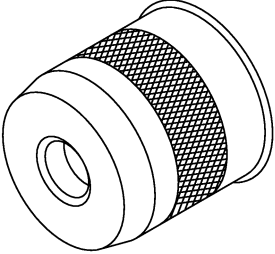
ILLUSTRATION	TOOL NUMBER	DESCRIPTION	REMARKS
 <p style="text-align: right; margin-right: 10px;">B3M1977</p>	398527700	PULLER ASSY	<ul style="list-style-type: none"> <li>● Used for removing extension case roller bearing.</li> <li>● Used for removing extension oil seal.</li> <li>● Used for removing front differential side retainer bearing outer race.</li> </ul>
 <p style="text-align: right; margin-right: 10px;">B3M1972</p>	498057300	INSTALLER	Used for installing extension oil seal.
 <p style="text-align: right; margin-right: 10px;">B3M1998</p>	498077000	REMOVER	Used for removing differential taper roller bearing.
 <p style="text-align: right; margin-right: 10px;">B3M1999</p>	499247400	INSTALLER	<ul style="list-style-type: none"> <li>● Used for installing transfer outer snap ring.</li> <li>● Used with GUIDE (499257300).</li> </ul>

# GENERAL DESCRIPTION

Automatic Transmission

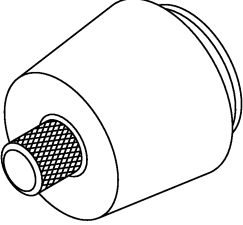
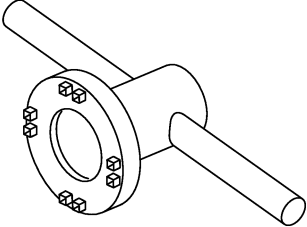
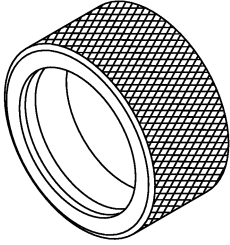
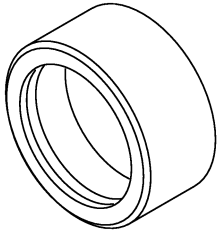
ILLUSTRATION	TOOL NUMBER	DESCRIPTION	REMARKS
 <p style="text-align: right;">B3M2000</p>	499257300	SNAP RING OUTER GUIDE	<ul style="list-style-type: none"> <li>● Used for installing transfer outer snap ring.</li> <li>● Used with INSTALLER (499247400).</li> </ul>
 <p style="text-align: right;">B3M1953</p>	499787000	WRENCH ASSY	Used for removing and installing differential side retainer.
 <p style="text-align: right;">B3M2001</p>	398437700	DRIFT	Used for installing converter case oil seal.
 <p style="text-align: right;">B3M1912</p>	398487700	INSTALLER	Used for installing taper roller bearing of front differential.

# GENERAL DESCRIPTION

Automatic Transmission

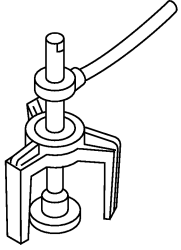
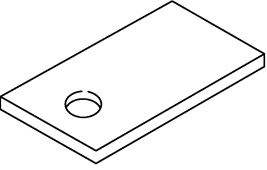
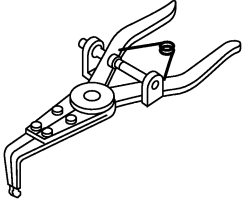
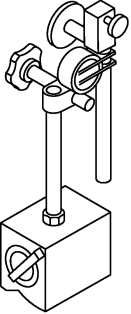
ILLUSTRATION	TOOL NUMBER	DESCRIPTION	REMARKS
 <p style="text-align: center;">B3M2002</p>	398673600	COMPRESSOR	Used for removing and installing clutch spring.
 <p style="text-align: center;">B3M1973</p>	498255400	PLATE	Used for measuring backlash of hypoid gear.
 <p style="text-align: center;">B3M2003</p>	399893600	PLIERS	Used for removing and installing clutch spring.
 <p style="text-align: center;">B3M1945</p>	498247001	MAGNET BASE	<ul style="list-style-type: none"> <li>● Used for measuring gear backlash.</li> <li>● Used with DIAL GAUGE (498247100).</li> </ul>

# GENERAL DESCRIPTION

Automatic Transmission

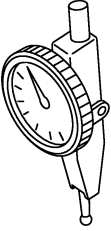
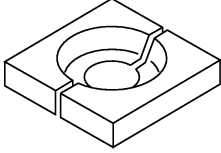
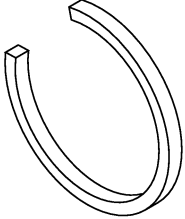
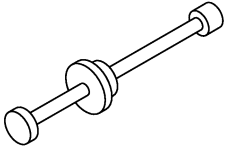
ILLUSTRATION	TOOL NUMBER	DESCRIPTION	REMARKS
 <p>B3M1946</p>	498247100	DIAL GAUGE	<ul style="list-style-type: none"> <li>• Used for measuring gear backlash.</li> <li>• Used with MAGNET BASE (498247001).</li> </ul>
 <p>B3M2004</p>	498517000	REPLACER	Used for removing front roller bearing.
 <p>B3M2005</p>	498627100	SEAT	Used for removing spring of transfer clutch piston.
 <p>B3M2006</p>	499095500	REMOVER	Used for removing axle shaft.

# GENERAL DESCRIPTION

Automatic Transmission

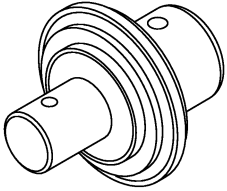
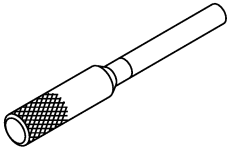
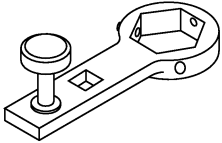
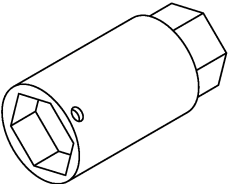
ILLUSTRATION	TOOL NUMBER	DESCRIPTION	REMARKS
 <p style="text-align: center;">B3M2007</p>	499247300	INSTALLER	<ul style="list-style-type: none"> <li>● Used for removing axle shaft.</li> <li>● Used with REMOVER (499095500).</li> </ul>
 <p style="text-align: center;">B3M2008</p>	499267300	STOPPER PIN	Used for installing inhibitor switch.
 <p style="text-align: center;">B3M2009</p>	499787700	WRENCH	Used for removing and installing drive pinion lock nut.
 <p style="text-align: center;">B3M2010</p>	499787500	ADAPTER	Used for removing and installing drive pinion lock nut.

# GENERAL DESCRIPTION

Automatic Transmission

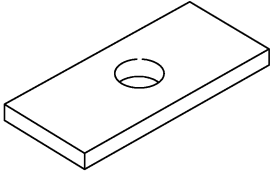
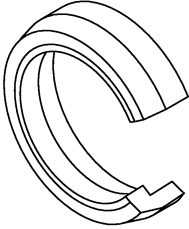
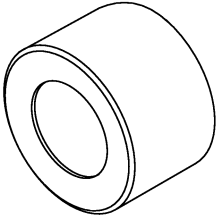
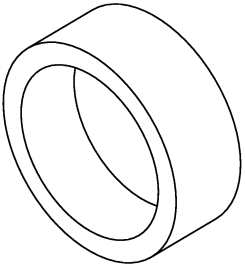
ILLUSTRATION	TOOL NUMBER	DESCRIPTION	REMARKS
 <p style="text-align: center;">B3M1978</p>	398643600	GAUGE	Used for measuring total end play, extension end play and drive pinion height.
 <p style="text-align: center;">B3M2011</p>	498627100	SEAT	Used for holding low clutch piston retainer spring when installing snap ring.
 <p style="text-align: center;">B3M2012</p>	499577000	GAUGE	<ul style="list-style-type: none"> <li>● Used for measuring the transmission case mating surface to the reduction gear end surface.</li> <li>● For without VTD.</li> </ul>
 <p style="text-align: center;">B2M3854</p>	398744300	GAUGE	<ul style="list-style-type: none"> <li>● Used for measuring the transmission case mating surface to the multi-plate clutch end surface.</li> <li>● For with VTD.</li> </ul>

# GENERAL DESCRIPTION

Automatic Transmission

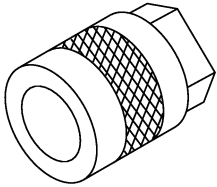
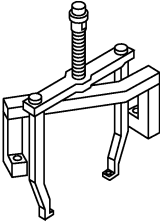
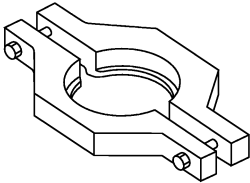
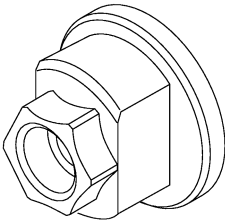
ILLUSTRATION	TOOL NUMBER	DESCRIPTION	REMARKS
 <p style="text-align: center;">B3M2013</p>	499737000	PULLER	Used for removing reduction driven gear assembly.
 <p style="text-align: center;">B3M2014</p>	499737100	PULLER SET	Used for removing reduction drive gear assembly.
 <p style="text-align: center;">B3M2015</p>	498077600	REMOVER	Used for removing ball bearing.
 <p style="text-align: center;">B3M2016</p>	498937110	HOLDER	Used for removing and installing drive pinion lock nut.

# GENERAL DESCRIPTION

Automatic Transmission

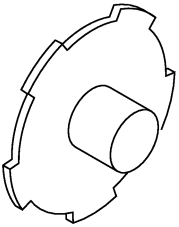
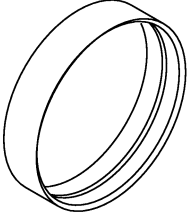
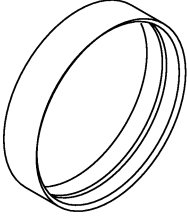
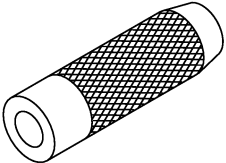
ILLUSTRATION	TOOL NUMBER	DESCRIPTION	REMARKS
 <p style="text-align: center;">B3M2017</p>	498677100	COMPRESSOR	Used for installing 2-4 brake snap ring.
 <p style="text-align: center;">B3M2018</p>	498437000	HIGH CLUTCH PISTON GUIDE	Used for installing high clutch piston.
 <p style="text-align: center;">B3M2018</p>	498437100	LOW CLUTCH PISTON GUIDE	Used for installing low clutch piston.
 <p style="text-align: center;">B3M2019</p>	899580100	INSTALLER	Used for press-fitting the ball bearing for transfer clutch.



# GENERAL DESCRIPTION

Automatic Transmission

## 2. GENERAL PURPOSE TOOLS SS10001A1702

TOOL NAME	REMARKS
Depth gauge	Used for measuring transmission end play.
Thickness gauge	Used for measuring clearances of clutch, brake and oil pump.
Micro meter	Used for measuring thickness of drive pinion.
Spring balance	Used for measuring starting torque of drive pinion.

## E: PROCEDURE SS10001E45

- In this section the procedures described under each index are all connected and stated in order. It will be the complete procedure for overhauling of the automatic transmission itself when you go through all steps in the process. Therefore, in this section, to conduct the particular procedure within the flow of a section, you need to go back and conduct the procedure described previously in order to do that particular procedure.

# GENERAL DESCRIPTION

Automatic Transmission

## 1. General Description S510001

### A: SPECIFICATIONS S510001E49

#### 1. DRIVE PLATE AND DRIVEN PLATE S510001E4901

Plate number of high clutch	1.6 L	3
	2.0 L	4
	2.0 L TURBO	5
	2.5 L	4
	3.0 L	5
Plate number of reverse clutch	1.6 L	1
	2.0 L	2
	2.0 L TURBO	2
	2.5 L	2
	3.0 L	2
Plate number of 2-4 brake	1.6 L	2
	2.0 L	3
	2.0 L TURBO	4
	2.5 L	3
	3.0 L	4
Plate number of low clutch	1.6 L	4
	2.0 L	4
	2.0 L TURBO	7
	2.5 L	6
	3.0 L	7
Plate number of low and reverse brake	1.6 L	4
	2.0 L	4
	2.0 L TURBO	7
	2.5 L	6
	3.0 L	7
Plate number of transfer clutch	1.6 L	4
	2.0 L	4
	2.0 L TURBO (Without VTD)	6
	2.0 L TURBO (With VTD)	3
	2.5 L (Without VTD)	5
	2.5 L (With VTD)	3
	3.0 L (Without VTD)	6
	3.0 L (With VTD)	3

## 2. AUTOMATIC TRANSMISSION FLUID CAPACITY S510001E4902

Dexron III type Automatic transmission fluid	
1.6 L, 2.0 L	8.4 — 8.7 ℓ (8.9 — 9.2 US qt, 7.4 — 7.7 Imp qt)
2.0 L TURBO, 2.5 L, 3.0 L	9.3 — 9.6 ℓ (9.8 — 10.1 US qt, 8.2 — 8.4 Imp qt)

## 3. FRONT DIFFERENTIAL OIL CAPACITY S510001E4903

Recommended oil	Oil capacity
GL-5	1.1 — 1.2 ℓ (1.2 — 1.3 US qt, 1.0 — 1.1 Imp qt)

# GENERAL DESCRIPTION

Automatic Transmission

---

MEMO:



## 2. OIL PUMP SS10001A0502

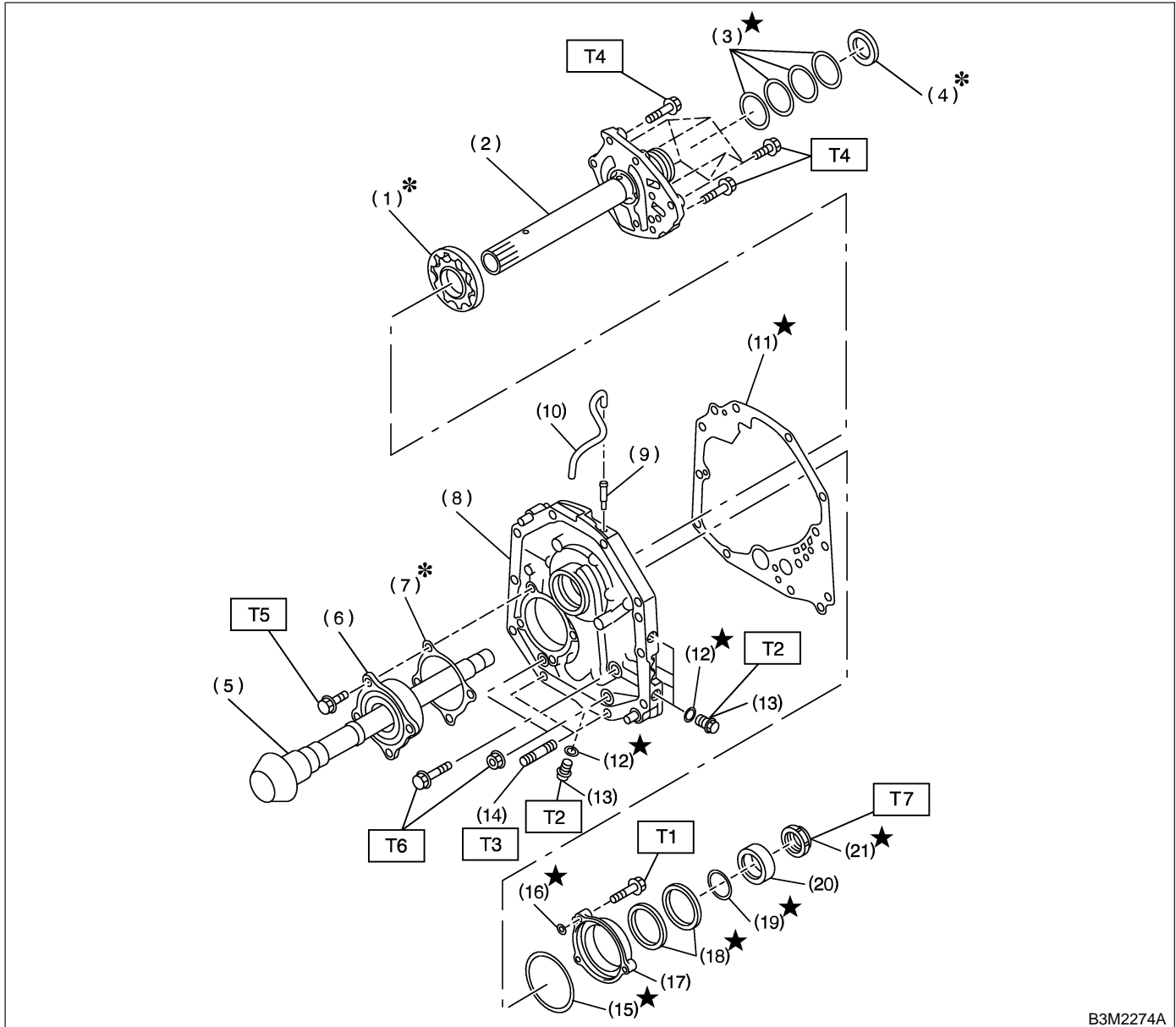

B3M2274A

- |                           |                          |
|---------------------------|--------------------------|
| (1) Oil pump rotor        | (12) O-ring              |
| (2) Oil pump cover        | (13) Test plug           |
| (3) Seal ring             | (14) Stud bolt           |
| (4) Thrust needle bearing | (15) O-ring              |
| (5) Drive pinion shaft    | (16) O-ring              |
| (6) Roller bearing        | (17) Oil seal retainer   |
| (7) Shim                  | (18) Oil seal            |
| (8) Oil pump housing      | (19) O-ring              |
| (9) Nipple                | (20) Drive pinion collar |
| (10) Air breather hose    | (21) Lock nut            |
| (11) Gasket               |                          |

**Tightening torque: N·m (kgf·m, ft·lb)**

**T1: 7 (0.7, 5.1)**

**T2: 13 (1.3, 9.4)**

**T3: 18 (1.8, 13.0)**

**T4: 25 (2.5, 18.1)**

**T5: 40 (4.1, 30)**

**T6: 42 (4.3, 31)**

**T7: 116 (11.8, 85)**

# GENERAL DESCRIPTION

Automatic Transmission

## 3. TRANSMISSION CASE AND CONTROL DEVICE

SS10001A0503

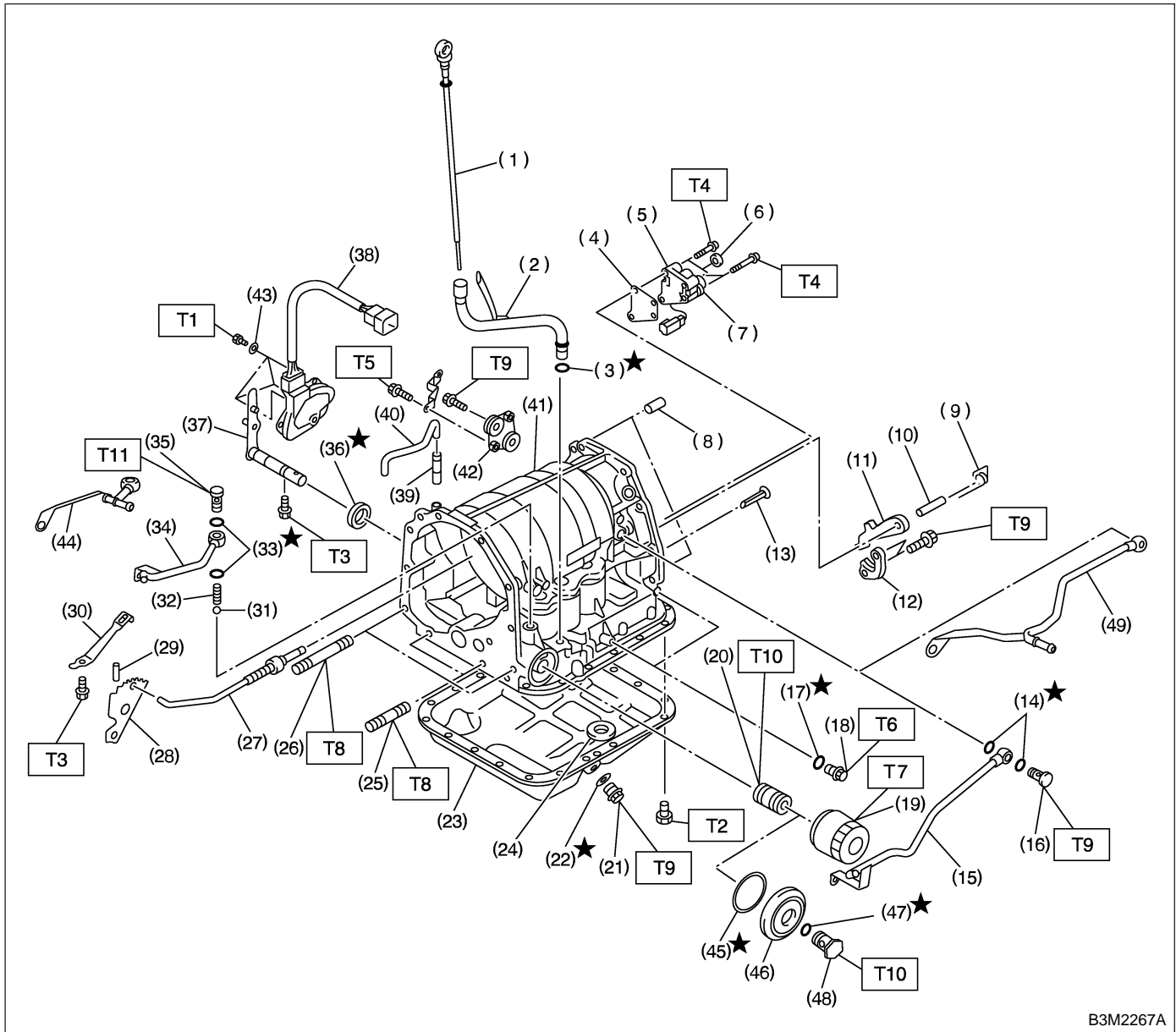

B3M2267A

# GENERAL DESCRIPTION

Automatic Transmission

---

(1) ATF level gauge	(22) Gasket	(43) Washer
(2) ATF charger pipe	(23) Oil pan	(44) Outlet pipe (Except for Forester)
(3) O-ring	(24) Magnet	(45) O-ring (3.0 L model)
(4) Transfer valve plate	(25) Stud bolt (Short)	(46) Cover (3.0 L model)
(5) Transfer valve ASSY	(26) Stud bolt (Long)	(47) Gasket (3.0 L model)
(6) Transfer clutch seal	(27) Parking rod	(48) Union screw (3.0 L model)
(7) Transfer duty solenoid	(28) Manual plate	(49) Inlet pipe (Except for Forester)
(8) Straight pin	(29) Spring pin	
(9) Return spring	(30) Detention spring	<b><i>Tightening torque: N·m (kgf·m, ft·lb)</i></b>
(10) Shaft	(31) Ball	<b><i>T1: 3.4 (0.35, 2.5)</i></b>
(11) Parking pawl	(32) Spring	<b><i>T2: 5 (0.5, 3.6)</i></b>
(12) Parking support	(33) Gasket	<b><i>T3: 6 (0.6, 4)</i></b>
(13) Inlet filter	(34) Outlet pipe (For Forester)	<b><i>T4: 8 (0.8, 6)</i></b>
(14) Gasket	(35) Union screw	<b><i>T5: 12 (1.2, 8.7)</i></b>
(15) Inlet pipe (Except for Forester)	(36) Oil seal	<b><i>T6: 13 (1.3, 10)</i></b>
(16) Union screw	(37) Select lever	<b><i>T7: 14 (1.4, 10)</i></b>
(17) O-ring	(38) Inhibitor switch ASSY	<b><i>T8: 18 (1.8, 13)</i></b>
(18) Test plug	(39) Nipple	<b><i>T9: 25 (2.6, 18)</i></b>
(19) Oil filter (Except 3.0 L model)	(40) Air breather hose	<b><i>T10: 44 (4.5, 32)</i></b>
(20) Oil filter stud bolt	(41) Transmission case	
(21) Drain plug	(42) Plate ASSY	

---

# GENERAL DESCRIPTION

Automatic Transmission

## 4. CONTROL VALVE AND HARNESS ROUTING

SS10001A0504

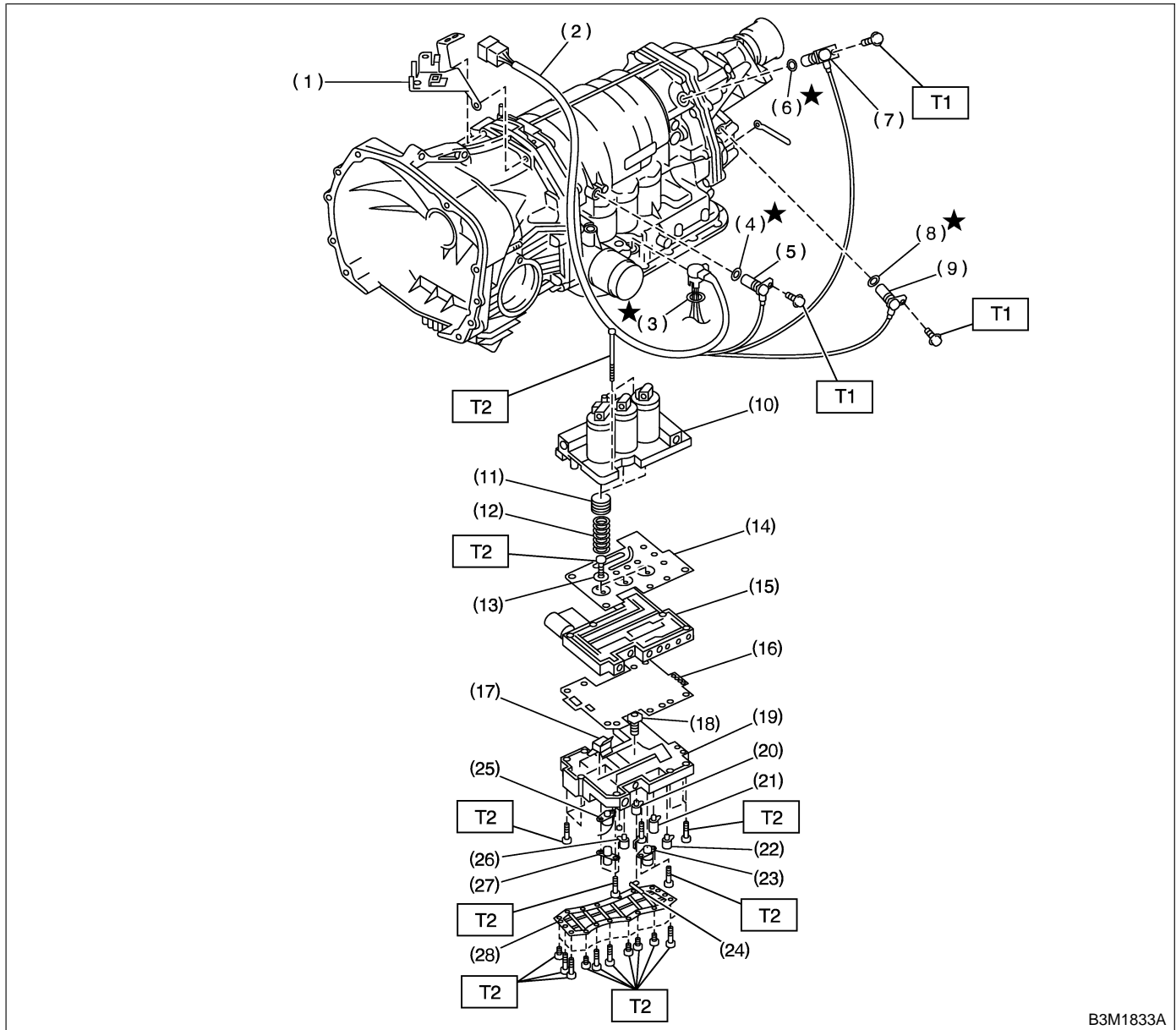

B3M1833A

- (1) Stay
- (2) Transmission harness
- (3) O-ring
- (4) O-ring
- (5) Torque converter turbine speed sensor
- (6) O-ring
- (7) Front vehicle speed sensor
- (8) O-ring
- (9) Rear vehicle speed sensor
- (10) Upper valve body
- (11) Accumulator piston

- (12) Accumulator spring
- (13) Side plate
- (14) Separate plate
- (15) Middle valve body
- (16) Separate plate
- (17) Fluid filter
- (18) Fluid filter
- (19) Lower valve body
- (20) Shift solenoid 2
- (21) Shift solenoid 1
- (22) 2-4 brake timing solenoid
- (23) 2-4 brake duty solenoid

- (24) ATF temperature sensor
- (25) Line pressure duty solenoid
- (26) Low clutch timing solenoid
- (27) Lock-up duty solenoid
- (28) Oil strainer

**Tightening torque: N·m (kgf·m, ft·lb)**

**T1: 7 (0.7, 5.1)**

**T2: 8 (0.8, 5.8)**



## 5. HIGH CLUTCH AND REVERSE CLUTCH

S510001A0505

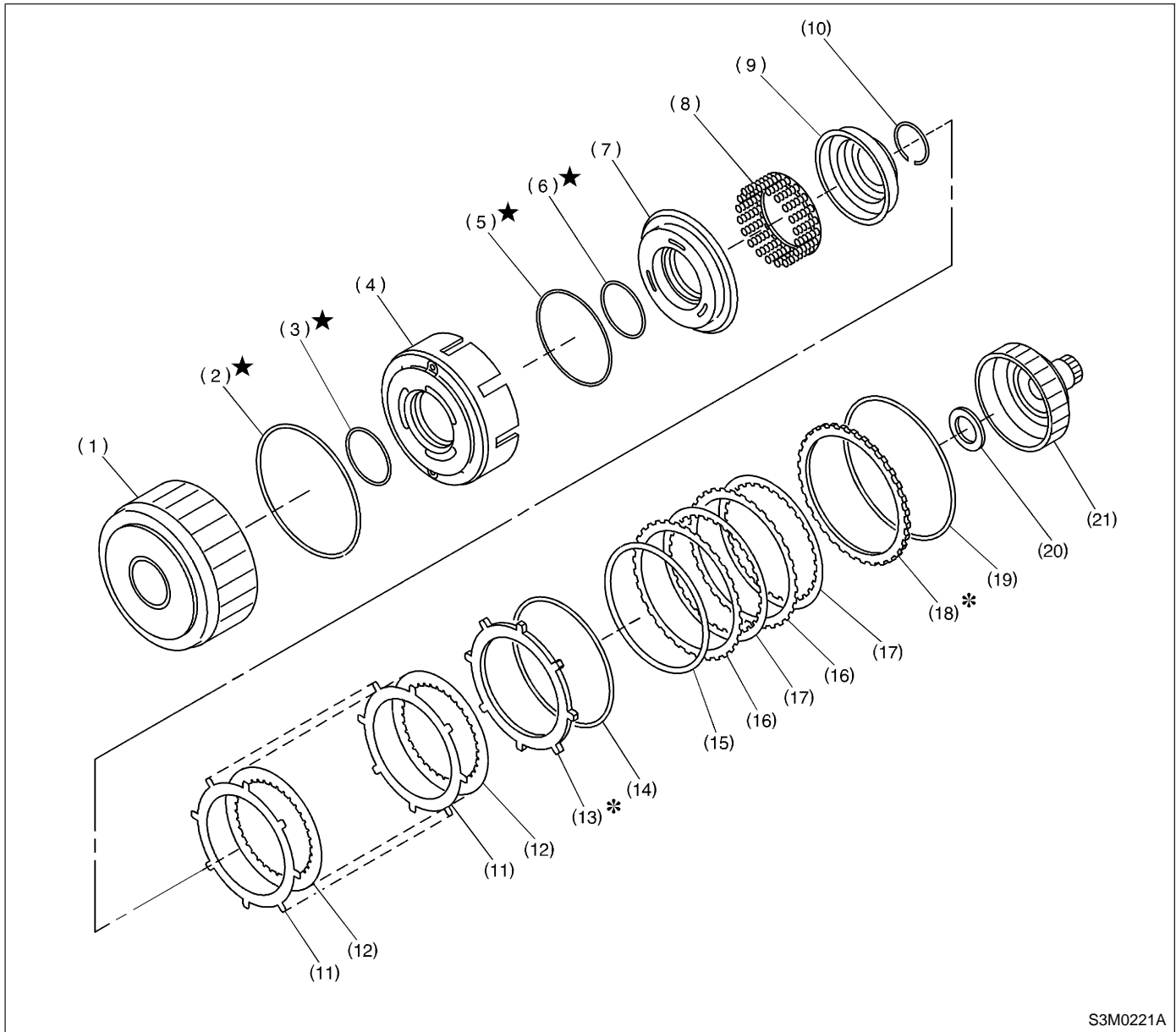

S3M0221A

- |                           |                      |                            |
|---------------------------|----------------------|----------------------------|
| (1) High clutch drum      | (8) Spring retainer  | (15) Dish plate            |
| (2) Lip seal              | (9) Cover            | (16) Driven plate          |
| (3) Lathe cut seal ring   | (10) Snap ring       | (17) Drive plate           |
| (4) Reverse clutch piston | (11) Driven plate    | (18) Retaining plate       |
| (5) Lathe cut seal ring   | (12) Drive plate     | (19) Snap ring             |
| (6) Lathe cut seal ring   | (13) Retaining plate | (20) Thrust needle bearing |
| (7) High clutch piston    | (14) Snap ring       | (21) High clutch hub       |

# GENERAL DESCRIPTION

Automatic Transmission

## 6. PLANETARY GEAR AND 2-4 BRAKE

S510001A0506

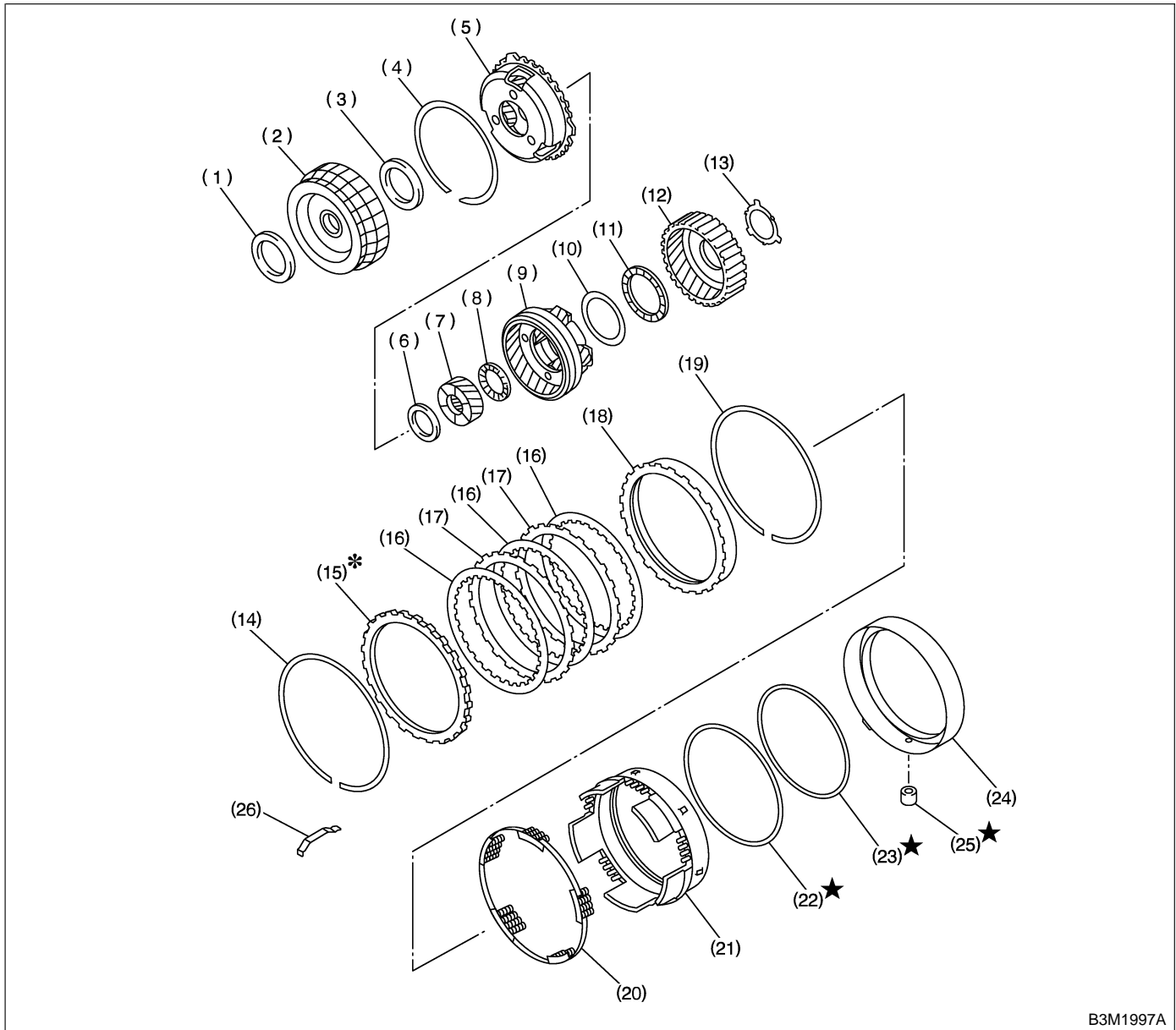

B3M1997A

- |                             |                            |                                |
|-----------------------------|----------------------------|--------------------------------|
| (1) Thrust needle bearing   | (10) Washer                | (19) Snap ring                 |
| (2) Front sun gear          | (11) Thrust needle bearing | (20) Spring retainer           |
| (3) Thrust needle bearing   | (12) Rear internal gear    | (21) 2-4 brake piston          |
| (4) Snap ring               | (13) Washer                | (22) Lathe cut seal ring       |
| (5) Front planetary carrier | (14) Snap ring             | (23) Lathe cut seal ring       |
| (6) Thrust needle bearing   | (15) Retaining plate       | (24) 2-4 brake piston retainer |
| (7) Rear sun gear           | (16) Drive plate           | (25) 2-4 brake seal            |
| (8) Thrust needle bearing   | (17) Driven plate          | (26) Leaf spring               |
| (9) Rear planetary carrier  | (18) Pressure rear plate   |                                |

## 7. LOW CLUTCH AND LOW & REVERSE BRAKE

SS10001A0507

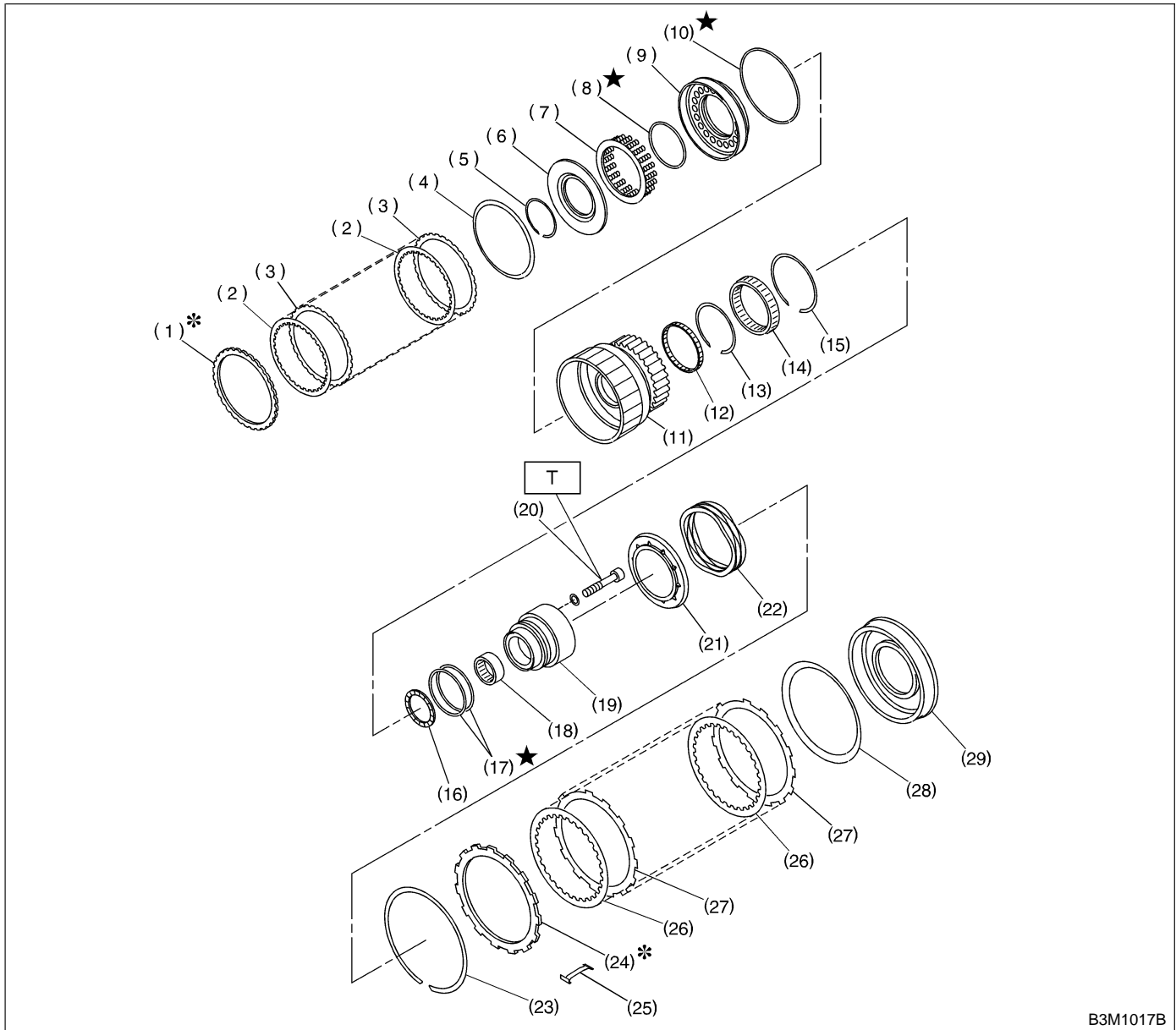

B3M1017B

- |                          |                                |                                   |
|--------------------------|--------------------------------|-----------------------------------|
| (1) Retaining plate      | (12) Needle bearing            | (23) Snap ring                    |
| (2) Drive plate          | (13) Inner snap ring           | (24) Retaining plate              |
| (3) Driven plate         | (14) One-way clutch            | (25) Leaf spring                  |
| (4) Dish plate           | (15) Outer snap ring           | (26) Drive plate                  |
| (5) Snap ring            | (16) Thrust needle bearing     | (27) Driven plate                 |
| (6) Cover                | (17) Seal ring                 | (28) Dish plate                   |
| (7) Spring retainer      | (18) Needle bearing            | (29) Low and reverse brake piston |
| (8) Lathe cut seal ring  | (19) One-way clutch inner race |                                   |
| (9) Low clutch piston    | (20) Socket bolt               |                                   |
| (10) Lathe cut seal ring | (21) Spring retainer           |                                   |
| (11) Low clutch drum     | (22) Return spring             |                                   |

**Tightening torque: N·m (kgf·m, ft·lb)**  
**T: 25 (2.5, 18.1)**

# GENERAL DESCRIPTION

Automatic Transmission

## 8. REDUCTION GEAR WITHOUT VTD

S510001A0508

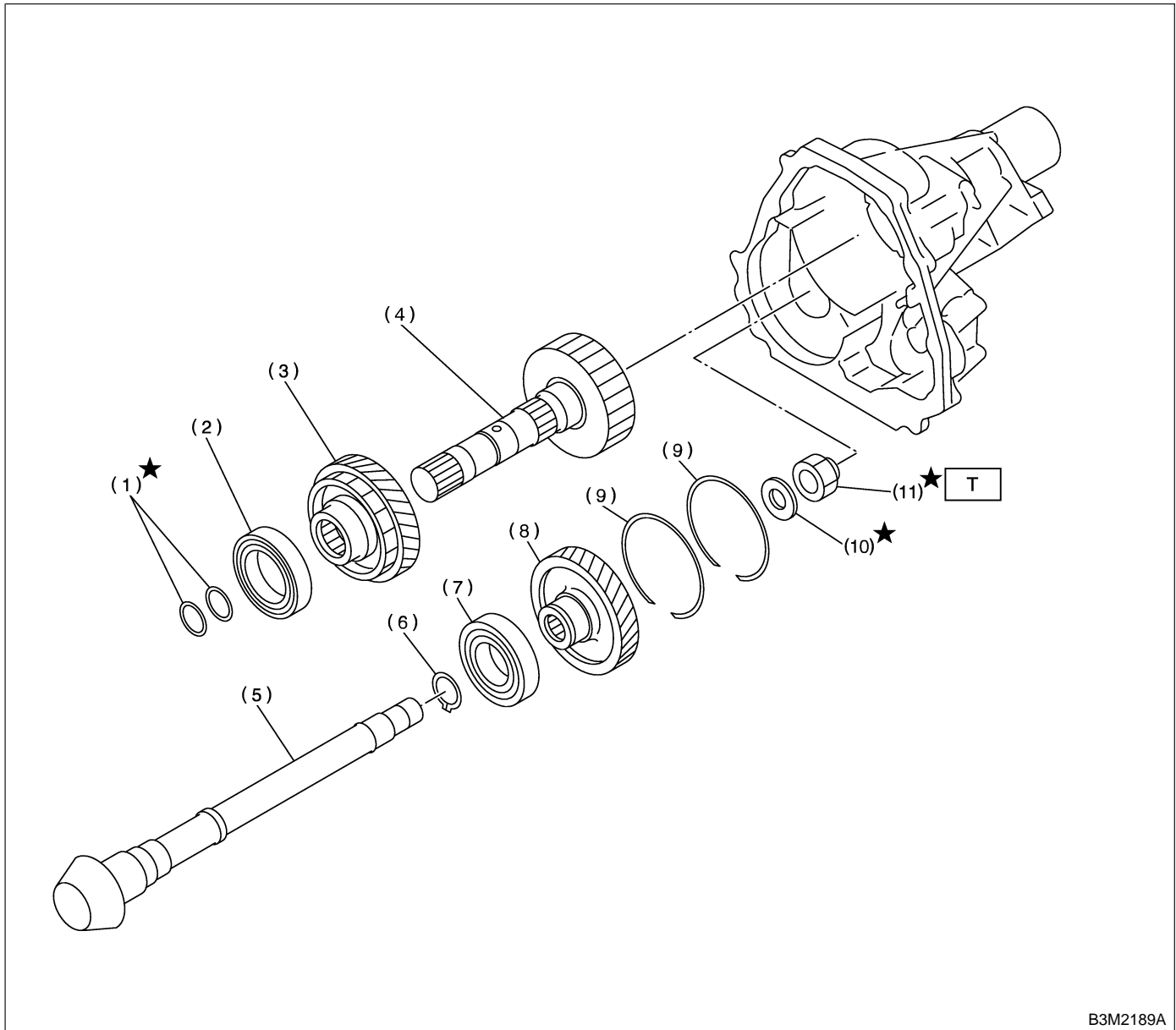

B3M2189A

- (1) Seal ring
- (2) Ball bearing
- (3) Reduction drive gear
- (4) Reduction drive shaft
- (5) Drive pinion shaft

- (6) Snap ring
- (7) Ball bearing
- (8) Reduction driven gear
- (9) Snap ring (Legacy 2.5 L US model and 3.0 L model)

- (10) Washer
- (11) Lock nut

**Tightening torque: N·m (kgf·m, ft·lb)**  
**T: 100 (10.2, 73.8)**

## 9. REDUCTION GEAR WITH VTD S510001A0509

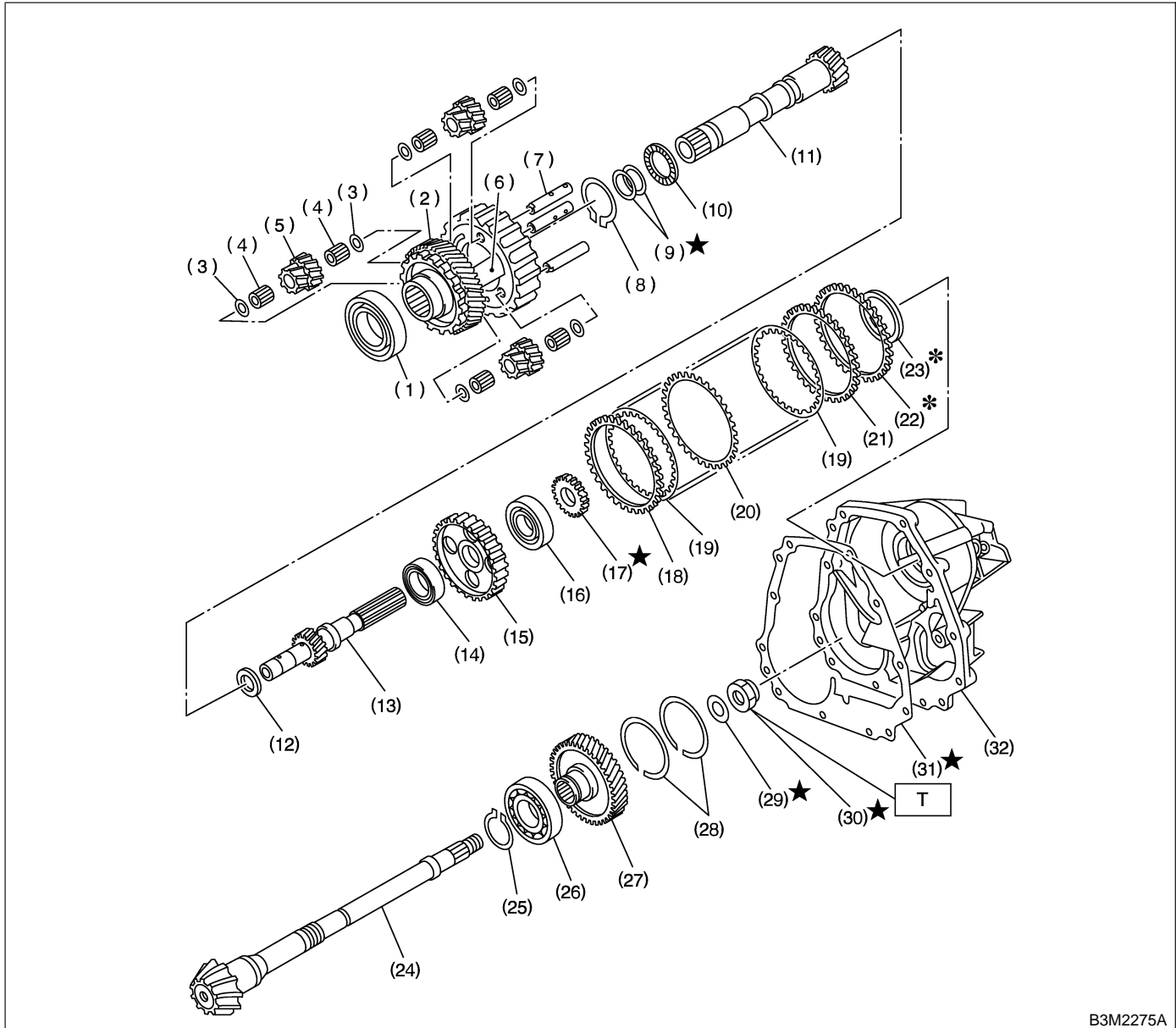

B3M2275A

- |                            |                                   |  |
|----------------------------|-----------------------------------|--|
| (1) Ball bearing           | (14) Ball bearing                 | (27) Reduction driven gear                             |
| (2) Reduction drive gear   | (15) Multi-plate clutch (LSD) hub | (28) Snap ring (Legacy 2.5 L US model and 3.0 L model) |
| (3) Washer                 | (16) Ball bearing                 | (29) Lock washer                                       |
| (4) Needle bearing         | (17) Revolution gear              | (30) Lock nut  |
| (5) Pinion gear            | (18) Driven plate (Thicker)       | (31) Gasket  |
| (6) Carrier                | (19) Drive plate                  | (32) Extension case                                    |
| (7) Planetary pinion shaft | (20) Driven plate (Thinner)       |  |
| (8) Snap ring              | (21) Driven plate (Thicker)       |  |
| (9) Seal ring              | (22) Adjust plate                 |  |
| (10) Thrust needle bearing | (23) Rear drive shaft shim        |  |
| (11) Intermediate shaft    | (24) Drive pinion shaft           |  |
| (12) Thrust washer         | (25) Snap ring                    |  |
| (13) Rear drive shaft      | (26) Ball bearing                 |  |

**Tightening torque: N·m (kgf·m, ft·lb)**  
**T: 100 (10.2, 73.8)**

# GENERAL DESCRIPTION

Automatic Transmission

## 10. DIFFERENTIAL GEAR S510001A0510

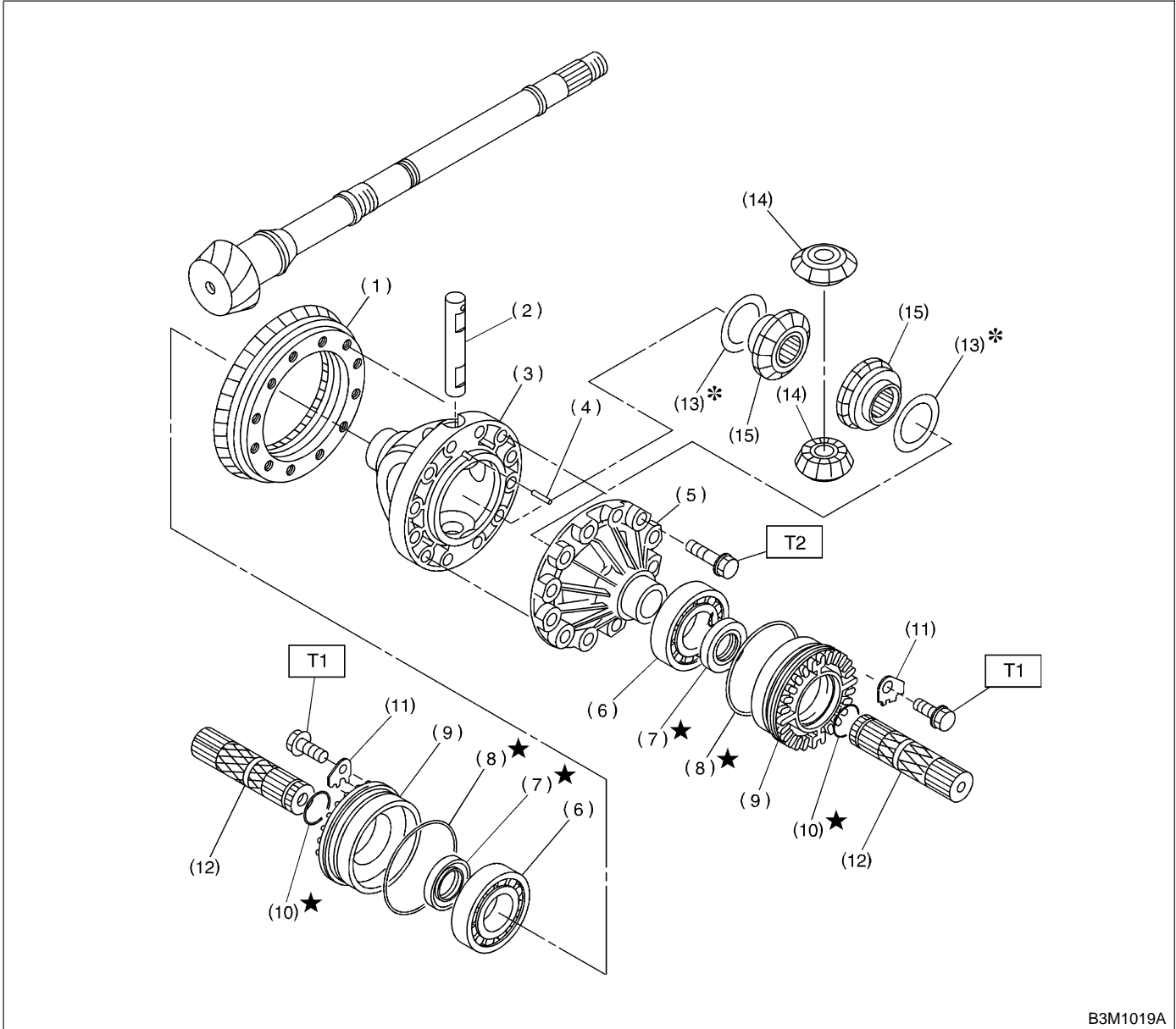

B3M1019A

- |                            |                                |
|----------------------------|--------------------------------|
| (1) Crown gear             | (8) O-ring                     |
| (2) Pinion shaft           | (9) Differential side retainer |
| (3) Differential case (RH) | (10) Circlip                   |
| (4) Straight pin           | (11) Lock plate                |
| (5) Differential case (LH) | (12) Axle shaft                |
| (6) Taper roller bearing   | (13) Washer                    |
| (7) Oil seal               | (14) Differential bevel pinion |

- (15) Differential bevel gear

**Tightening torque: N·m (kgf·m, ft·lb)**

**T1: 25 (2.5, 18.1)**

**T2: 62 (6.3, 45.6)**

## 11. TRANSFER AND EXTENSION CASE WITHOUT VTD

SS10001A0511

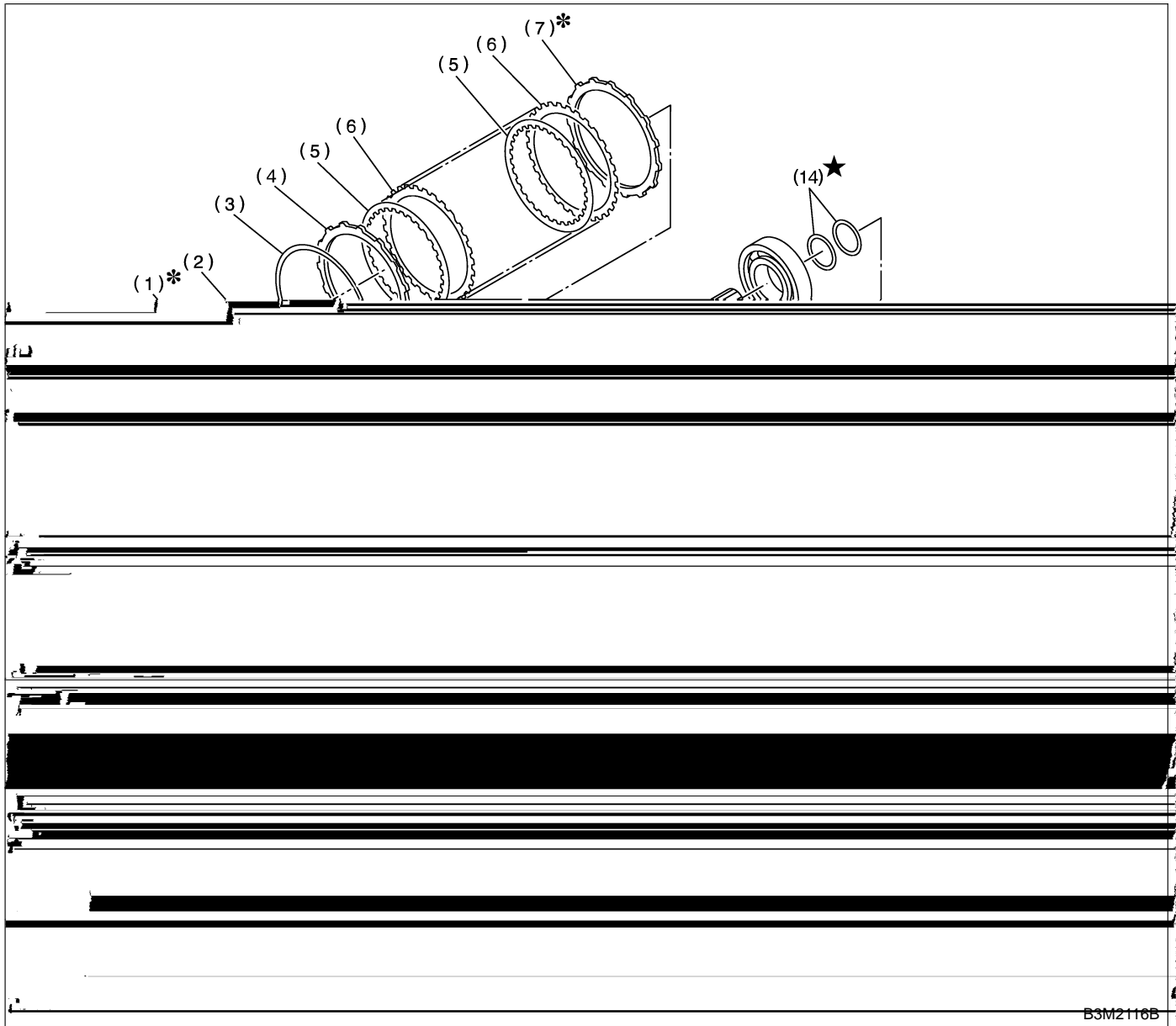

B3M2116B

- (1) Thrust needle bearing
- (2) Needle bearing
- (3) Snap ring
- (4) Pressure plate
- (5) Drive plate
- (6) Driven plate
- (7) Pressure plate
- (8) Snap ring
- (9) Transfer piston seal
- (10) Return spring

- (11) Transfer clutch piston
- (12) Rear drive shaft
- (13) Ball bearing
- (14) Seal ring
- (15) Gasket
- (16) Transfer clutch pipe
- (17) Extension case
- (18) Transmission hanger
- (19) Oil seal
- (20) Dust cover

- (21) Test plug
- (22) O-ring
- (23) Clip

**Tightening torque: N·m (kgf·m, ft·lb)**

**T1: 13 (1.3, 9.4)**

**T2: 25 (2.5, 18.1)**

# GENERAL DESCRIPTION

Automatic Transmission

## 12. TRANSFER AND EXTENSION CASE WITH VTD

S510001A0512

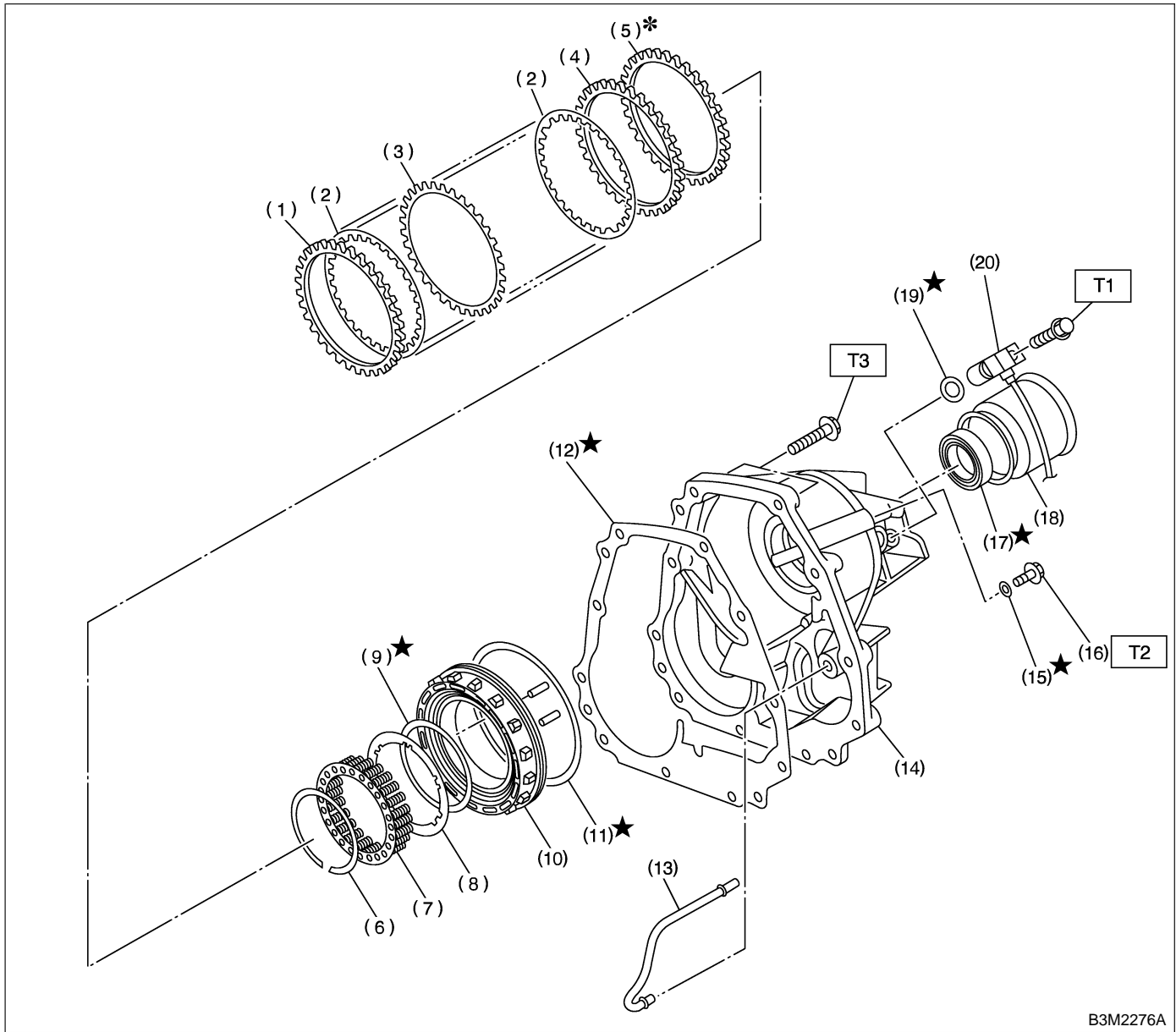

B3M2276A

- (1) Driven plate (Thicker)
- (2) Drive plate
- (3) Driven plate (Thinner)
- (4) Driven plate (Thicker)
- (5) Adjust plate
- (6) Snap ring
- (7) Spring retainer
- (8) Plate
- (9) Lathe cut seal ring

- (10) Multi-plate clutch (LSD) piston ASSY
- (11) Lathe cut seal ring
- (12) Gasket
- (13) Multi-plate clutch (LSD) pipe
- (14) Extension case
- (15) O-ring
- (16) Test plug
- (17) Oil seal

- (18) Dust cover
- (19) O-ring
- (20) Rear vehicle speed sensor

**Tightening torque: N·m (kgf·m, ft·lb)**

**T1: 7 (0.7, 5.1)**

**T2: 13 (1.3, 9.4)**

**T3: 25 (2.5, 18.1)**



**C: PRECAUTION** SS10001F59

When disassembling or assembling the automatic transmission, observe the following instructions.

**1) Workshop**

Provide a place that is clean and free from dust. Principally the conventional workshop is suitable except for a dusty place. In a workshop where grinding work, etc. which produces fine particles is done, make independent place divided by the vinyl curtain or the equivalent.

**2) Work table**

The size of 1 x 1.5 m (40 x 60 in) is large enough to work, and it is more desirable that its surface be covered with flat plate like iron plate which is not rusted too much.

**3) Cleaning of exterior**

(1) Clean the exterior surface of transmission with steam and/or kerosene prior to disassembly, however it should be noted that vinyl tape be placed on the air breather or oil level gauge to prevent infiltration of the steam into the transmission and also the cleaning job be done away from the place of disassembly and assembly.

(2) Partial cleaning will do, depending on the extent of disassembly (such as when disassembly is limited to some certain parts).

**4) Disassembly, assembly and cleaning**

(1) Disassemble and assemble the transmission while inspecting the parts in accordance with the Diagnostics.

(2) During job, do not use gloves. Do not clean the parts with rags: Use chamois or nylon cloth.

(3) Pay special attention to the air to be used for cleaning. Get the moisture and the dust rid of the air as much as possible. Be careful not to scratch or dent any part while checking for proper operation with an air gun.

(4) Complete the job from cleaning to completion of assembly as continuously and speedily as possible in order to avoid occurrence of secondary troubles caused by dust. When stopping the job unavoidably cover the parts with clean chamois or nylon cloth to keep them away from any dust.

(5) Use kerosene, white gasoline or the equivalent as washing fluid. Use always new fluid for cleaning the automatic transmission parts and never reuse. The used fluid is usable in disassemble and assemble work of engine and manual transmission.

(6) Although the cleaning should be done by dipping into the washing fluid or blowing of the pressurized washing fluid, the dipping is more desirable. (Do not rub with a brush.) Assemble the parts immediately after the cleaning without exposure to the air for a while. Besides in case

of washing rubber parts, perform the job quickly not to dip them into the washing fluid for long time.

(7) Apply the automatic transmission fluid (ATF) onto the parts immediately prior to assembly, and the specified tightening torque should be observed carefully.

(8) Use vaseline if it is necessary to hold parts in the position when assembling.

(9) Drain ATF and differential gear oil into a saucer so that the conditions of fluid and oil can be inspected.

(10) Do not support axle drive shaft, stator shaft, input shaft or various pipes when moving transmission from one place to another.

(11) Always discard old oil seals and O-ring, and install new ones.

(12) Be sure to replace parts which are damaged, worn, scratched, discolored, etc.

# GENERAL DESCRIPTION

Automatic Transmission

## D: PREPARATION TOOL S510001A17

### 1. SPECIAL TOOLS S510001A1701

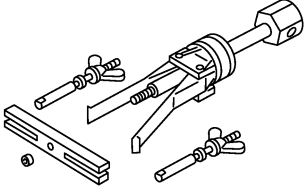
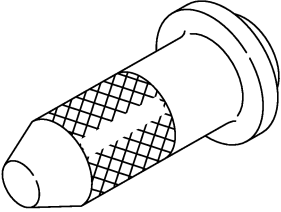
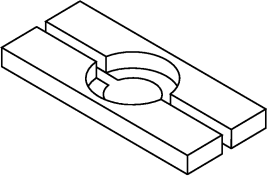
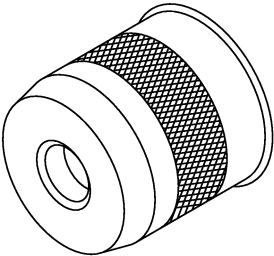
ILLUSTRATION	TOOL NUMBER	DESCRIPTION	REMARKS
 <p>B3M1977</p>	398527700	PULLER ASSY	<ul style="list-style-type: none"> <li>Used for removing extension case roller bearing.</li> <li>Used for removing extension oil seal.</li> <li>Used for removing front differential side retainer bearing outer race.</li> </ul>
 <p>B3M1972</p>	498057300	INSTALLER	Used for installing extension oil seal.
 <p>B3M1998</p>	498077000	REMOVER	Used for removing differential taper roller bearing.
 <p>B3M1999</p>	499247400	INSTALLER	<ul style="list-style-type: none"> <li>Used for installing transfer outer snap ring.</li> <li>Used with GUIDE (499257300).</li> </ul>

# GENERAL DESCRIPTION

Automatic Transmission

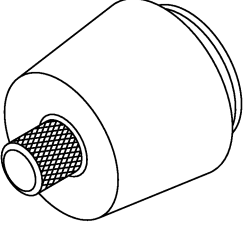
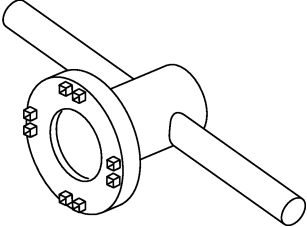
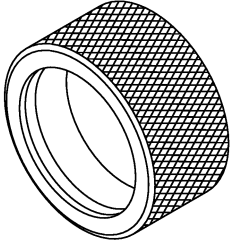
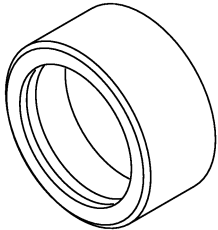
ILLUSTRATION	TOOL NUMBER	DESCRIPTION	REMARKS
 <p>B3M2000</p>	499257300	SNAP RING OUTER GUIDE	<ul style="list-style-type: none"> <li>• Used for installing transfer outer snap ring.</li> <li>• Used with INSTALLER (499247400).</li> </ul>
 <p>B3M1953</p>	499787000	WRENCH ASSY	Used for removing and installing differential side retainer.
 <p>B3M2001</p>	398437700	DRIFT	Used for installing converter case oil seal.
 <p>B3M1912</p>	398487700	INSTALLER	Used for installing taper roller bearing of front differential.

# GENERAL DESCRIPTION

Automatic Transmission

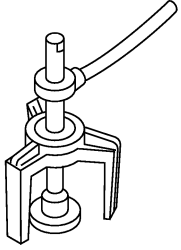
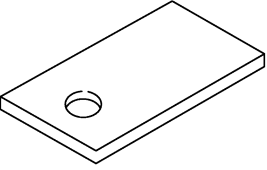
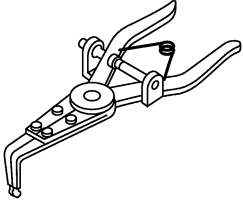
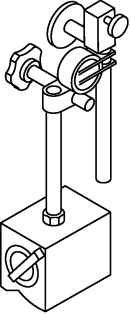
ILLUSTRATION	TOOL NUMBER	DESCRIPTION	REMARKS
 <p style="text-align: center;">B3M2002</p>	398673600	COMPRESSOR	Used for removing and installing clutch spring.
 <p style="text-align: center;">B3M1973</p>	498255400	PLATE	Used for measuring backlash of hypoid gear.
 <p style="text-align: center;">B3M2003</p>	399893600	PLIERS	Used for removing and installing clutch spring.
 <p style="text-align: center;">B3M1945</p>	498247001	MAGNET BASE	<ul style="list-style-type: none"> <li>● Used for measuring gear backlash.</li> <li>● Used with DIAL GAUGE (498247100).</li> </ul>

# GENERAL DESCRIPTION

Automatic Transmission

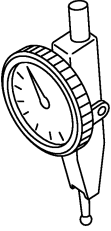
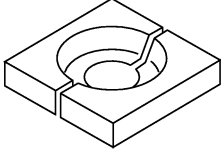
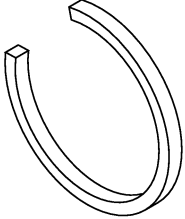
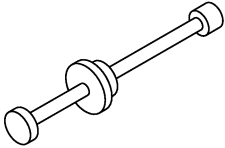
ILLUSTRATION	TOOL NUMBER	DESCRIPTION	REMARKS
 <p>B3M1946</p>	498247100	DIAL GAUGE	<ul style="list-style-type: none"> <li>• Used for measuring gear backlash.</li> <li>• Used with MAGNET BASE (498247001).</li> </ul>
 <p>B3M2004</p>	498517000	REPLACER	Used for removing front roller bearing.
 <p>B3M2005</p>	498627100	SEAT	Used for removing spring of transfer clutch piston.
 <p>B3M2006</p>	499095500	REMOVER	Used for removing axle shaft.

# GENERAL DESCRIPTION

Automatic Transmission

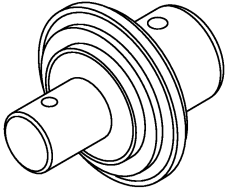
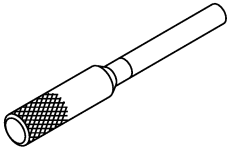
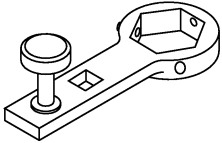
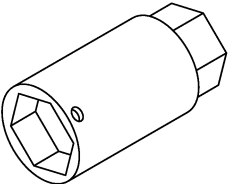
ILLUSTRATION	TOOL NUMBER	DESCRIPTION	REMARKS
 <p style="text-align: center;">B3M2007</p>	499247300	INSTALLER	<ul style="list-style-type: none"> <li>● Used for removing axle shaft.</li> <li>● Used with REMOVER (499095500).</li> </ul>
 <p style="text-align: center;">B3M2008</p>	499267300	STOPPER PIN	Used for installing inhibitor switch.
 <p style="text-align: center;">B3M2009</p>	499787700	WRENCH	Used for removing and installing drive pinion lock nut.
 <p style="text-align: center;">B3M2010</p>	499787500	ADAPTER	Used for removing and installing drive pinion lock nut.

# GENERAL DESCRIPTION

Automatic Transmission

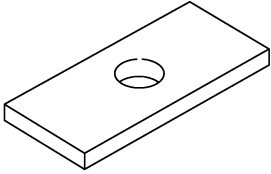
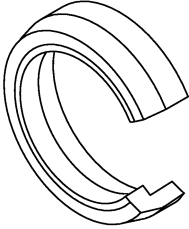
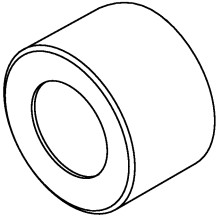
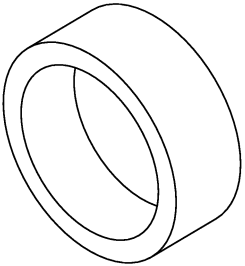
ILLUSTRATION	TOOL NUMBER	DESCRIPTION	REMARKS
 <p style="text-align: right;">B3M1978</p>	398643600	GAUGE	Used for measuring total end play, extension end play and drive pinion height.
 <p style="text-align: right;">B3M2011</p>	498627100	SEAT	Used for holding low clutch piston retainer spring when installing snap ring.
 <p style="text-align: right;">B3M2012</p>	499577000	GAUGE	<ul style="list-style-type: none"> <li>● Used for measuring the transmission case mating surface to the reduction gear end surface.</li> <li>● For without VTD.</li> </ul>
 <p style="text-align: right;">B2M3854</p>	398744300	GAUGE	<ul style="list-style-type: none"> <li>● Used for measuring the transmission case mating surface to the multi-plate clutch end surface.</li> <li>● For with VTD.</li> </ul>

# GENERAL DESCRIPTION

Automatic Transmission

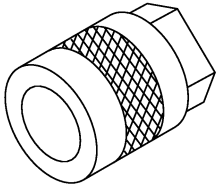
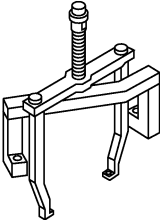
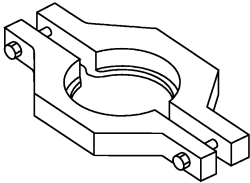
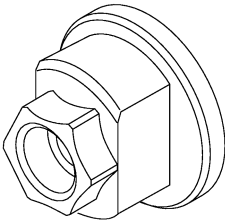
ILLUSTRATION	TOOL NUMBER	DESCRIPTION	REMARKS
 <p style="text-align: center;">B3M2013</p>	499737000	PULLER	Used for removing reduction driven gear assembly.
 <p style="text-align: center;">B3M2014</p>	499737100	PULLER SET	Used for removing reduction drive gear assembly.
 <p style="text-align: center;">B3M2015</p>	498077600	REMOVER	Used for removing ball bearing.
 <p style="text-align: center;">B3M2016</p>	498937110	HOLDER	Used for removing and installing drive pinion lock nut.



# GENERAL DESCRIPTION

Automatic Transmission

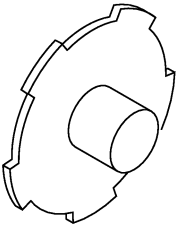
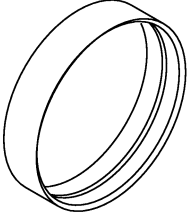
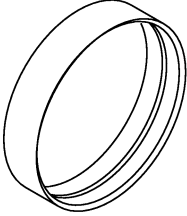
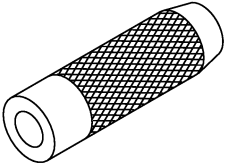
ILLUSTRATION	TOOL NUMBER	DESCRIPTION	REMARKS
 <p>B3M2017</p>	498677100	COMPRESSOR	Used for installing 2-4 brake snap ring.
 <p>B3M2018</p>	498437000	HIGH CLUTCH PISTON GUIDE	Used for installing high clutch piston.
 <p>B3M2018</p>	498437100	LOW CLUTCH PISTON GUIDE	Used for installing low clutch piston.
 <p>B3M2019</p>	899580100	INSTALLER	Used for press-fitting the ball bearing for transfer clutch.

# GENERAL DESCRIPTION

Automatic Transmission

## 2. GENERAL PURPOSE TOOLS SS10001A1702

TOOL NAME	REMARKS
Depth gauge	Used for measuring transmission end play.
Thickness gauge	Used for measuring clearances of clutch, brake and oil pump.
Micro meter	Used for measuring thickness of drive pinion.
Spring balance	Used for measuring starting torque of drive pinion.

## E: PROCEDURE SS10001E45

- In this section the procedures described under each index are all connected and stated in order. It will be the complete procedure for overhauling of the automatic transmission itself when you go through all steps in the process. Therefore, in this section, to conduct the particular procedure within the flow of a section, you need to go back and conduct the procedure described previously in order to do that particular procedure.

## 2. Automatic Transmission Assembly S510207

### A: NOTE S510207A15

For removal and installation procedures of automatic transmission, refer to “AT” sections for each model.

## 2. Automatic Transmission Assembly S510207

### A: NOTE S510207A15

For removal and installation procedures of automatic transmission, refer to “AT” sections for each model.

# AIR BREATHER HOSE

Automatic Transmission

## 3. Air Breather Hose S510208

### A: REMOVAL S510208A18

1) Disconnect the air breather hoses.

#### ● 3.0 L and TURBO models

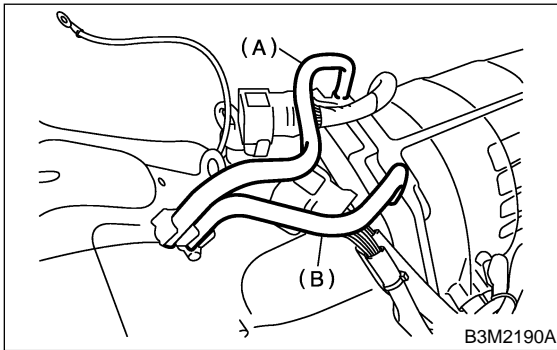

- (A) Air breather hose (Transmission case)
- (B) Air breather hose (Oil pump housing)

#### ● Except 3.0 L and TURBO models

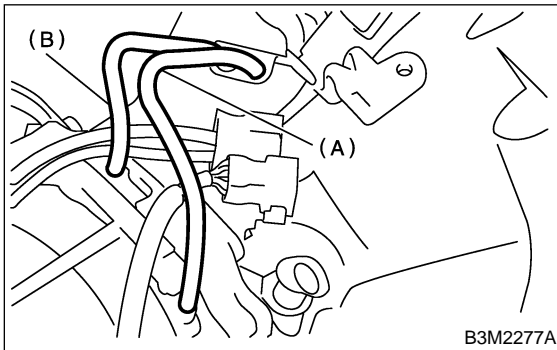

- (A) Air breather hose (Transmission case)
- (B) Air breather hose (Oil pump housing)

### B: INSTALLATION S510208A11

1) Install air breather hoses.

#### ● 3.0 L and TURBO models

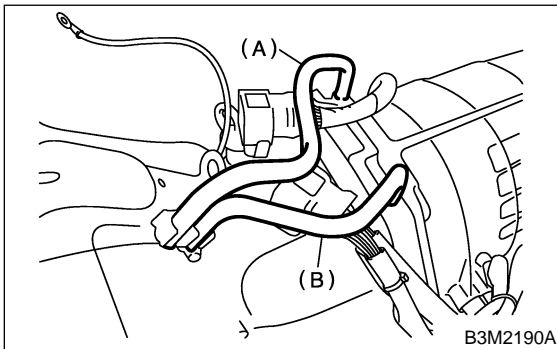

- (A) Air breather hose (Transmission case)
- (B) Air breather hose (Oil pump housing)

#### ● Except 3.0 L and TURBO models

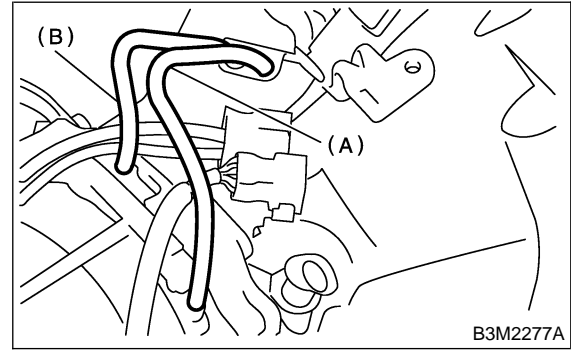

- (A) Air breather hose (Transmission case)
- (B) Air breather hose (Oil pump housing)

### C: INSPECTION S510208A10

Make sure the hose is not cracked or clogged.

# AIR BREATHER HOSE

Automatic Transmission

## 3. Air Breather Hose S510208

### A: REMOVAL S510208A18

1) Disconnect the air breather hoses.

#### ● 3.0 L and TURBO models

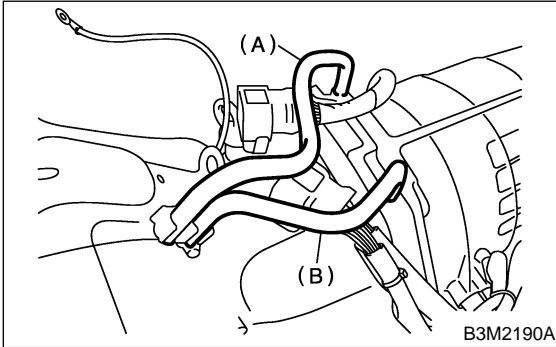

- (A) Air breather hose (Transmission case)
- (B) Air breather hose (Oil pump housing)

#### ● Except 3.0 L and TURBO models

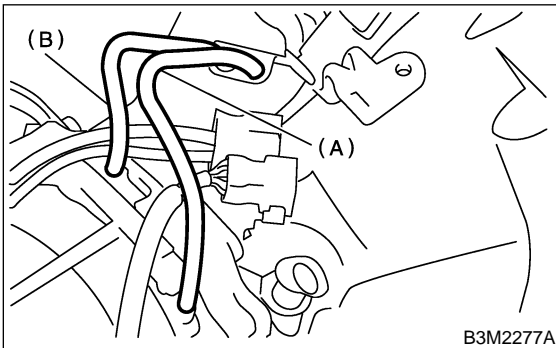

- (A) Air breather hose (Transmission case)
- (B) Air breather hose (Oil pump housing)

### B: INSTALLATION S510208A11

1) Install air breather hoses.

#### ● 3.0 L and TURBO models

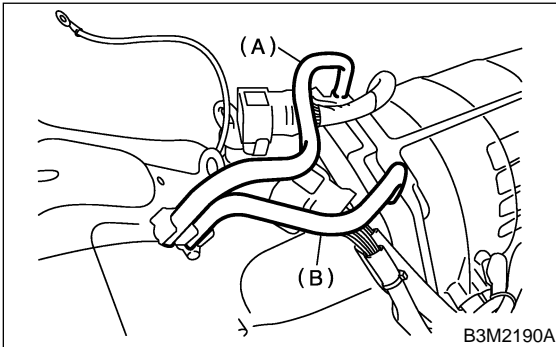

- (A) Air breather hose (Transmission case)
- (B) Air breather hose (Oil pump housing)

#### ● Except 3.0 L and TURBO models

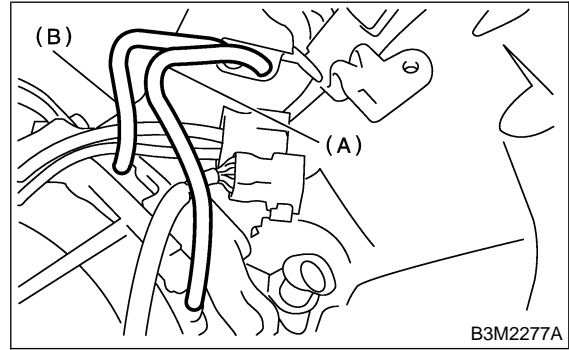

- (A) Air breather hose (Transmission case)
- (B) Air breather hose (Oil pump housing)

### C: INSPECTION S510208A10

Make sure the hose is not cracked or clogged.

## 4. Oil Charger Pipe S510203

### A: REMOVAL S510203A18

1) Remove the oil charger pipe, and remove the O-ring from the flange face. Attach the O-ring to the pipe.

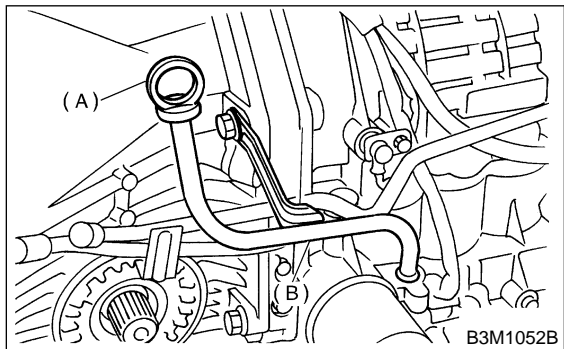

- (A) Oil level gauge
- (B) Oil charger pipe

### B: INSTALLATION S510203A11

1) Install the oil charger pipe with O-ring.

#### NOTE:

Be careful not to damage the O-ring.

#### **Tightening torque:**

**41 N·m (4.2 kgf-m, 30.4 ft-lb)**

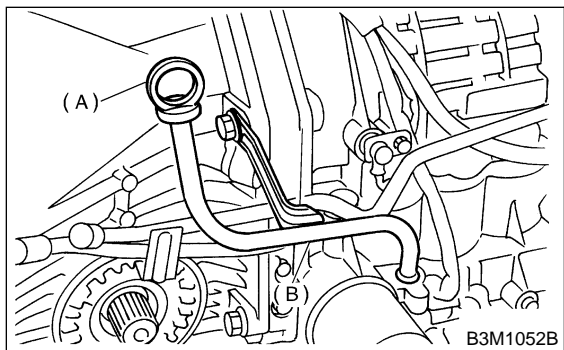

- (A) Oil level gauge
- (B) Oil charger pipe

### C: INSPECTION S510203A10

Make sure the oil charger pipe is not deformed or otherwise damaged.

## 4. Oil Charger Pipe S510203

### A: REMOVAL S510203A18

1) Remove the oil charger pipe, and remove the O-ring from the flange face. Attach the O-ring to the pipe.

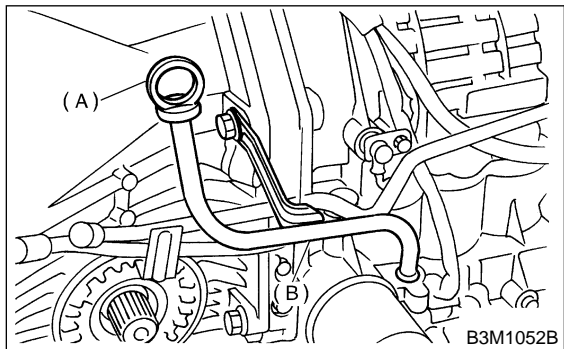

- (A) Oil level gauge
- (B) Oil charger pipe

### B: INSTALLATION S510203A11

1) Install the oil charger pipe with O-ring.

**NOTE:**

Be careful not to damage the O-ring.

**Tightening torque:**

**41 N·m (4.2 kgf-m, 30.4 ft-lb)**

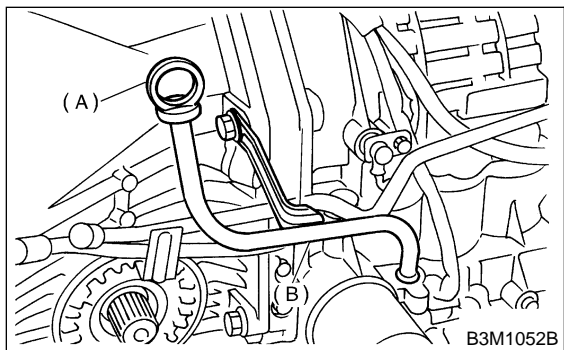

- (A) Oil level gauge
- (B) Oil charger pipe

### C: INSPECTION S510203A10

Make sure the oil charger pipe is not deformed or otherwise damaged.



## 5. Oil Cooler Pipes S510209

### A: REMOVAL S510209A18

- 1) Remove oil charger pipe. <Ref. to AT-29, REMOVAL, Oil Charger Pipe.>
- 2) Remove the oil cooler inlet and outlet pipes.

**NOTE:**

When removing outlet pipes, be careful not to lose balls and springs used with retaining screws.

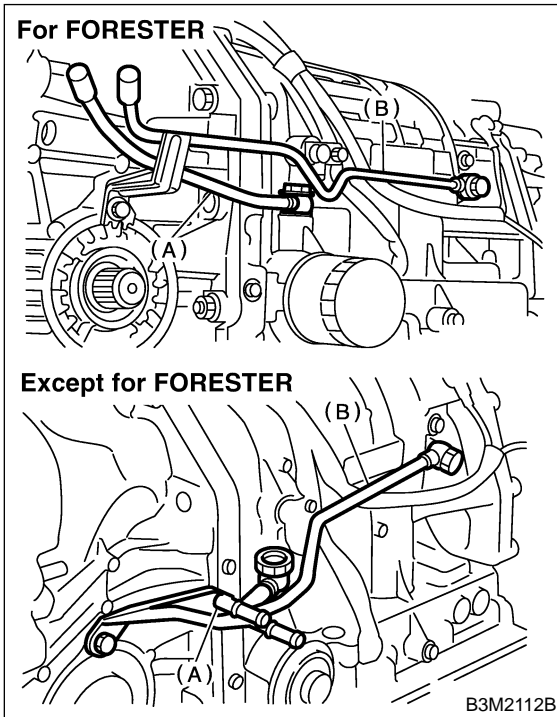

- (A) Outlet pipe
- (B) Inlet pipe

### B: INSTALLATION S510209A11

- 1) Insert oil cooler outlet ball and spring.
- 2) Install the oil cooler outlet pipe with new gaskets.

**Tightening torque:**

**44 N·m (4.5 kgf-m, 32.5 ft-lb)**

- 3) Install the oil cooler inlet pipe with new gaskets.

**Tightening torque:**

**25 N·m (2.5 kgf-m, 18.1 ft-lb)**

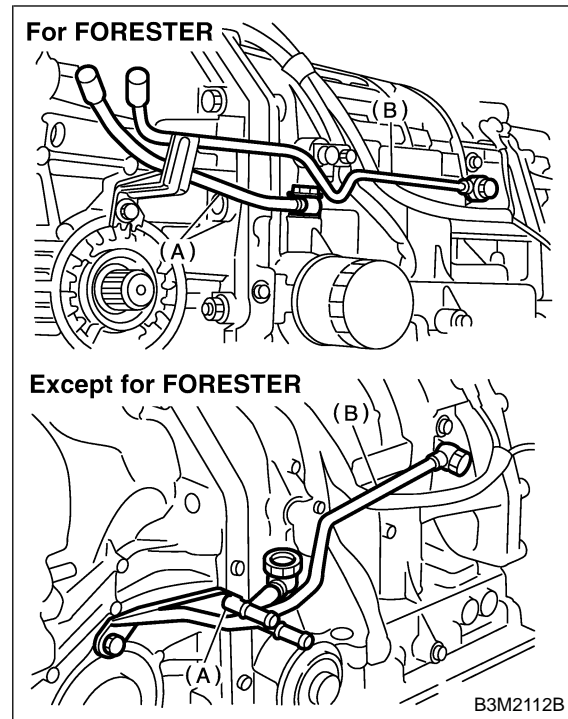

- (A) Outlet pipe
- (B) Inlet pipe

- 4) Install oil charger pipe with O-ring. <Ref. to AT-29, INSTALLATION, Oil Charger Pipe.>

### C: INSPECTION S510209A10

Make sure the oil cooler pipe is not deformed or otherwise damaged.

## 5. Oil Cooler Pipes S510209

### A: REMOVAL S510209A18

- 1) Remove oil charger pipe. <Ref. to AT-29, REMOVAL, Oil Charger Pipe.>
- 2) Remove the oil cooler inlet and outlet pipes.

**NOTE:**

When removing outlet pipes, be careful not to lose balls and springs used with retaining screws.

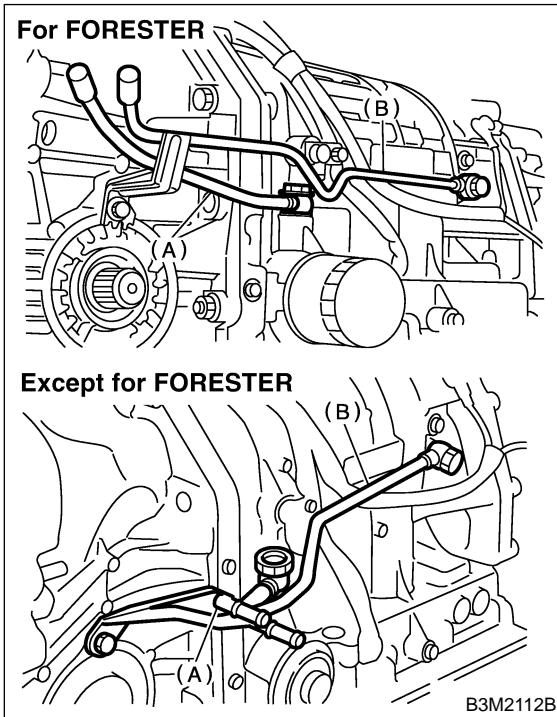

- (A) Outlet pipe
- (B) Inlet pipe

### B: INSTALLATION S510209A11

- 1) Insert oil cooler outlet ball and spring.
- 2) Install the oil cooler outlet pipe with new gaskets.

**Tightening torque:**

**44 N·m (4.5 kgf-m, 32.5 ft-lb)**

- 3) Install the oil cooler inlet pipe with new gaskets.

**Tightening torque:**

**25 N·m (2.5 kgf-m, 18.1 ft-lb)**

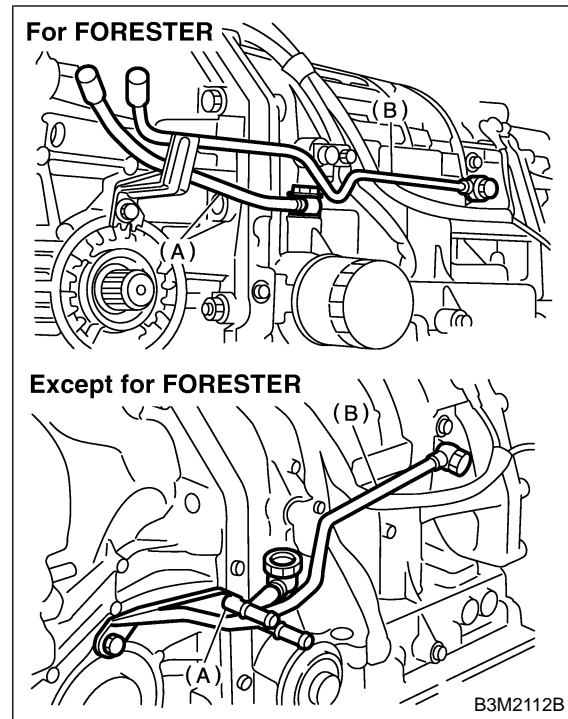

- (A) Outlet pipe
- (B) Inlet pipe

- 4) Install oil charger pipe with O-ring. <Ref. to AT-29, INSTALLATION, Oil Charger Pipe.>

### C: INSPECTION S510209A10

Make sure the oil cooler pipe is not deformed or otherwise damaged.

## 6. Vehicle Speed Sensors and Torque Converter Turbine Speed Sensor

S510586

### A: REMOVAL

S510586A18

- 1) Extract the torque converter clutch assembly. <Ref. to AT-35, REMOVAL, Torque Converter Clutch Assembly.>
- 2) Disconnect the air breather hoses. <Ref. to AT-28, REMOVAL, Air Breather Hose.>
- 3) Disconnect transmission harness connector from stay.

#### NOTE:

Lift-up lever behind connector and disconnect it from stay.

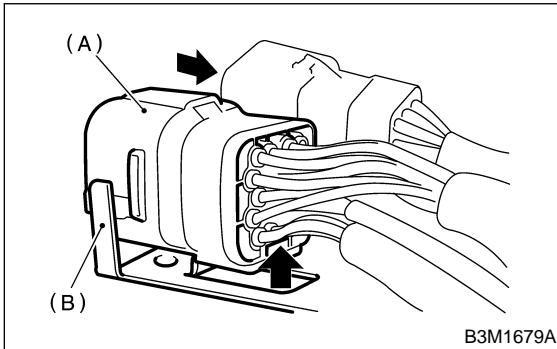

B3M1679A

- (A) Transmission harness
- (B) Stay

- 4) Disconnect inhibitor switch connector from stay.
- 5) Wrap vinyl tape around the nipple attached to the air breather hose.
- 6) Remove pitching stopper bracket.
- 7) Remove the oil charger pipe. <Ref. to AT-29, REMOVAL, Oil Charger Pipe.>
- 8) Remove the oil cooler pipes. <Ref. to AT-30, REMOVAL, Oil Cooler Pipes.>
- 9) Insert a shop cloth into the installation holes of oil charger pipe and oil cooler pipe.

- 10) Remove rear vehicle speed sensor.

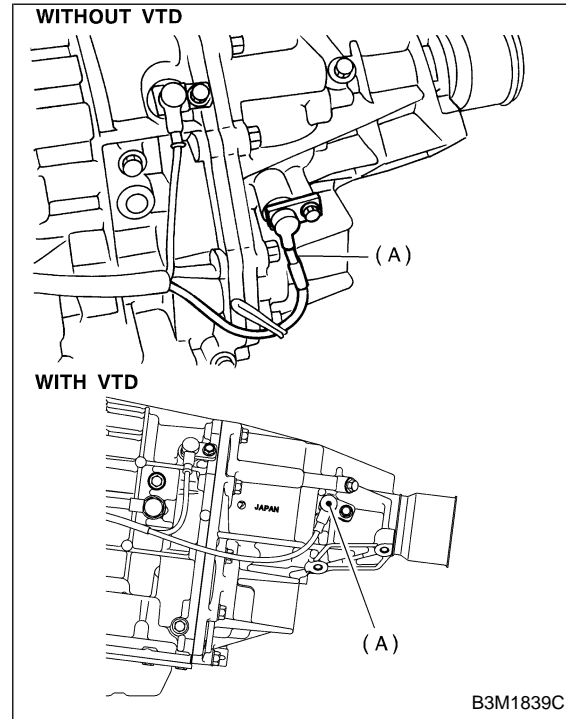

B3M1839C

- (A) Rear vehicle speed sensor

- 11) Remove front vehicle speed sensor and torque converter turbine speed sensor.

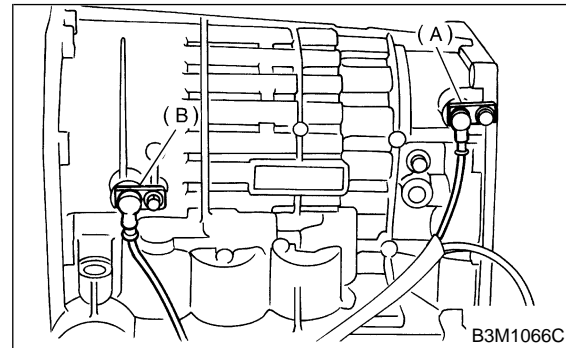

B3M1066C

- (A) Front vehicle speed sensor
- (B) Torque converter turbine speed sensor

- 12) Remove the inhibitor switch.

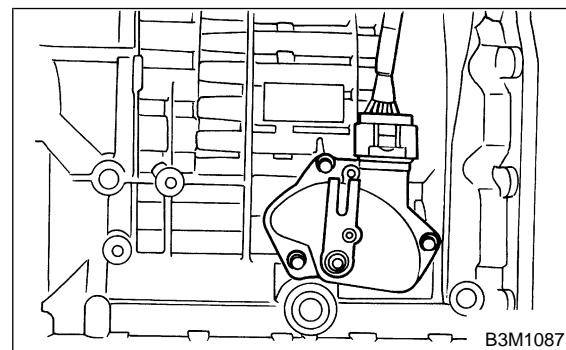

B3M1087

# VEHICLE SPEED SENSORS AND TORQUE CONVERTER TURBINE SPEED SENSOR

Automatic Transmission

13) Prepare a block of wood. Turn over the transmission case and make it secure with the block of wood.

**NOTE:**

Turn over in the direction the inhibitor switch was installed.

14) Remove the oil pan.

**NOTE:**

Use a scraper to remove oil pan.

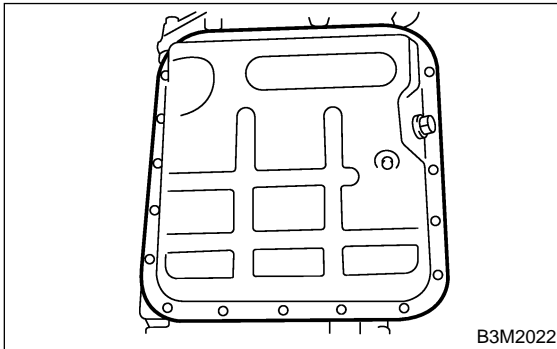

15) Disconnect the harness connectors for the solenoids, duty solenoids, ATF temperature sensor and the ground cord.

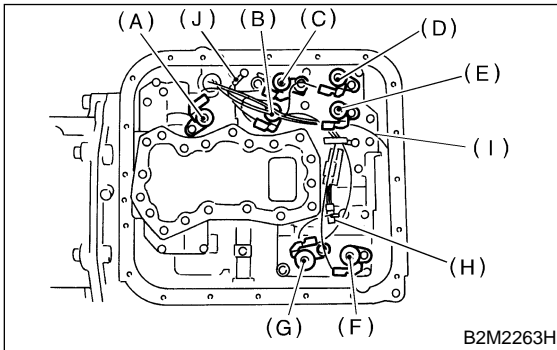

- (A) Lock-up duty solenoid (Blue)
- (B) Low clutch timing solenoid (Gray)
- (C) Line pressure duty solenoid (Red)
- (D) Shift solenoid 2 (Yellow)
- (E) Shift solenoid 1 (Green)
- (F) 2-4 brake timing solenoid (Black)
- (G) 2-4 brake duty solenoid (Red)
- (H) ATF temperature sensor
- (I) Transfer duty solenoid (Brown)
- (J) Transmission ground

16) Remove transmission harness.

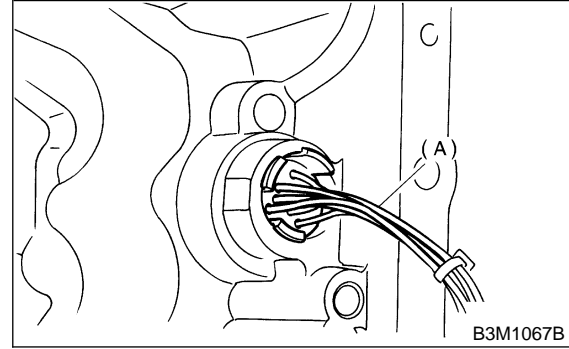

(A) Transmission harness

## B: INSTALLATION

S510586A11

1) Install and route the transmission harness.

**NOTE:**

Be careful not to damage the harness.

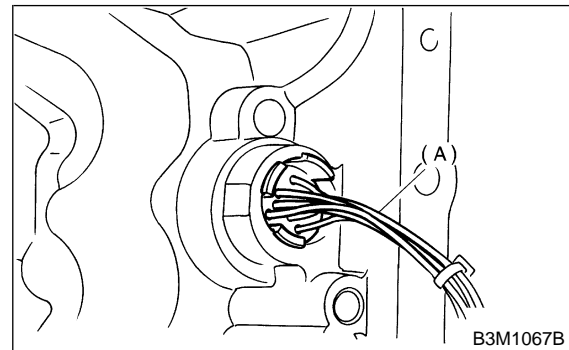

(A) Transmission harness

2) Connect all connectors.

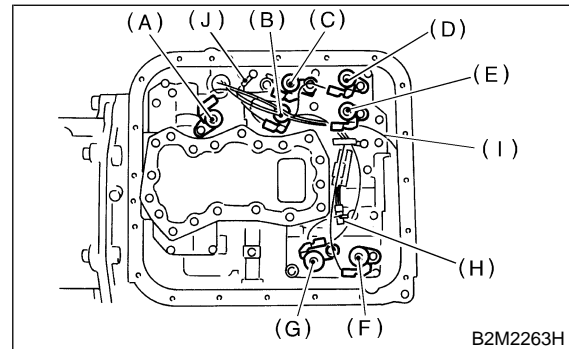

- (A) Lock-up duty solenoid (Blue)
- (B) Low clutch timing solenoid (Gray)
- (C) Line pressure duty solenoid (Red)
- (D) Shift solenoid 2 (Yellow)
- (E) Shift solenoid 1 (Green)
- (F) 2-4 brake timing solenoid (Black)
- (G) 2-4 brake duty solenoid (Red)
- (H) ATF temperature sensor
- (I) Transfer duty solenoid (Brown)
- (J) Transmission ground

3) Apply proper amount of liquid gasket to the entire oil pan mating surface.

**Liquid gasket**

**THREE BOND 1217B**

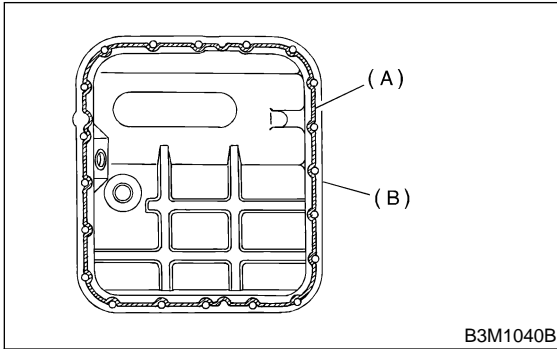

- (A) THREE BOND (Part No. 1217B)
- (B) Oil pan

4) Besides bolt hole on transmission side, completely fill in liquid gasket at three holes.

**Fluid packing:**

**THREE BOND 1217B**

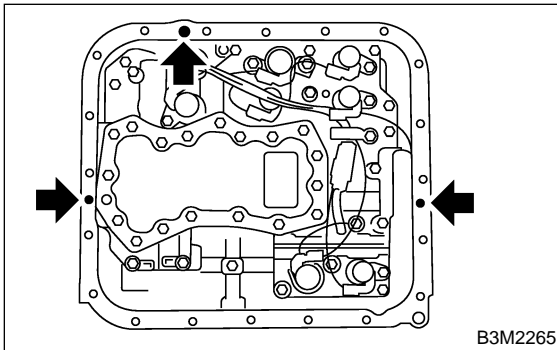

5) Install the oil pan to the transmission case assembly.

**NOTE:**

Tighten the bolts evenly.

**Tightening torque:**

**5 N·m (0.5 kgf-m, 3.6 ft-lb)**

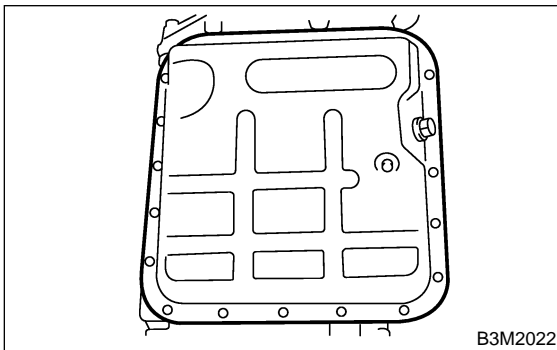

6) Turn over the transmission case to its original position.

7) Install torque converter turbine speed sensor and front vehicle speed sensor.

**Tightening torque:**

**7 N·m (0.7 kgf-m, 5.1 ft-lb)**

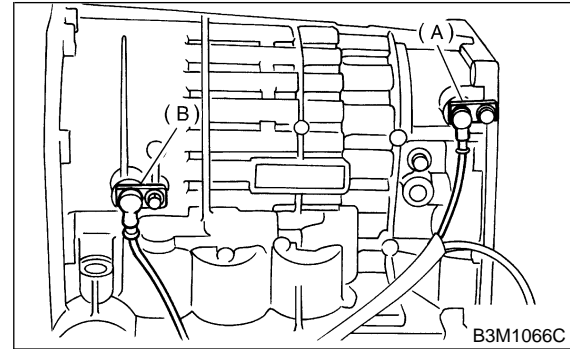

- (A) Front vehicle speed sensor
- (B) Torque converter turbine speed sensor

8) Install the rear vehicle speed sensor.

**Tightening torque:**

**7 N·m (0.7 kgf-m, 5.1 ft-lb)**

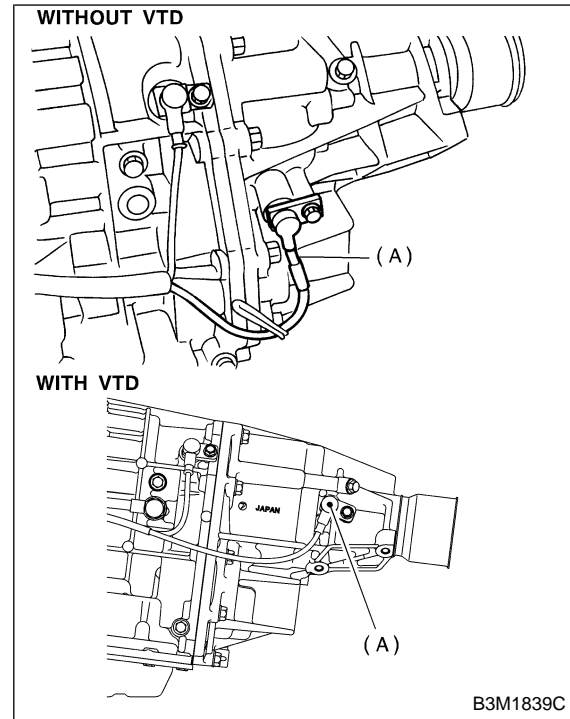

- (A) Rear vehicle speed sensor

9) Remove the vinyl tape, and then install air breather hose. <Ref. to AT-28, INSTALLATION, Air Breather Hose.>

10) Install the oil cooler pipes. <Ref. to AT-30, INSTALLATION, Oil Cooler Pipes.>

11) Install the oil charger pipe. <Ref. to AT-29, INSTALLATION, Oil Charger Pipes.>

12) Install the torque converter clutch assembly. <Ref. to AT-35, INSTALLATION, Torque Converter Clutch Assembly.>

# VEHICLE SPEED SENSORS AND TORQUE CONVERTER TURBINE SPEED SENSOR

Automatic Transmission

---

- 13) Install inhibitor switch and adjust the inhibitor switch by referring to Supplement AT section.
- 14) Install inhibitor switch connector and transmission connector to the stay.
- 15) Install pitching stopper bracket.

***Tightening torque:***

***41 N·m (4.2 kgf-m, 30.4 ft-lb)***

## 6. Vehicle Speed Sensors and Torque Converter Turbine Speed Sensor

S510586

### A: REMOVAL

S510586A18

- 1) Extract the torque converter clutch assembly. <Ref. to AT-35, REMOVAL, Torque Converter Clutch Assembly.>
- 2) Disconnect the air breather hoses. <Ref. to AT-28, REMOVAL, Air Breather Hose.>
- 3) Disconnect transmission harness connector from stay.

#### NOTE:

Lift-up lever behind connector and disconnect it from stay.

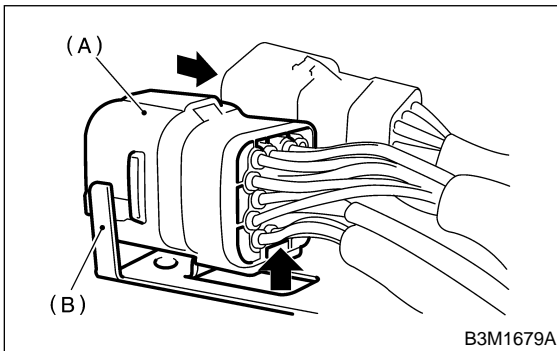

B3M1679A

- (A) Transmission harness
- (B) Stay

- 4) Disconnect inhibitor switch connector from stay.
- 5) Wrap vinyl tape around the nipple attached to the air breather hose.
- 6) Remove pitching stopper bracket.
- 7) Remove the oil charger pipe. <Ref. to AT-29, REMOVAL, Oil Charger Pipe.>
- 8) Remove the oil cooler pipes. <Ref. to AT-30, REMOVAL, Oil Cooler Pipes.>
- 9) Insert a shop cloth into the installation holes of oil charger pipe and oil cooler pipe.

- 10) Remove rear vehicle speed sensor.

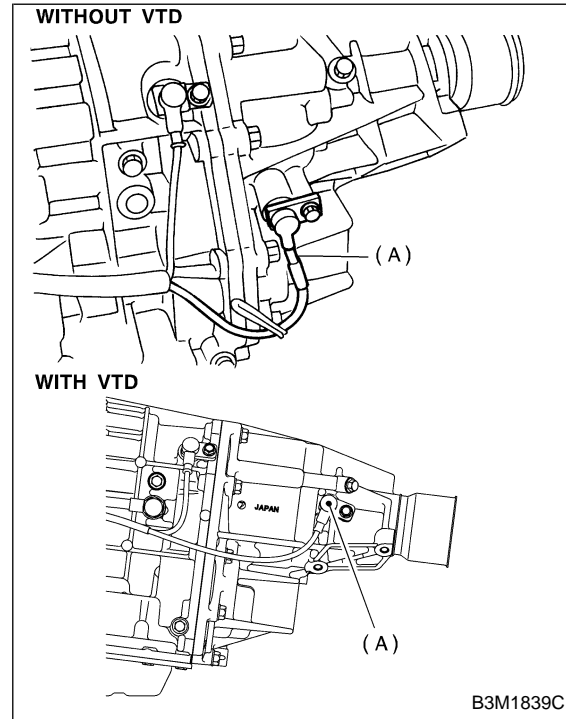

B3M1839C

- (A) Rear vehicle speed sensor

- 11) Remove front vehicle speed sensor and torque converter turbine speed sensor.

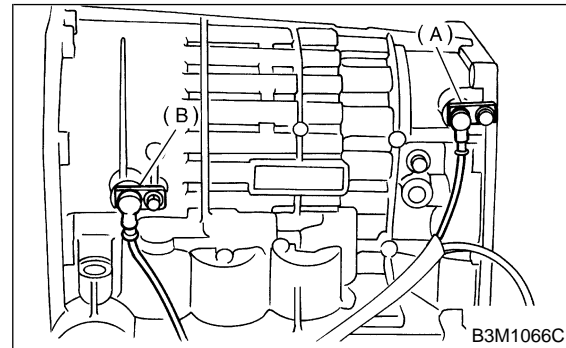

B3M1066C

- (A) Front vehicle speed sensor
- (B) Torque converter turbine speed sensor

- 12) Remove the inhibitor switch.

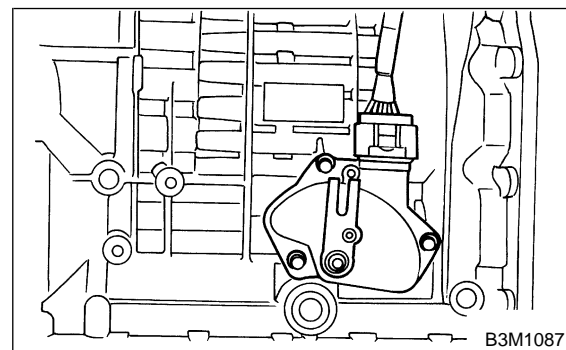

B3M1087

# VEHICLE SPEED SENSORS AND TORQUE CONVERTER TURBINE SPEED SENSOR

Automatic Transmission

13) Prepare a block of wood. Turn over the transmission case and make it secure with the block of wood.

**NOTE:**

Turn over in the direction the inhibitor switch was installed.

14) Remove the oil pan.

**NOTE:**

Use a scraper to remove oil pan.

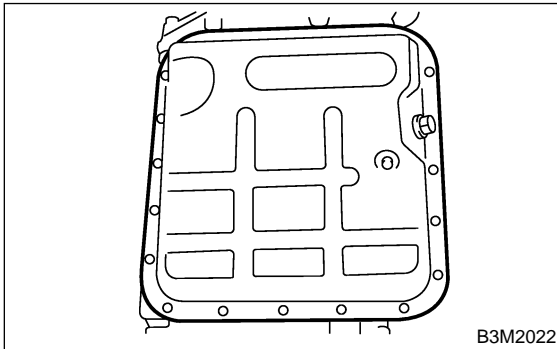

15) Disconnect the harness connectors for the solenoids, duty solenoids, ATF temperature sensor and the ground cord.

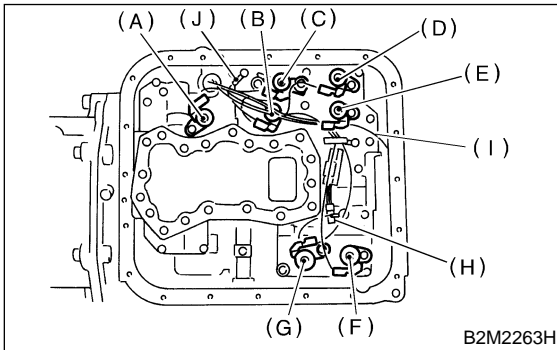

- (A) Lock-up duty solenoid (Blue)
- (B) Low clutch timing solenoid (Gray)
- (C) Line pressure duty solenoid (Red)
- (D) Shift solenoid 2 (Yellow)
- (E) Shift solenoid 1 (Green)
- (F) 2-4 brake timing solenoid (Black)
- (G) 2-4 brake duty solenoid (Red)
- (H) ATF temperature sensor
- (I) Transfer duty solenoid (Brown)
- (J) Transmission ground

16) Remove transmission harness.

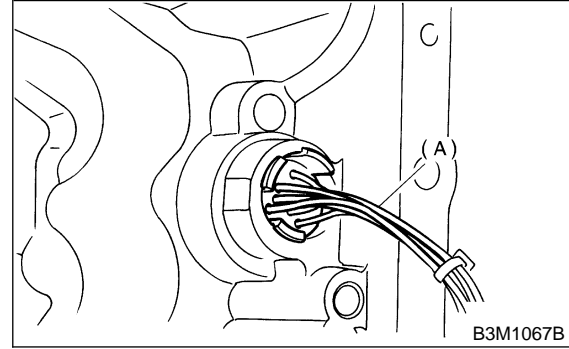

(A) Transmission harness

## B: INSTALLATION

S510586A11

1) Install and route the transmission harness.

**NOTE:**

Be careful not to damage the harness.

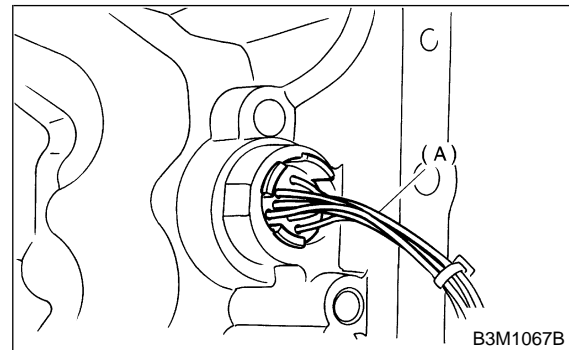

(A) Transmission harness

2) Connect all connectors.

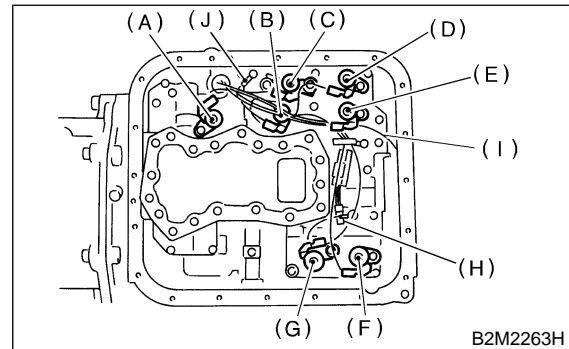

- (A) Lock-up duty solenoid (Blue)
- (B) Low clutch timing solenoid (Gray)
- (C) Line pressure duty solenoid (Red)
- (D) Shift solenoid 2 (Yellow)
- (E) Shift solenoid 1 (Green)
- (F) 2-4 brake timing solenoid (Black)
- (G) 2-4 brake duty solenoid (Red)
- (H) ATF temperature sensor
- (I) Transfer duty solenoid (Brown)
- (J) Transmission ground



3) Apply proper amount of liquid gasket to the entire oil pan mating surface.

**Liquid gasket**

**THREE BOND 1217B**

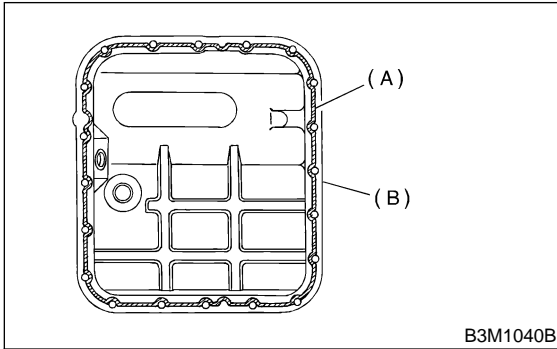

- (A) THREE BOND (Part No. 1217B)
- (B) Oil pan

4) Besides bolt hole on transmission side, completely fill in liquid gasket at three holes.

**Fluid packing:**

**THREE BOND 1217B**

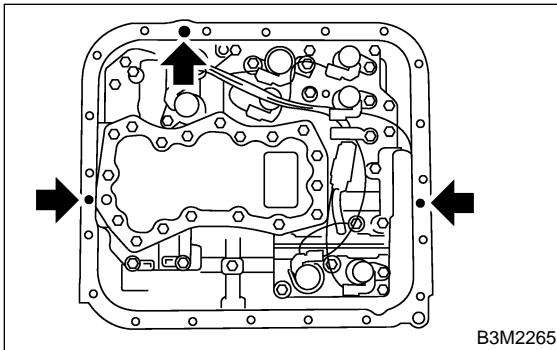

5) Install the oil pan to the transmission case assembly.

**NOTE:**

Tighten the bolts evenly.

**Tightening torque:**

**5 N·m (0.5 kgf-m, 3.6 ft-lb)**

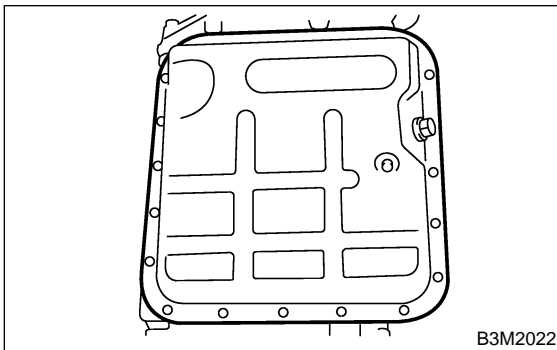

6) Turn over the transmission case to its original position.

7) Install torque converter turbine speed sensor and front vehicle speed sensor.

**Tightening torque:**

**7 N·m (0.7 kgf-m, 5.1 ft-lb)**

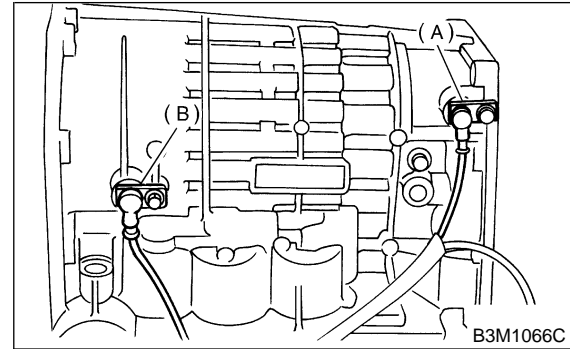

- (A) Front vehicle speed sensor
- (B) Torque converter turbine speed sensor

8) Install the rear vehicle speed sensor.

**Tightening torque:**

**7 N·m (0.7 kgf-m, 5.1 ft-lb)**

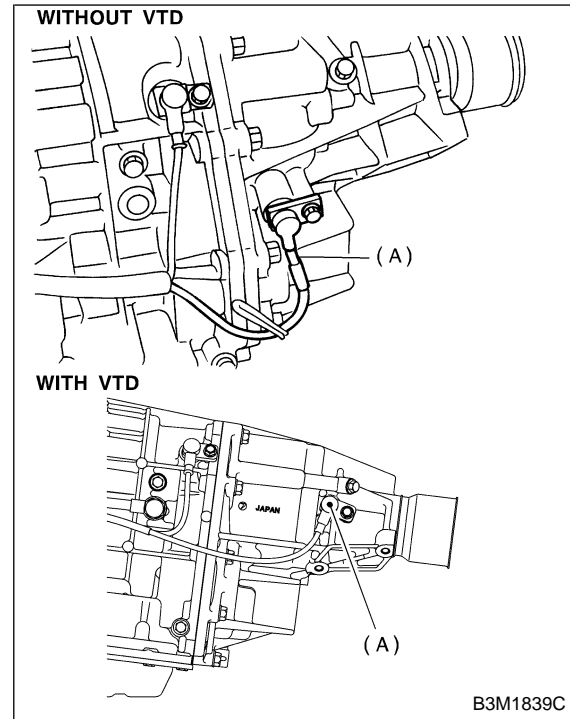

- (A) Rear vehicle speed sensor

9) Remove the vinyl tape, and then install air breather hose. <Ref. to AT-28, INSTALLATION, Air Breather Hose.>

10) Install the oil cooler pipes. <Ref. to AT-30, INSTALLATION, Oil Cooler Pipes.>

11) Install the oil charger pipe. <Ref. to AT-29, INSTALLATION, Oil Charger Pipes.>

12) Install the torque converter clutch assembly. <Ref. to AT-35, INSTALLATION, Torque Converter Clutch Assembly.>

# VEHICLE SPEED SENSORS AND TORQUE CONVERTER TURBINE SPEED SENSOR

Automatic Transmission

---

- 13) Install inhibitor switch and adjust the inhibitor switch by referring to Supplement AT section.
- 14) Install inhibitor switch connector and transmission connector to the stay.
- 15) Install pitching stopper bracket.

***Tightening torque:***

***41 N·m (4.2 kgf-m, 30.4 ft-lb)***

## 7. Torque Converter Clutch Assembly S510210

### A: REMOVAL S510210A18

1) Extract the torque converter clutch assembly.

**NOTE:**

- Extract the torque converter clutch horizontally. Be careful not to scratch the bushing inside the oil pump shaft.
- Note that oil pump shaft also comes out.

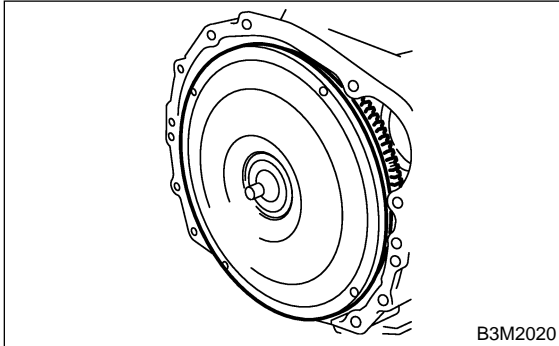

2) Remove the input shaft.

**NOTE:**

When the torque converter clutch assembly is removed, the input shaft will come out.

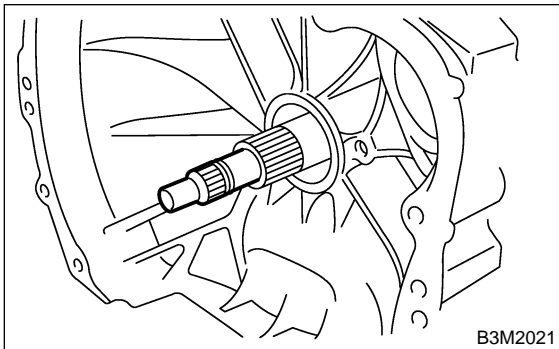

3) Extract the oil pump shaft from torque converter clutch.

4) Remove the clip from torque converter clutch.

### B: INSTALLATION S510210A11

- 1) Install the clip to torque converter clutch.
- 2) Install the oil pump shaft to the torque converter clutch.

**NOTE:**

Make sure the clip fits securely in its groove.

3) Insert the input shaft while turning lightly by hand.

**NOTE:**

Be careful not to damage the bushing.

**Normal protrusion A:**

**50 — 55 mm (1.97 — 2.17 in)**

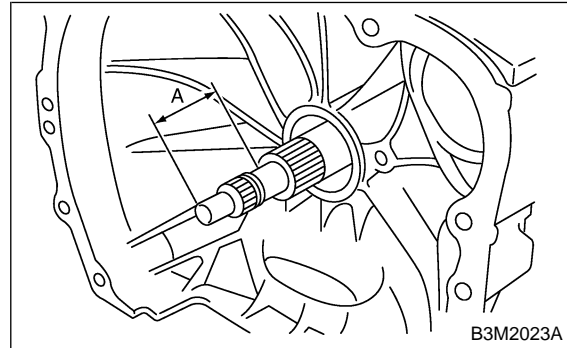

4) Holding the torque converter clutch assembly by hand, carefully install it to the torque converter clutch case. Be careful not to damage the bushing. Also avoid undue contact between the oil pump shaft bushing and stator shaft portion of the oil pump cover.

5) Rotate the shaft lightly by hand to engage the splines securely.

**Dimension A:**

**1.6 L and 2.0 L models; -1.3 to -1.1 mm (-0.051 to -0.043 in)**

**2.0 L TURBO, 2.5 L and 3.0 L models; 2.7 — 2.9 mm (0.106 — 0.114 in)**

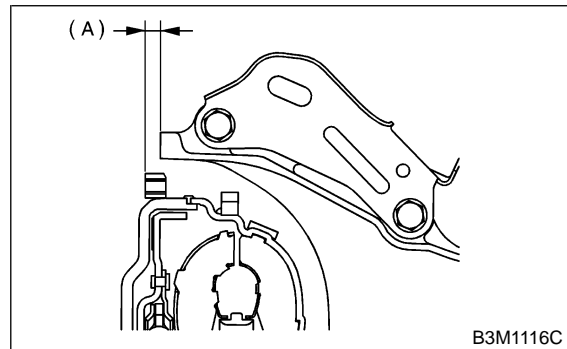

(A) Dimension A

### C: INSPECTION S510210A10

Make sure the ring gear is not damaged and that the protrusion on the edge of the torque converter clutch is not deformed or otherwise damaged.

## 7. Torque Converter Clutch Assembly S510210

### A: REMOVAL S510210A18

1) Extract the torque converter clutch assembly.

**NOTE:**

- Extract the torque converter clutch horizontally. Be careful not to scratch the bushing inside the oil pump shaft.
- Note that oil pump shaft also comes out.

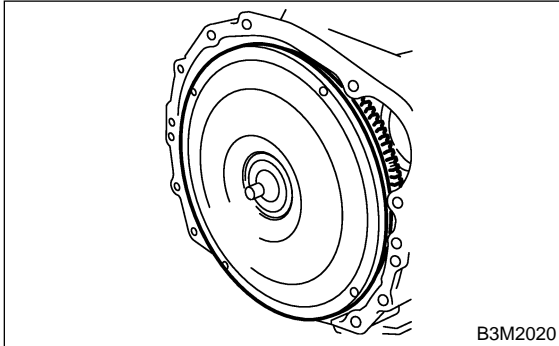

2) Remove the input shaft.

**NOTE:**

When the torque converter clutch assembly is removed, the input shaft will come out.

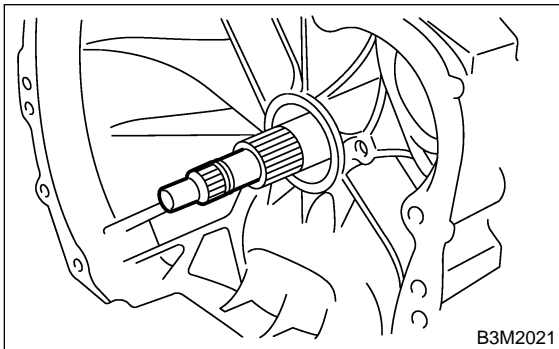

3) Extract the oil pump shaft from torque converter clutch.

4) Remove the clip from torque converter clutch.

### B: INSTALLATION S510210A11

- 1) Install the clip to torque converter clutch.
- 2) Install the oil pump shaft to the torque converter clutch.

**NOTE:**

Make sure the clip fits securely in its groove.

3) Insert the input shaft while turning lightly by hand.

**NOTE:**

Be careful not to damage the bushing.

**Normal protrusion A:**

**50 — 55 mm (1.97 — 2.17 in)**

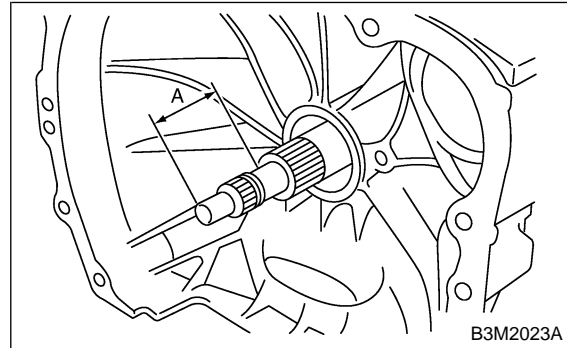

4) Holding the torque converter clutch assembly by hand, carefully install it to the torque converter clutch case. Be careful not to damage the bushing. Also avoid undue contact between the oil pump shaft bushing and stator shaft portion of the oil pump cover.

5) Rotate the shaft lightly by hand to engage the splines securely.

**Dimension A:**

**1.6 L and 2.0 L models; -1.3 to -1.1 mm (-0.051 to -0.043 in)**

**2.0 L TURBO, 2.5 L and 3.0 L models; 2.7 — 2.9 mm (0.106 — 0.114 in)**

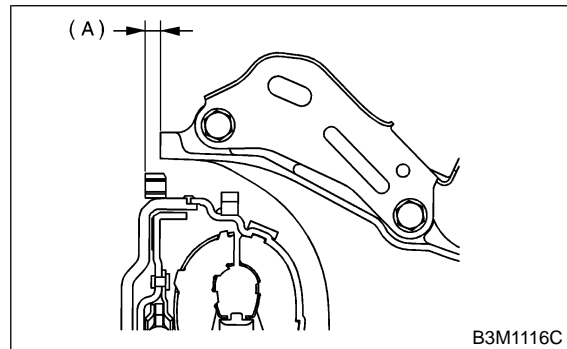

(A) Dimension A

### C: INSPECTION S510210A10

Make sure the ring gear is not damaged and that the protrusion on the edge of the torque converter clutch is not deformed or otherwise damaged.

# EXTENSION CASE

Automatic Transmission

## 8. Extension Case S510587

### A: REMOVAL S510587A18

1) Remove rear vehicle speed sensor.

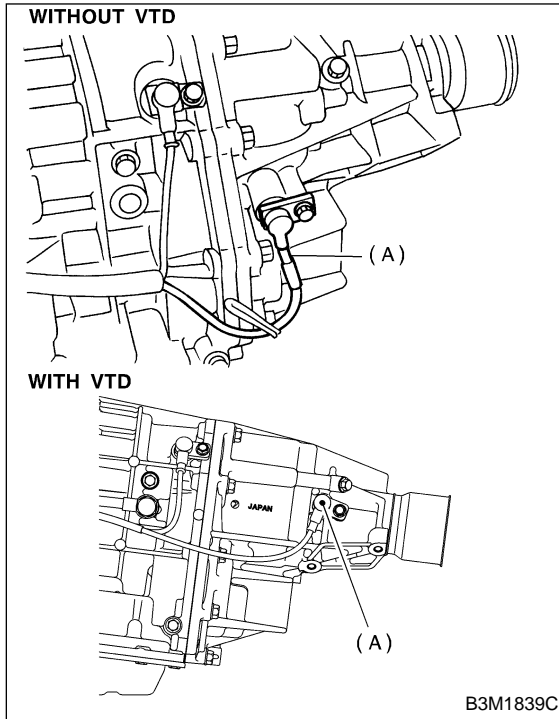

(A) Rear vehicle speed sensor

2) Separate transmission case and extension case sections.

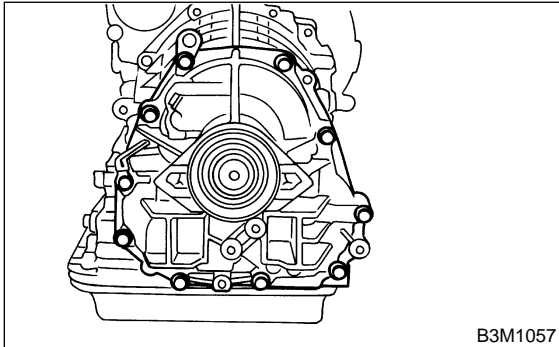

### B: INSTALLATION S510587A11

1) Attach the selected thrust needle bearing to the end surface of reduction drive gear with vaseline.

NOTE:

Install thrust needle bearing in the correct direction.

2) Install new gasket.

3) Install the extension case to the transmission case.

4) Tighten bolts to secure the case.

**Tightening torque:**

**25 N·m (2.5 kgf-m, 18.1 ft-lb)**

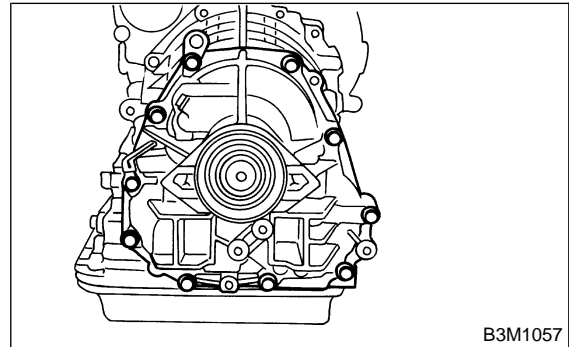

5) Install the rear vehicle speed sensor.

**Tightening torque:**

**7 N·m (0.7 kgf-m, 5.1 ft-lb)**

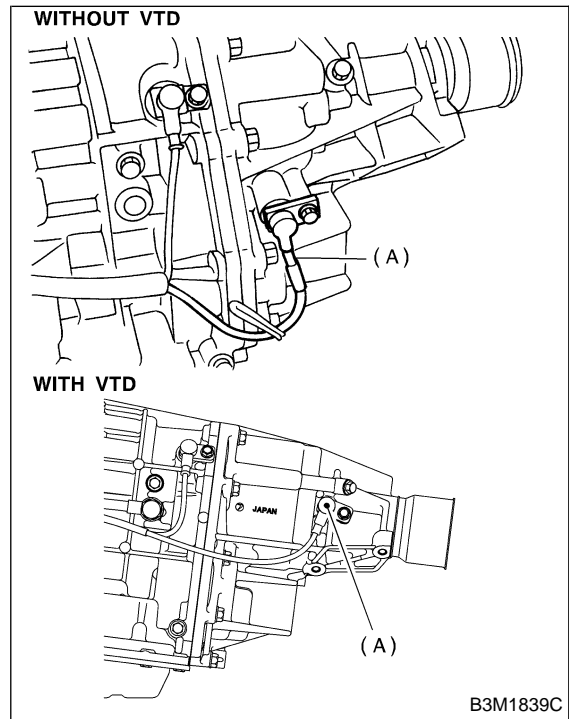

(A) Rear vehicle speed sensor

## C: DISASSEMBLY S510587A06

### 1. WITHOUT VTD S510587A0601

1) Take out the transfer clutch by lightly tapping the end of the rear drive shaft.

**NOTE:**

Be careful not to damage the oil seal in the extension.

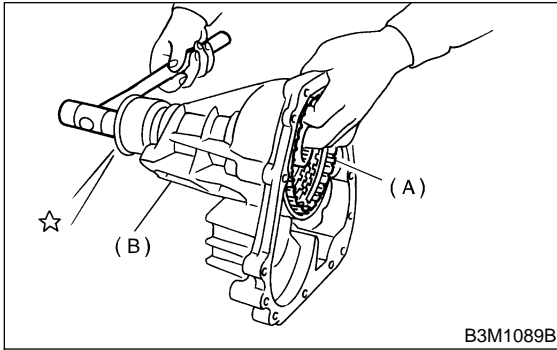

- (A) Extension case
- (B) Transfer clutch

2) Remove the transfer clutch pipe.

**CAUTION:**

Be careful not to bend the pipe.

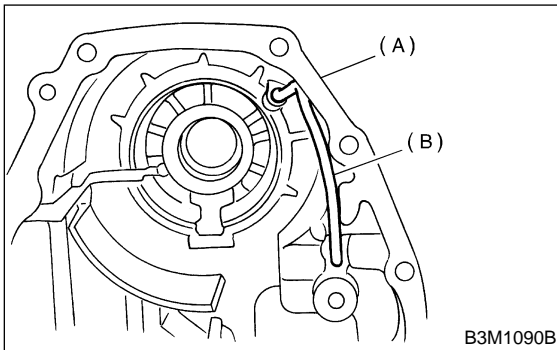

- (A) Extension case
- (B) Transfer clutch pipe

3) Remove the dust cover from the extension case.

4) Remove the oil seal from the extension case.

### 2. WITH VTD S510587A0602

1) Using ST1, ST2, ST3 and a press, remove snap ring.

ST1 398673600 COMPRESSOR

ST2 498627100 SEAT

ST3 398663600 PLIERS

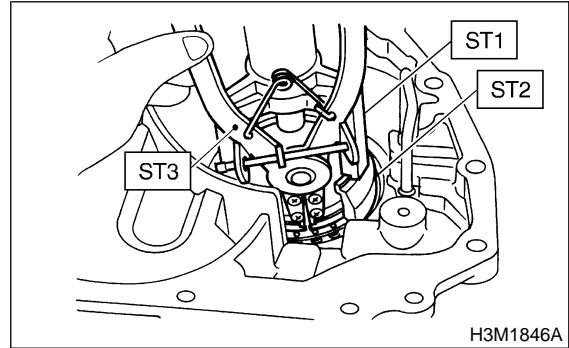

2) Remove test plug.

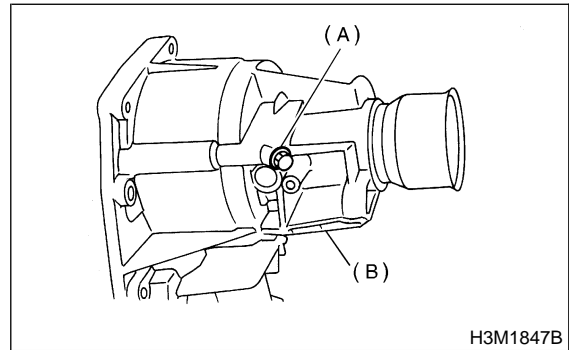

- (A) Extension case
- (B) Test plug

3) Remove clutch piston by compressed air.

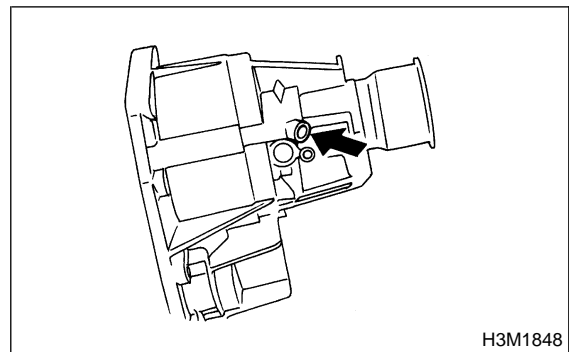

# EXTENSION CASE

Automatic Transmission

4) Remove transfer clutch pipe.

NOTE:

Be careful not to bend the pipe.

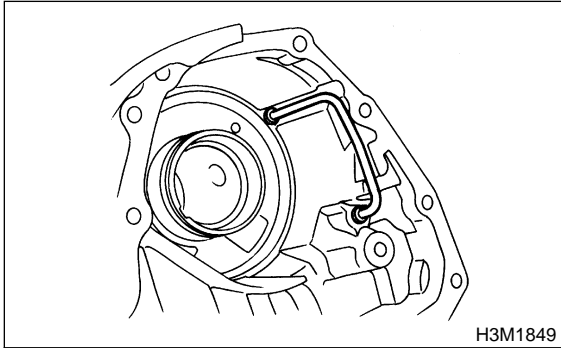

5) Remove the dust cover from the extension case.

6) Remove the oil seal from the extension case.

## D: ASSEMBLY S510587A02

### 1. WITHOUT VTD S510587A0201

1) Using the ST and a press, press in a new oil seal.

ST 498057300 INSTALLER

2) Press in the dust cover.

3) Install the transfer pipe to extension case.

NOTE:

Be careful not to bend the pipe.

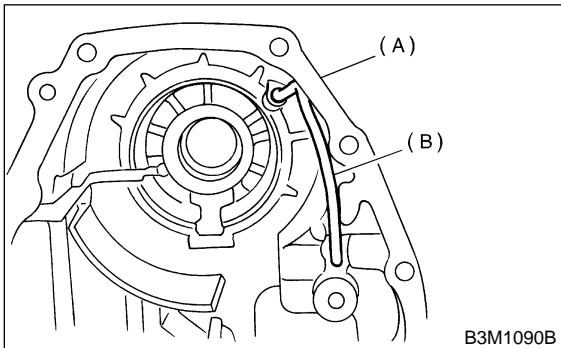

(A) Extension case

(B) Transfer pipe

4) Install the transfer clutch assembly to the case.

NOTE:

- Be careful not to damage the seal rings.
- Insert the clutch assembly fully into position until the bearing shoulder bottoms.

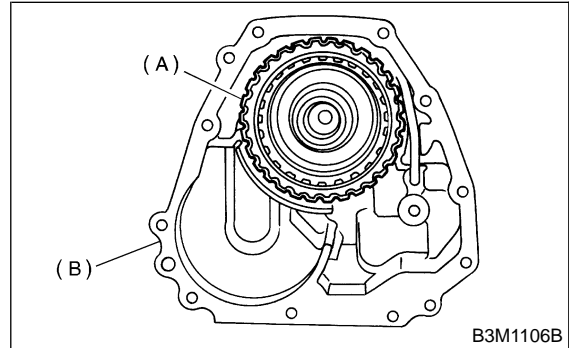

(A) Transfer clutch

(B) Extension case

### 2. WITH VTD S510587A0202

1) Using the ST and a press, press in a new oil seal.

ST 498057300 INSTALLER

2) Press in the dust cover.

3) Install transfer clutch pipe.

NOTE:

Be careful not to bend the pipe.

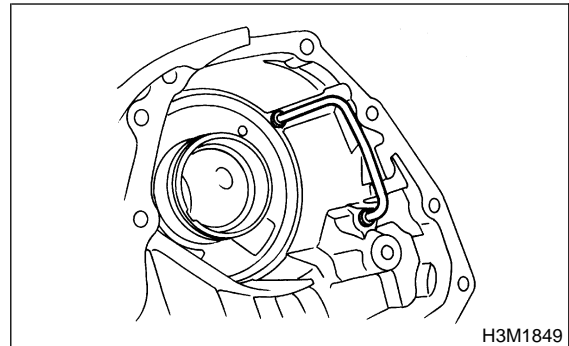

4) Install test plug.

**Tightening torque:**

**13 N·m (1.3 kgf·m, 9.4 ft·lb)**

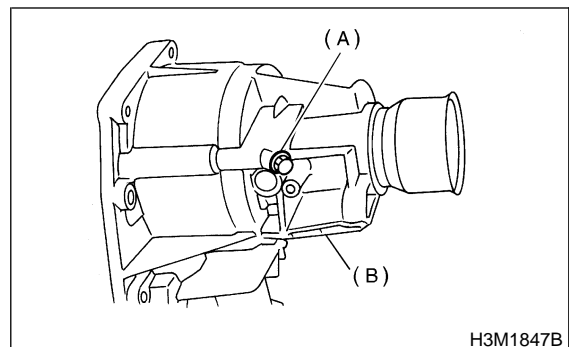

(A) Test plug

(B) Extension case

5) Insert the multi-plate clutch, the drive plate, the driven plate, and the spring retainer.

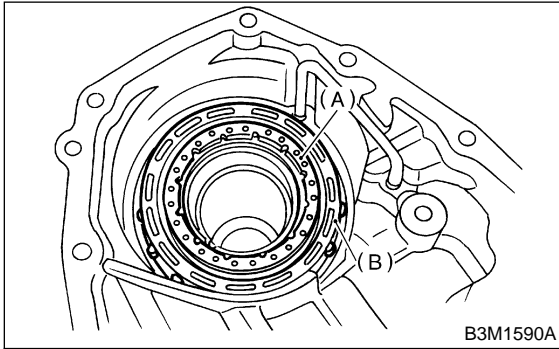

- (A) Spring retainer
- (B) Multi-plate clutch (LSD) piston ASSY

6) Using the ST1, ST2, and ST3, install the snap ring.

- ST1 398673600 COMPRESSOR
- ST2 498627100 SEAT
- ST3 398663600 PLIERS

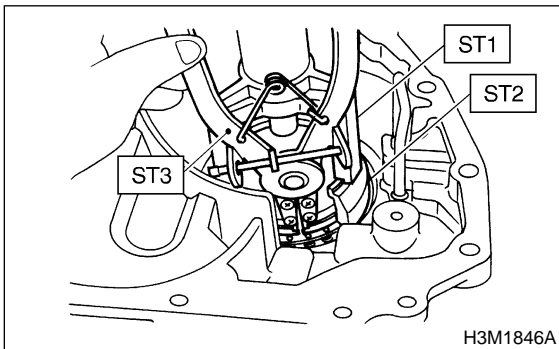

## E: INSPECTION S510587A10

- Use forced air to make sure the transfer pipe and extension case routes are not clogged and do not leak.

- Measure the extension end play and adjust it to within specifications.

Without VTD <Ref. to AT-44, WITHOUT VTD, ADJUSTMENT, Transfer Clutch.>

With VTD <Ref. to AT-44, WITH VTD, ADJUSTMENT, Transfer Clutch.>



# EXTENSION CASE

Automatic Transmission

## 8. Extension Case S510587

### A: REMOVAL S510587A18

1) Remove rear vehicle speed sensor.

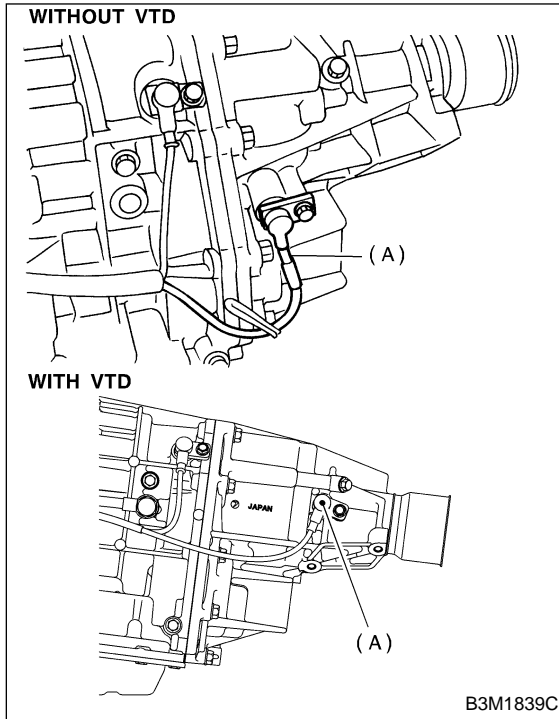

(A) Rear vehicle speed sensor

2) Separate transmission case and extension case sections.

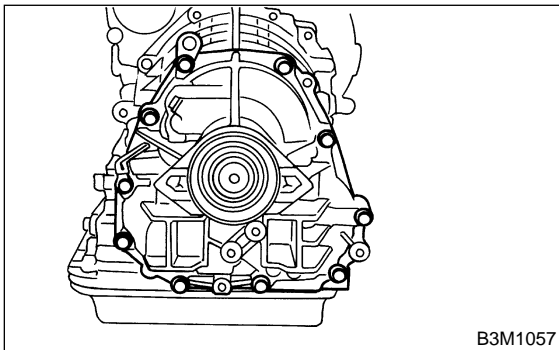

### B: INSTALLATION S510587A11

1) Attach the selected thrust needle bearing to the end surface of reduction drive gear with vaseline.

NOTE:

Install thrust needle bearing in the correct direction.

2) Install new gasket.

3) Install the extension case to the transmission case.

4) Tighten bolts to secure the case.

**Tightening torque:**

**25 N·m (2.5 kgf-m, 18.1 ft-lb)**

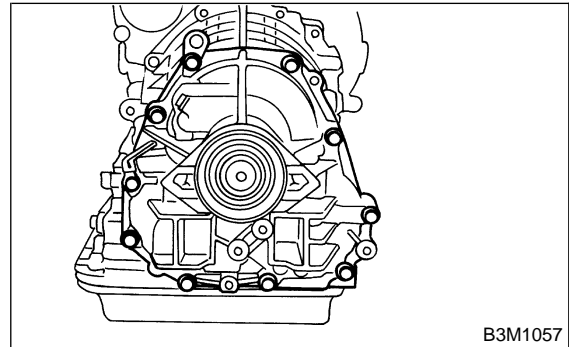

5) Install the rear vehicle speed sensor.

**Tightening torque:**

**7 N·m (0.7 kgf-m, 5.1 ft-lb)**

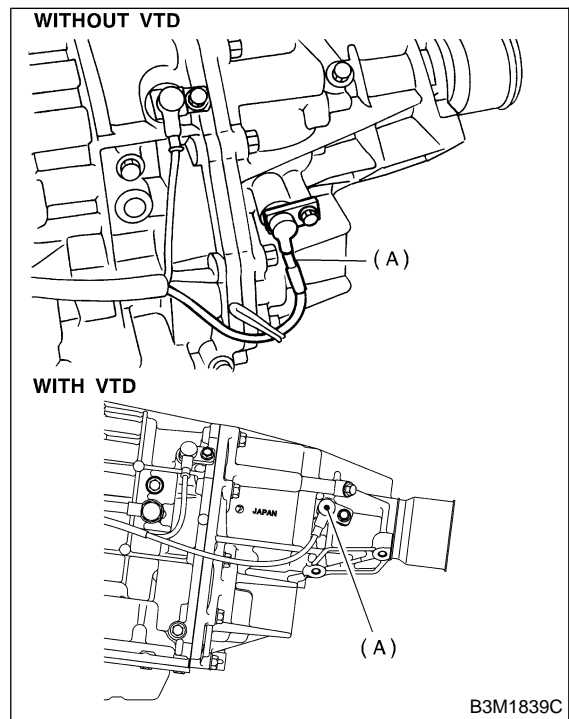

(A) Rear vehicle speed sensor

## C: DISASSEMBLY S510587A06

### 1. WITHOUT VTD S510587A0601

1) Take out the transfer clutch by lightly tapping the end of the rear drive shaft.

**NOTE:**

Be careful not to damage the oil seal in the extension.

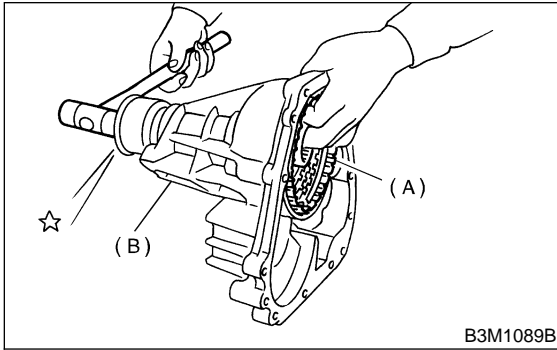

- (A) Extension case
- (B) Transfer clutch

2) Remove the transfer clutch pipe.

**CAUTION:**

Be careful not to bend the pipe.

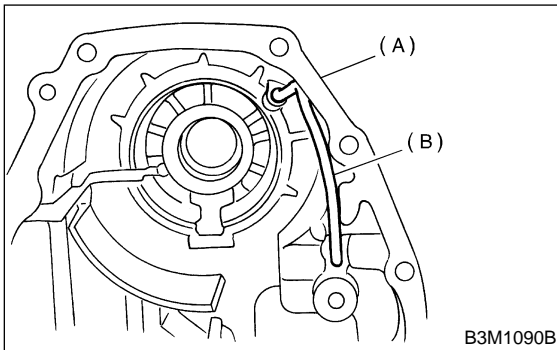

- (A) Extension case
- (B) Transfer clutch pipe

3) Remove the dust cover from the extension case.

4) Remove the oil seal from the extension case.

### 2. WITH VTD S510587A0602

1) Using ST1, ST2, ST3 and a press, remove snap ring.

ST1 398673600 COMPRESSOR

ST2 498627100 SEAT

ST3 398663600 PLIERS

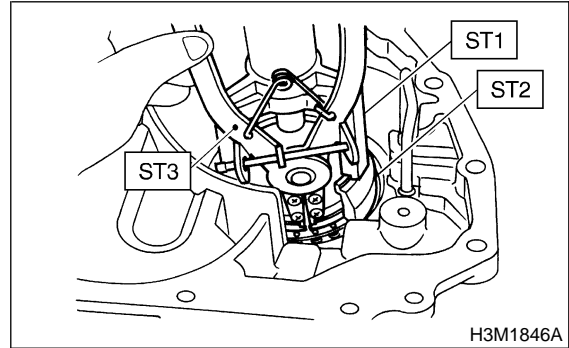

2) Remove test plug.

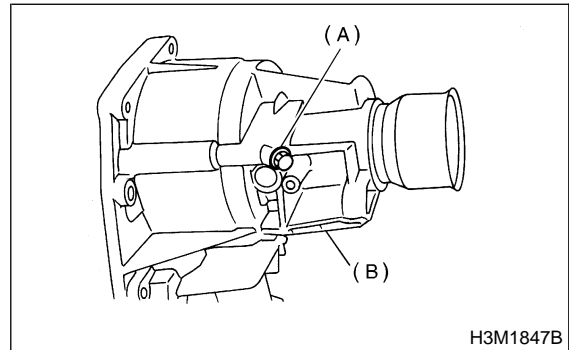

- (A) Extension case
- (B) Test plug

3) Remove clutch piston by compressed air.

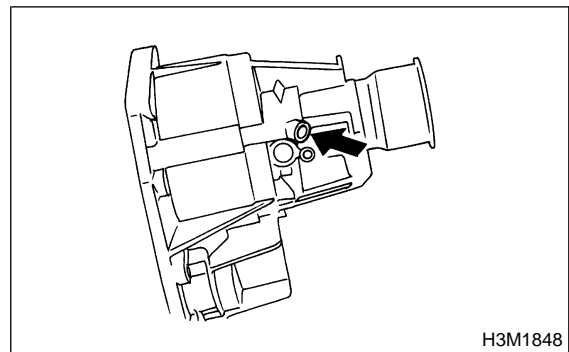

# EXTENSION CASE

Automatic Transmission

4) Remove transfer clutch pipe.

NOTE:

Be careful not to bend the pipe.

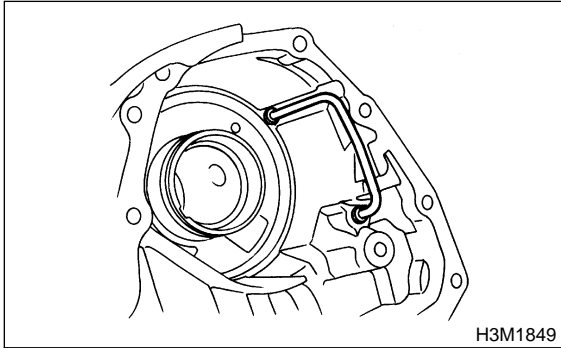

5) Remove the dust cover from the extension case.

6) Remove the oil seal from the extension case.

## D: ASSEMBLY S510587A02

### 1. WITHOUT VTD S510587A0201

1) Using the ST and a press, press in a new oil seal.

ST 498057300 INSTALLER

2) Press in the dust cover.

3) Install the transfer pipe to extension case.

NOTE:

Be careful not to bend the pipe.

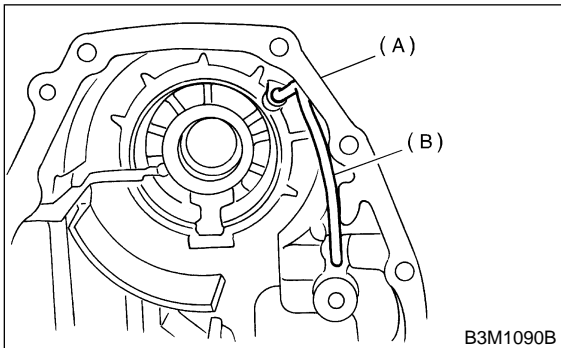

(A) Extension case

(B) Transfer pipe

4) Install the transfer clutch assembly to the case.

NOTE:

- Be careful not to damage the seal rings.
- Insert the clutch assembly fully into position until the bearing shoulder bottoms.

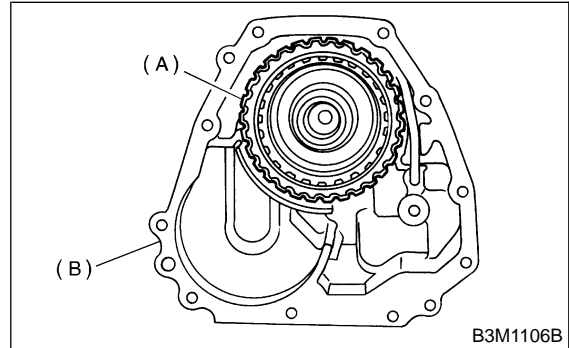

(A) Transfer clutch

(B) Extension case

### 2. WITH VTD S510587A0202

1) Using the ST and a press, press in a new oil seal.

ST 498057300 INSTALLER

2) Press in the dust cover.

3) Install transfer clutch pipe.

NOTE:

Be careful not to bend the pipe.

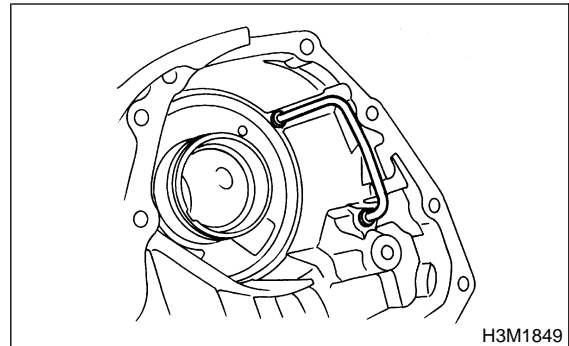

4) Install test plug.

**Tightening torque:**

**13 N·m (1.3 kgf·m, 9.4 ft·lb)**

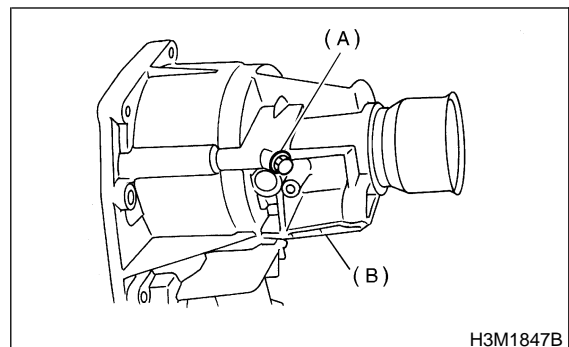

(A) Test plug

(B) Extension case

5) Insert the multi-plate clutch, the drive plate, the driven plate, and the spring retainer.

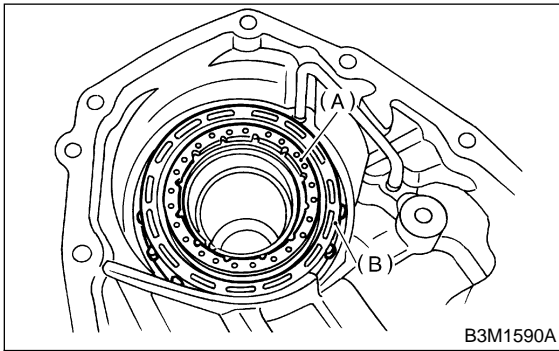

- (A) Spring retainer
- (B) Multi-plate clutch (LSD) piston ASSY

6) Using the ST1, ST2, and ST3, install the snap ring.

- ST1 398673600 COMPRESSOR
- ST2 498627100 SEAT
- ST3 398663600 PLIERS

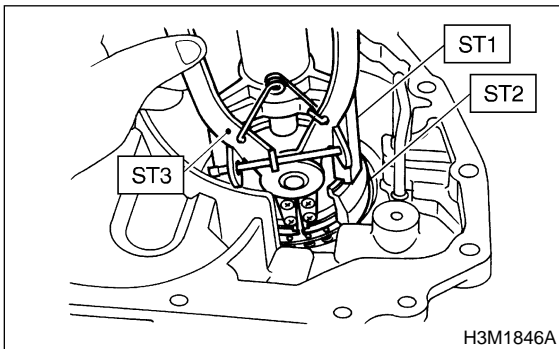

## E: INSPECTION S510587A10

- Use forced air to make sure the transfer pipe and extension case routes are not clogged and do not leak.

- Measure the extension end play and adjust it to within specifications.

Without VTD <Ref. to AT-44, WITHOUT VTD, ADJUSTMENT, Transfer Clutch.>

With VTD <Ref. to AT-44, WITH VTD, ADJUSTMENT, Transfer Clutch.>

# TRANSFER CLUTCH

Automatic Transmission

## 9. Transfer Clutch S510588

### A: REMOVAL S510588A18

- 1) Remove rear vehicle speed sensor.

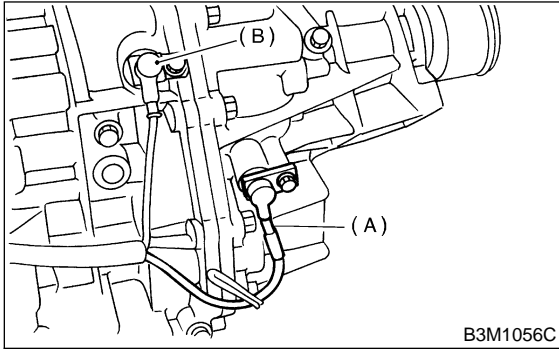

- (A) Rear vehicle speed sensor
- (B) Front vehicle speed sensor

- 2) Separate transmission case and extension case sections.

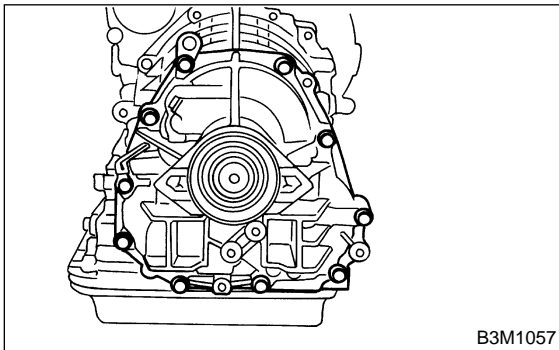

- 3) Take out the transfer clutch by lightly tapping the end of the rear drive shaft.

NOTE:

Be careful not to damage the oil seal in the extension.

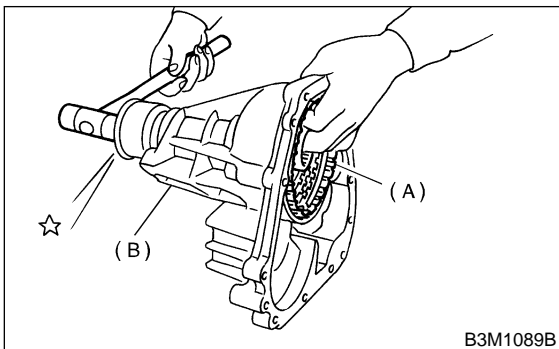

- (A) Transfer clutch
- (B) Extension case

### B: INSTALLATION S510588A11

- 1) Install the transfer clutch assembly to the case.

NOTE:

Be careful not to damage the seal rings.

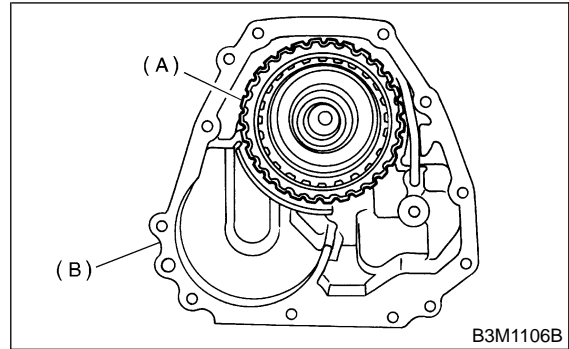

- (A) Transfer clutch
- (B) Extension case

- 2) Tighten bolts to secure the case.

**Tightening torque:**

**25 N·m (2.5 kgf·m, 18.1 ft·lb)**

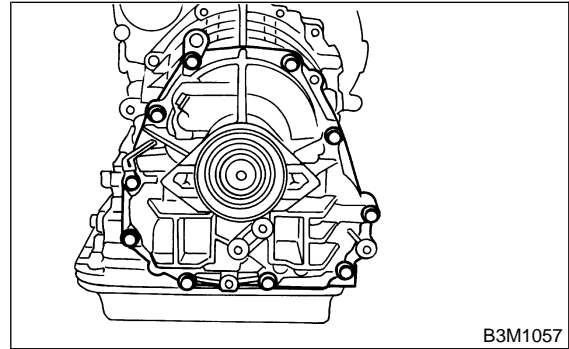

### C: DISASSEMBLY S510588A06

- 1) Remove the seal ring.

NOTE:

Do not re-use seal ring. Prepare a new one.

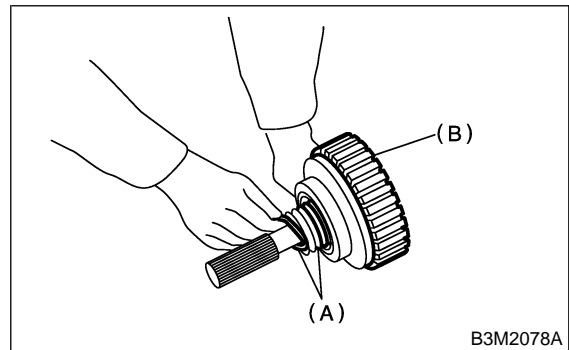

- (A) Seal ring
- (B) Transfer clutch

# TRANSFER CLUTCH

Automatic Transmission

2) Using a press and ST, remove the ball bearing.

NOTE:

Do not reuse the bearing.

ST 498077600 REMOVER

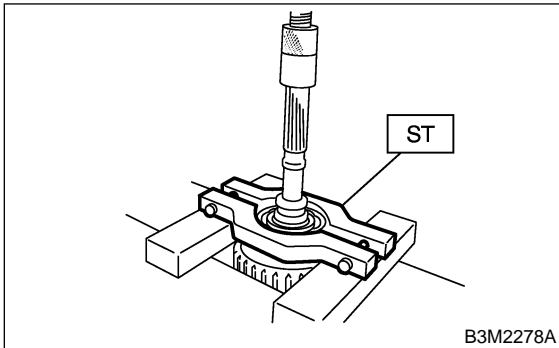

3) Remove the snap ring, and take out the pressure plate, drive plates, and driven plates.

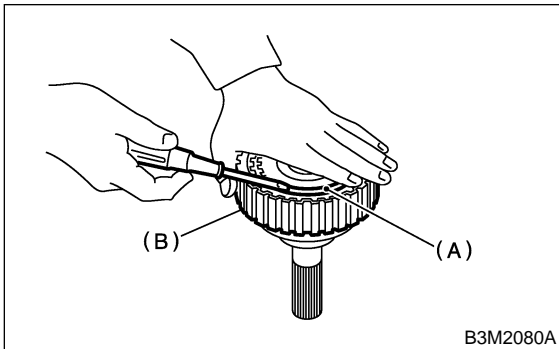

- (A) Snap ring
- (B) Transfer clutch

4) Remove the snap ring with ST1, ST2 and ST3, and take out the return spring and transfer clutch piston seal.

ST1 399893600 PLIERS  
ST2 398673600 COMPRESSOR  
ST3 398623600 SEAT

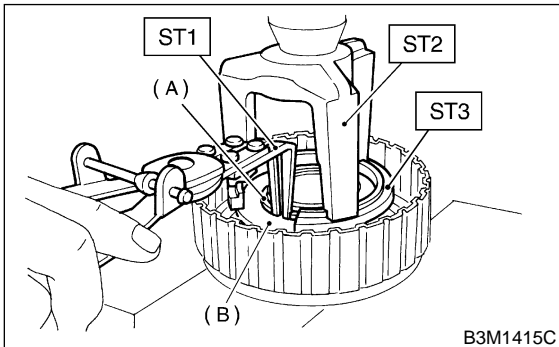

- (A) Snap ring
- (B) Transfer piston seal

5) Apply compressed air to the rear drive shaft to remove the piston.

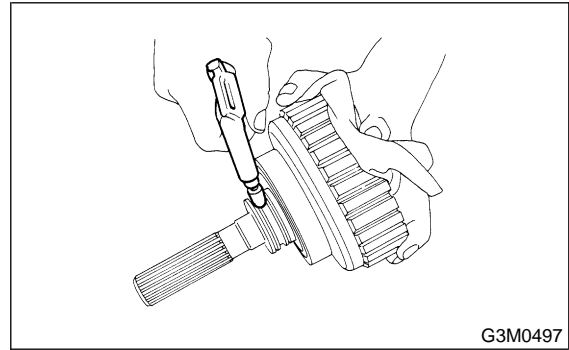

## D: ASSEMBLY S510588A02

1) Install the transfer clutch piston.

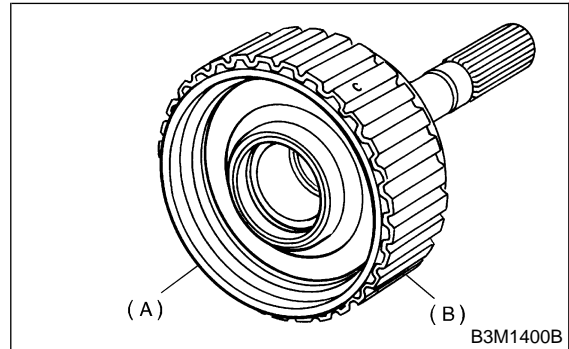

- (A) Transfer clutch piston
- (B) Rear drive shaft

2) Install return spring to transfer piston.

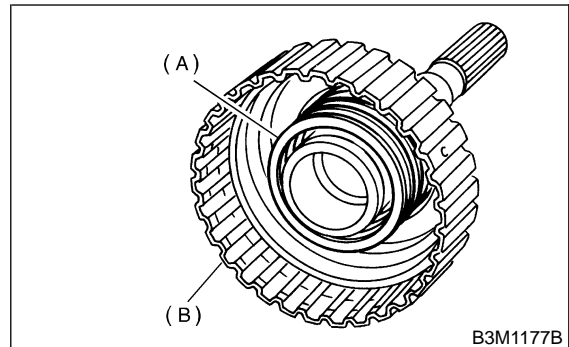

- (A) Return spring
- (B) Rear drive shaft

# TRANSFER CLUTCH

Automatic Transmission

3) Install transfer clutch piston seal.

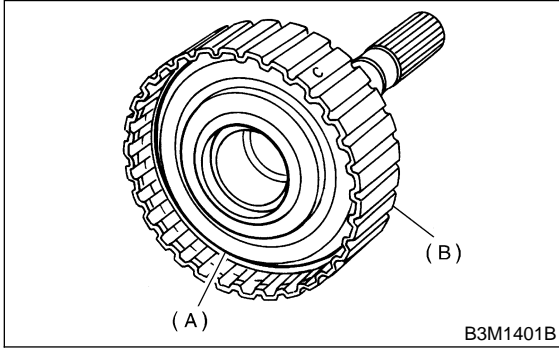

4) Install ST to rear drive shaft.  
ST 499257300 SNAP RING OUTER GUIDE

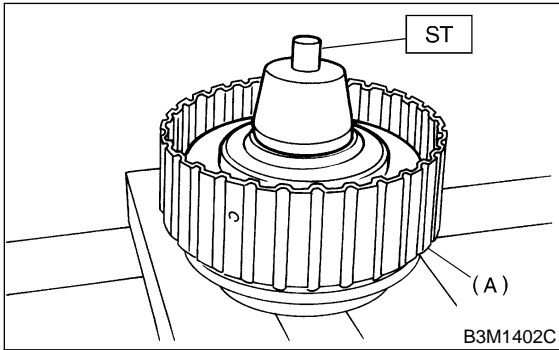

5) Install snap ring to ST.  
ST 499257300 SNAP RING OUTER GUIDE

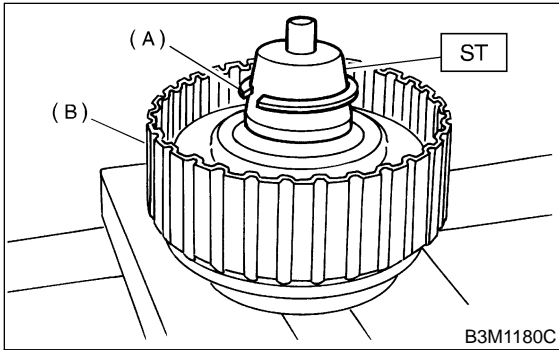

6) Using ST1 and ST2, install snap ring to rear drive shaft.

NOTE:

After installing snap ring, remove ST1 and ST2.

ST1 499257300 SNAP RING OUTER GUIDE  
ST2 499247400 INSTALLER

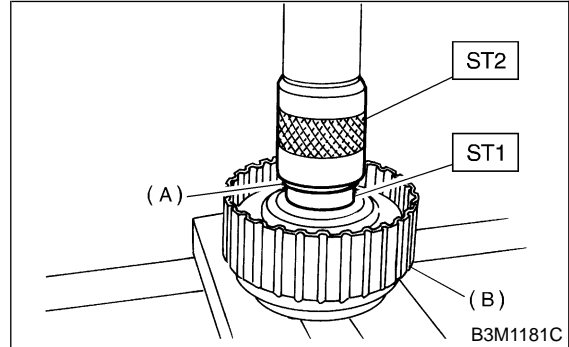

7) Install the driven plates, drive plates, pressure plate and snap ring.

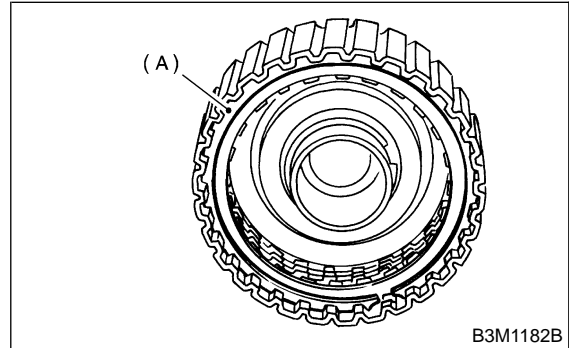

8) Apply compressed air to see if the assembled parts move smoothly.

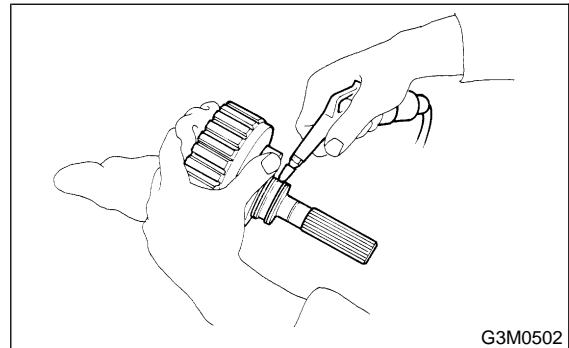

9) Check clearance between snap ring and pressure plate. <Ref. to AT-43, INSPECTION, Transfer Clutch.>

10) Press-fit the ball bearing with ST.  
ST 899580100 INSTALLER

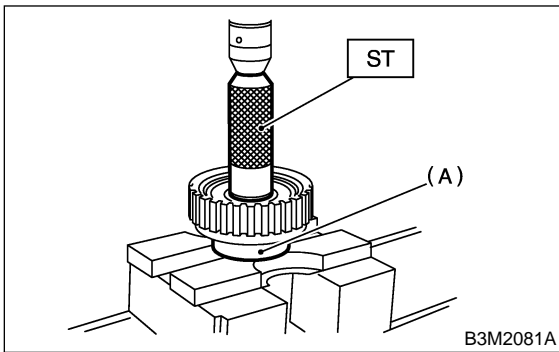

(A) Ball bearing

11) Coat the seal ring with vaseline, and install it in the seal ring groove of the shaft.

**NOTE:**

Do not expand the seal ring excessively when installing.

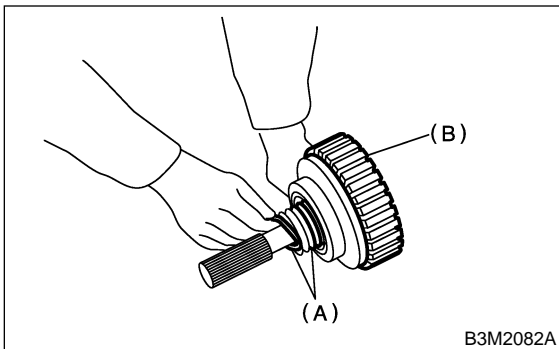

(A) Seal rings  
(B) Transfer clutch

12) Install the transfer clutch assembly to the case.

**NOTE:**

Be careful not to damage the seal rings.

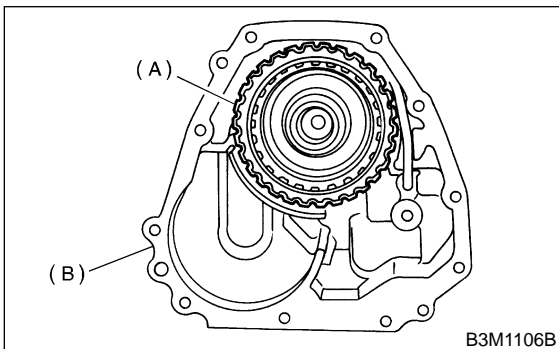

(A) Transfer clutch  
(B) Extension case

- Check the snap ring for wear, return spring for permanent set and breakage, and return spring for deformation.
- Check the lathe cut ring for damage.
- Measure the extension end play and adjust it to within specifications.

WITHOUT VTD <Ref. to AT-44, WITHOUT VTD, ADJUSTMENT, Transfer Clutch.>

WITH VTD <Ref. to AT-44, WITH VTD, ADJUSTMENT, Transfer Clutch.>

- 1) Inspect clearance between snap ring and pressure plate.

**NOTE:**

- Before measuring clearance, place the same thickness of shim on both sides to prevent pressure plate from tilting.

- If the clearance is not within specification, adjust it by selecting a suitable pressure plate on the transfer clutch piston side.

**Standard value:**

**0.7 — 1.1 mm (0.028 — 0.043 in)**

**Allowable limit:**

**1.6 mm (0.063 in)**

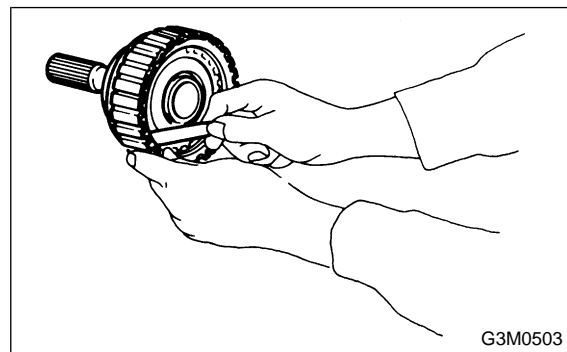

Available pressure plates	
Part No.	Thickness mm (in)
31593AA151	3.3 (0.130)
31593AA161	3.7 (0.146)
31593AA171	4.1 (0.161)
31593AA181	4.5 (0.177)

**E: INSPECTION** SS10588A10

- Check the drive plate facing for wear and damage.



# TRANSFER CLUTCH

Automatic Transmission

## F: ADJUSTMENT S510588A01

### 1. WITHOUT VTD S510588A0101

1) Measure distance “L” from end of extension case and rear drive shaft with ST.

ST 398643600 GAUGE

L = Measured value – 15 mm

(L = Measured value – 0.59 in)

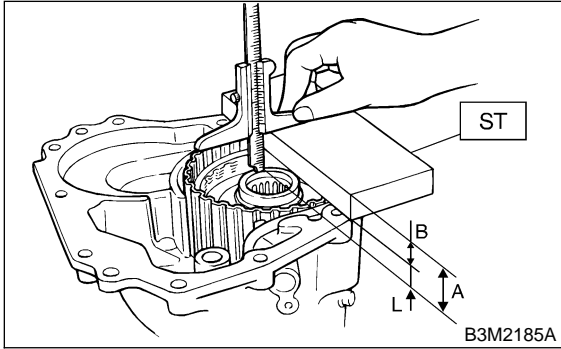

A: Measured value

B: ST thickness [15 mm (0.59 in)]

L: Distance from end of extension case to end of rear drive shaft

2) Measure the distance “ℓ” from the transmission case mating surface to the reduction drive gear end surface with ST1 and ST2.

ℓ = Measured value – 50 mm

(ℓ = Measured value – 1.97 in)

ST1 398643600 GAUGE

ST2 499577000 GAUGE

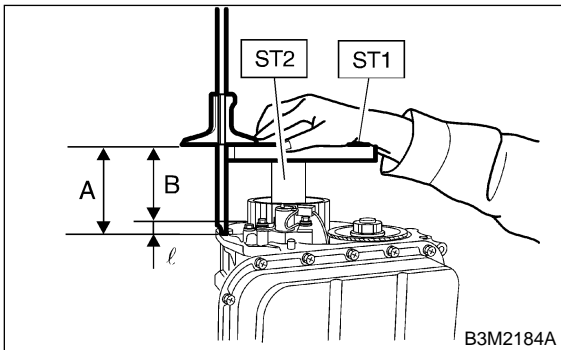

A: Measured value

B: ST thickness [50 mm (1.97 in)]

ℓ: Distance from end of transmission case to end of reduction drive gear

3) Calculation equation:

NOTE:

Calculate “H”:

When clearance is at 0.05 mm (0.0020 in) and 0.25 mm (0.0098 in), then select a suitable thrust needle bearing from the table.

$$H = (L + 0.45 \text{ mm}) - \ell - T$$

$$[H = (L + 0.0177 \text{ in}) - \ell - T]$$

T: Thrust needle bearing thickness

L: Distance from end of extension case to end of rear drive shaft

0.45 mm (0.0177 in): Gasket thickness

ℓ: Distance from end of transmission case to end of reduction drive gear

H: Shim clearance

0.05 — 0.25 mm (0.0020 — 0.0098 in)

Example:

When, L = 18.60 mm (0.7323 in), ℓ = 15.05 mm (0.5925 in)

Calculation when clearance is 0.05 mm (0.0020 in)

$$H = (18.60 + 0.45) - 15.05 - 0.05 = 3.95$$

$$[H = (0.7323 + 0.0177) - 0.5925 - 0.0020 = 0.1555]$$

Calculation when clearance is 0.25 mm (0.0098 in)

$$H = (18.60 + 0.45) - 15.05 - 0.25 = 3.75$$

$$[H = (0.7323 + 0.0177) - 0.5925 - 0.0098 = 0.1476]$$

After calculation, the value of “H” becomes between 3.75 and 3.95, therefore select bearing thickness of 3.8.

Thrust needle bearing	
Part No.	Thickness mm (in)
806536020	3.8 (0.150)
806535030	4.0 (0.157)
806535040	4.2 (0.165)
806535050	4.4 (0.173)
806535060	4.6 (0.181)
806535070	4.8 (0.189)
806535090	5.0 (0.197)

### 2. WITH VTD S510588A0102

1) Install the rear drive shaft into the reduction drive gear and center differential assembly.

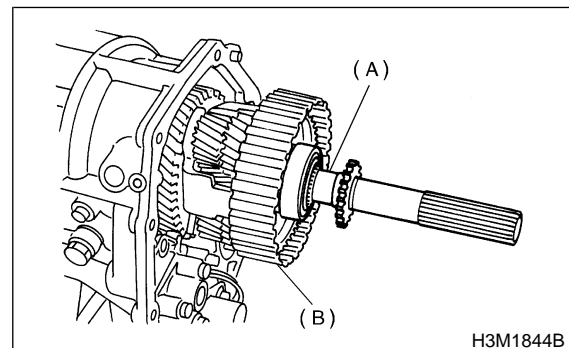

(A) Rear drive plate

(B) Center differential carrier

# TRANSFER CLUTCH

Automatic Transmission

2) Measure the distance "L" from mating surface of extension case to multi-plate clutch (LSD) piston with ST.

ST 398643600 GAUGE

L = Measured value - 15 mm

(L = Measured value - 0.59 in)

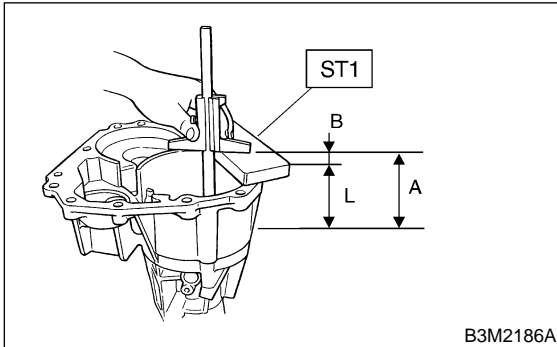

A: Measured value

B: ST thickness [15 mm (0.59 in)]

L: Distance from end of extension case to end of rear drive shaft

3) Measure the distance "ℓ" from the transmission case mating surface to the reduction drive gear end surface with ST.

ℓ = Measured value - 15 mm

(ℓ = Measured value - 0.59 in)

ST 398643600 GAUGE

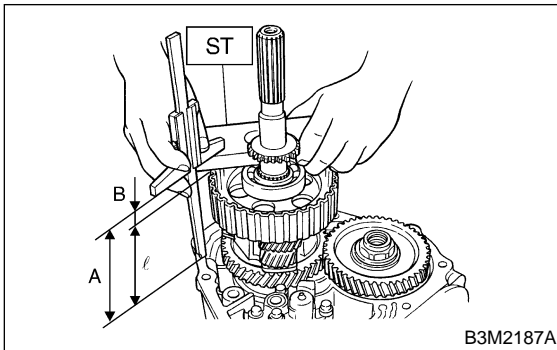

A: Measured value

B: ST thickness [15 mm (0.59 in)]

ℓ: Distance from end of extension case to end of reduction drive gear

4) Calculation equation:

NOTE:

Calculate "H":

When clearance is at 0.05 mm (0.0020 in) and 0.25 mm (0.0098 in), then select no more than 4 adjusting shims from the table which suit the clearance value.

$$H = (L + 0.45 \text{ mm}) - \ell - T$$

$$[H = (L + 0.0177 \text{ in}) - \ell - T]$$

T: Shim clearance

L: Distance from end of extension case to end of rear drive shaft

0.45 mm (0.0177 in): Gasket thickness

ℓ: Distance from end of transmission case to end of reduction drive gear

T: Shim thickness

0.05 — 0.25 mm (0.0020 — 0.0098 in)

Example:

When, L = 90.50 mm (3.5630 in), ℓ = 90.35 mm (3.5571 in)

Calculation when clearance is 0.05 mm (0.0020 in)

$$H = (90.50 + 0.45) - 90.35 - 0.05 = 0.55$$

$$[H = (3.5630 + 0.0177) - 3.5571 - 0.0020 = 0.0217]$$

Calculation when clearance is 0.25 mm (0.0098 in)

$$H = (90.50 + 0.45) - 90.35 - 0.25 = 0.35$$

$$[H = (3.5630 + 0.0177) - 3.5571 - 0.0098 = 0.0138]$$

After calculation, the value of "H" falls between 0.35 mm (0.0138 in) and 0.55 mm (0.0216 in), therefore select a two-piece shim thickness of 0.2 mm (0.010 in) or 1 piece at 0.5 mm (0.020 in).

Adjusting shim	
Part No.	Thickness mm (in)
33281AA001	0.2 (0.008)
33281AA011	0.5 (0.020)

# TRANSFER CLUTCH

Automatic Transmission

## 9. Transfer Clutch S510588

### A: REMOVAL S510588A18

1) Remove rear vehicle speed sensor.

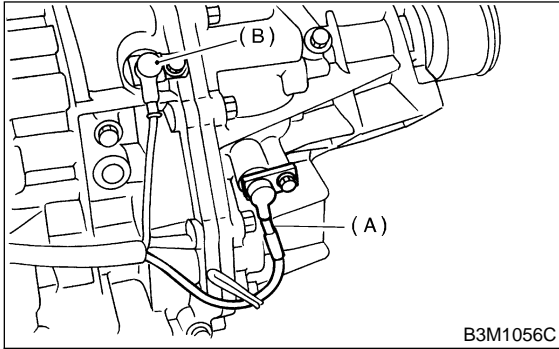

- (A) Rear vehicle speed sensor
- (B) Front vehicle speed sensor

2) Separate transmission case and extension case sections.

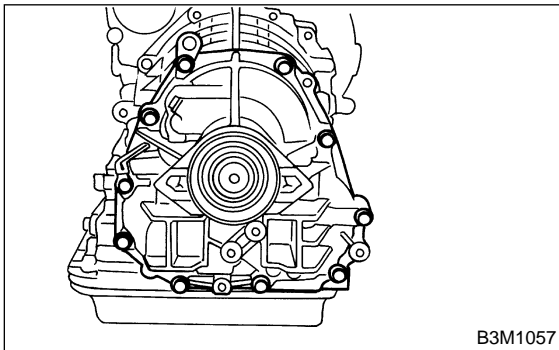

3) Take out the transfer clutch by lightly tapping the end of the rear drive shaft.

NOTE:

Be careful not to damage the oil seal in the extension.

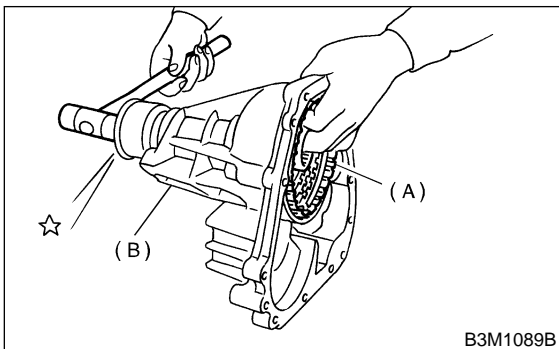

- (A) Transfer clutch
- (B) Extension case

### B: INSTALLATION S510588A11

1) Install the transfer clutch assembly to the case.

NOTE:

Be careful not to damage the seal rings.

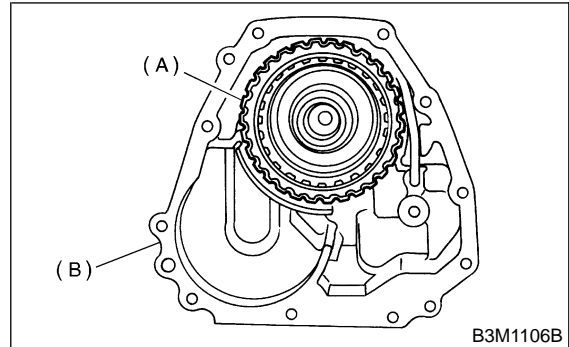

- (A) Transfer clutch
- (B) Extension case

2) Tighten bolts to secure the case.

**Tightening torque:**

**25 N·m (2.5 kgf·m, 18.1 ft·lb)**

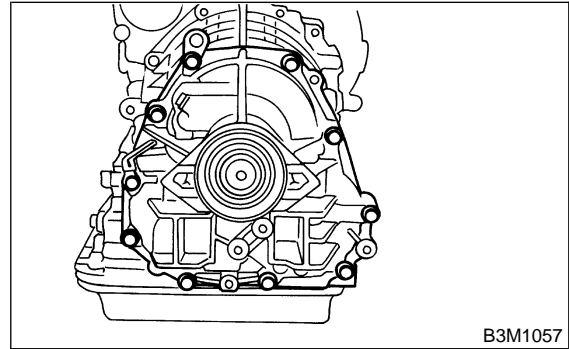

### C: DISASSEMBLY S510588A06

1) Remove the seal ring.

NOTE:

Do not re-use seal ring. Prepare a new one.

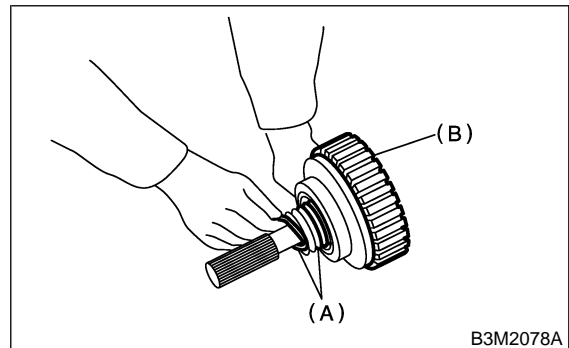

- (A) Seal ring
- (B) Transfer clutch

# TRANSFER CLUTCH

Automatic Transmission

2) Using a press and ST, remove the ball bearing.

NOTE:

Do not reuse the bearing.

ST 498077600 REMOVER

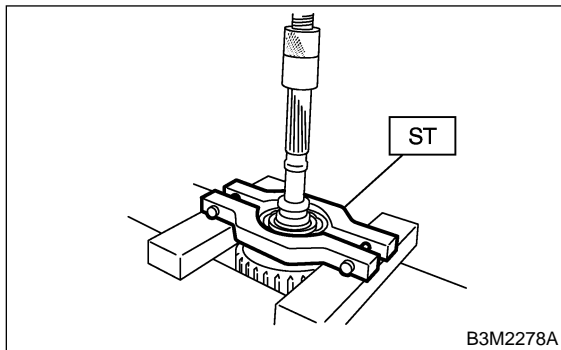

3) Remove the snap ring, and take out the pressure plate, drive plates, and driven plates.

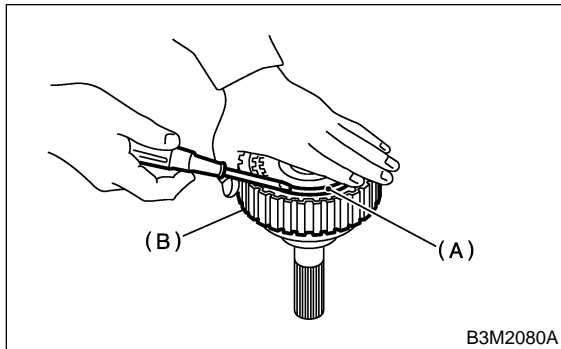

- (A) Snap ring
- (B) Transfer clutch

4) Remove the snap ring with ST1, ST2 and ST3, and take out the return spring and transfer clutch piston seal.

ST1 399893600 PLIERS  
ST2 398673600 COMPRESSOR  
ST3 398623600 SEAT

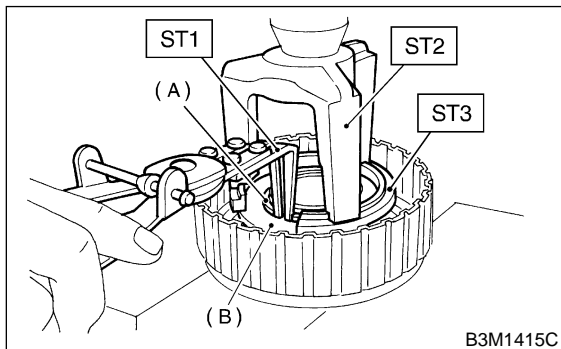

- (A) Snap ring
- (B) Transfer piston seal

5) Apply compressed air to the rear drive shaft to remove the piston.

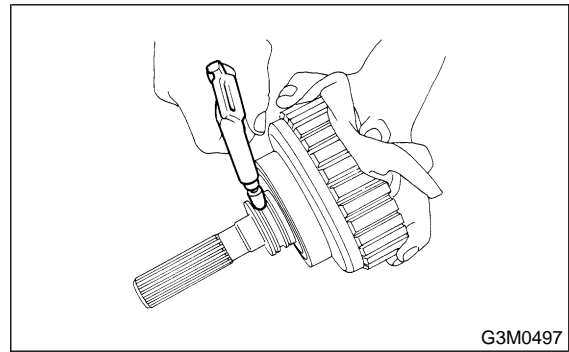

## D: ASSEMBLY S510588A02

1) Install the transfer clutch piston.

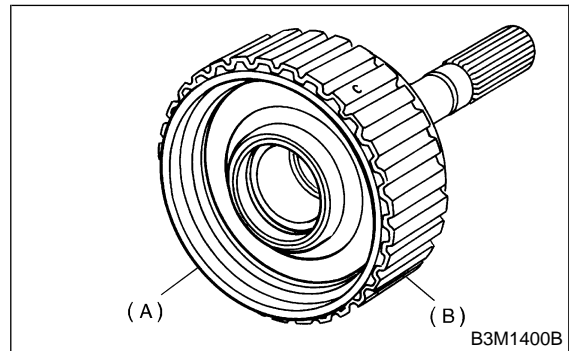

- (A) Transfer clutch piston
- (B) Rear drive shaft

2) Install return spring to transfer piston.

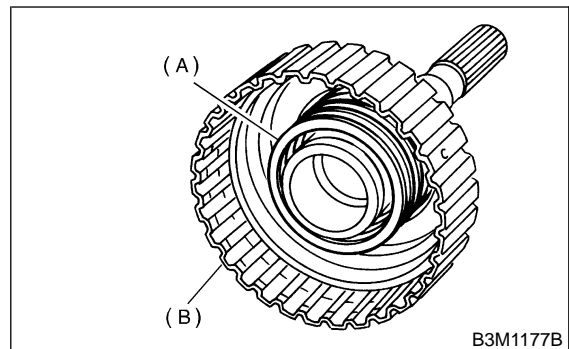

- (A) Return spring
- (B) Rear drive shaft

# TRANSFER CLUTCH

Automatic Transmission

3) Install transfer clutch piston seal.

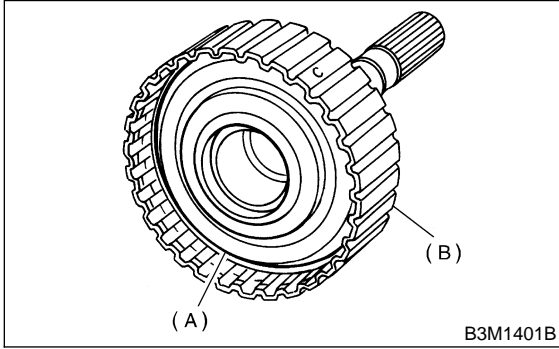

4) Install ST to rear drive shaft.  
ST 499257300 SNAP RING OUTER GUIDE

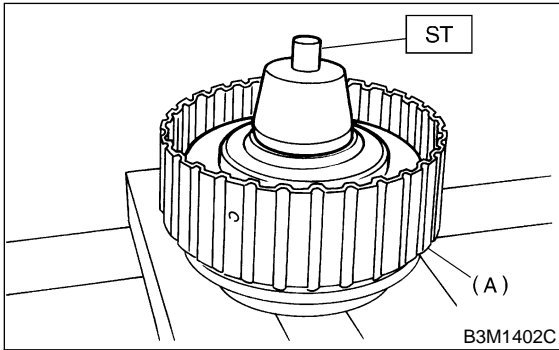

5) Install snap ring to ST.  
ST 499257300 SNAP RING OUTER GUIDE

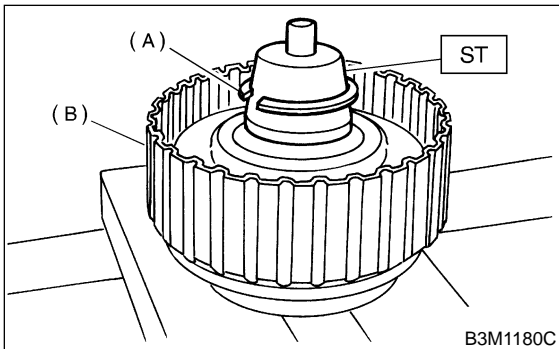

6) Using ST1 and ST2, install snap ring to rear drive shaft.

NOTE:

After installing snap ring, remove ST1 and ST2.

ST1 499257300 SNAP RING OUTER GUIDE  
ST2 499247400 INSTALLER

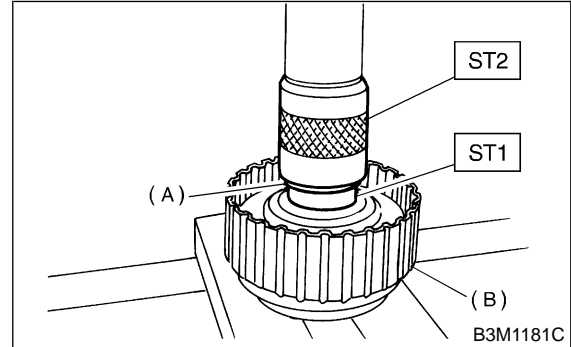

7) Install the driven plates, drive plates, pressure plate and snap ring.

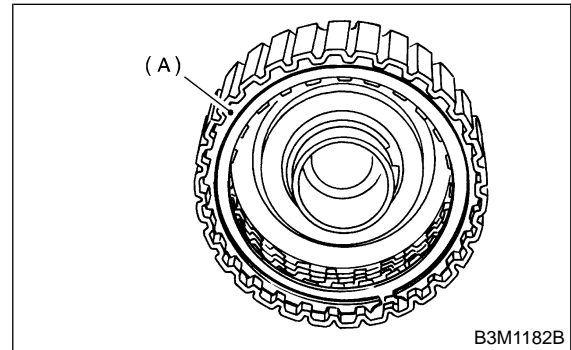

8) Apply compressed air to see if the assembled parts move smoothly.

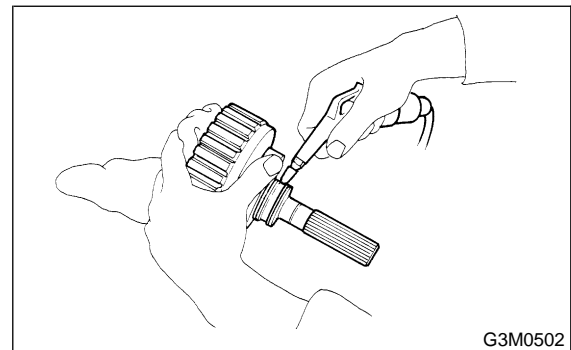

9) Check clearance between snap ring and pressure plate. <Ref. to AT-43, INSPECTION, Transfer Clutch.>

10) Press-fit the ball bearing with ST.  
ST 899580100 INSTALLER

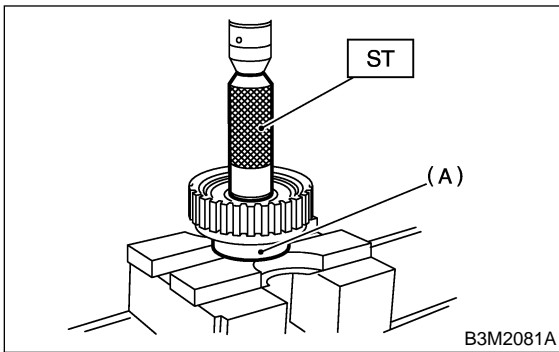

(A) Ball bearing

11) Coat the seal ring with vaseline, and install it in the seal ring groove of the shaft.

**NOTE:**

Do not expand the seal ring excessively when installing.

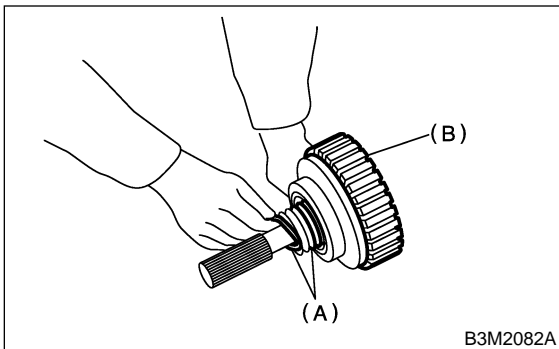

(A) Seal rings  
(B) Transfer clutch

12) Install the transfer clutch assembly to the case.

**NOTE:**

Be careful not to damage the seal rings.

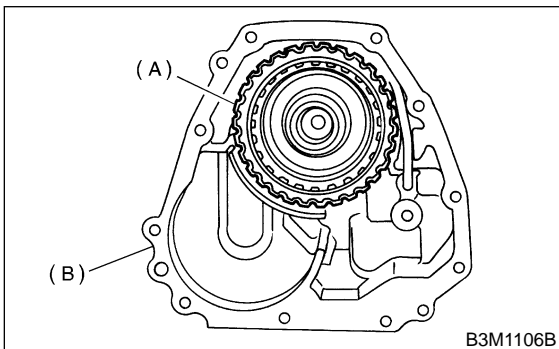

(A) Transfer clutch  
(B) Extension case

- Check the snap ring for wear, return spring for permanent set and breakage, and return spring for deformation.
- Check the lathe cut ring for damage.
- Measure the extension end play and adjust it to within specifications.

WITHOUT VTD <Ref. to AT-44, WITHOUT VTD, ADJUSTMENT, Transfer Clutch.>

WITH VTD <Ref. to AT-44, WITH VTD, ADJUSTMENT, Transfer Clutch.>

- 1) Inspect clearance between snap ring and pressure plate.

**NOTE:**

- Before measuring clearance, place the same thickness of shim on both sides to prevent pressure plate from tilting.

- If the clearance is not within specification, adjust it by selecting a suitable pressure plate on the transfer clutch piston side.

**Standard value:**

**0.7 — 1.1 mm (0.028 — 0.043 in)**

**Allowable limit:**

**1.6 mm (0.063 in)**

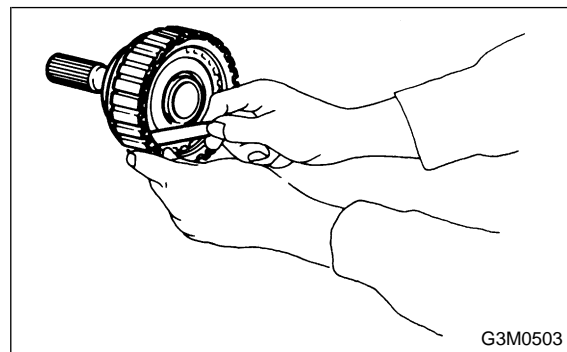

Available pressure plates	
Part No.	Thickness mm (in)
31593AA151	3.3 (0.130)
31593AA161	3.7 (0.146)
31593AA171	4.1 (0.161)
31593AA181	4.5 (0.177)

**E: INSPECTION** SS10588A10

- Check the drive plate facing for wear and damage.

# TRANSFER CLUTCH

Automatic Transmission

## F: ADJUSTMENT S510588A01

### 1. WITHOUT VTD S510588A0101

1) Measure distance “L” from end of extension case and rear drive shaft with ST.

ST 398643600 GAUGE

L = Measured value – 15 mm

(L = Measured value – 0.59 in)

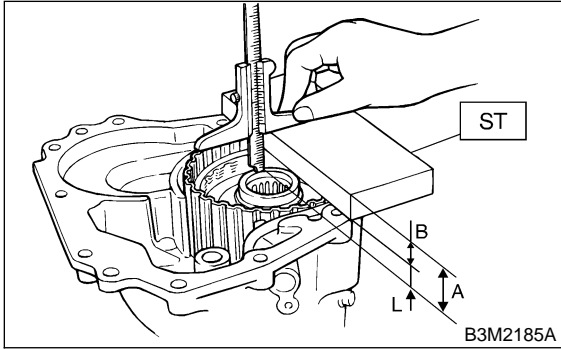

A: Measured value

B: ST thickness [15 mm (0.59 in)]

L: Distance from end of extension case to end of rear drive shaft

2) Measure the distance “ℓ” from the transmission case mating surface to the reduction drive gear end surface with ST1 and ST2.

ℓ = Measured value – 50 mm

(ℓ = Measured value – 1.97 in)

ST1 398643600 GAUGE

ST2 499577000 GAUGE

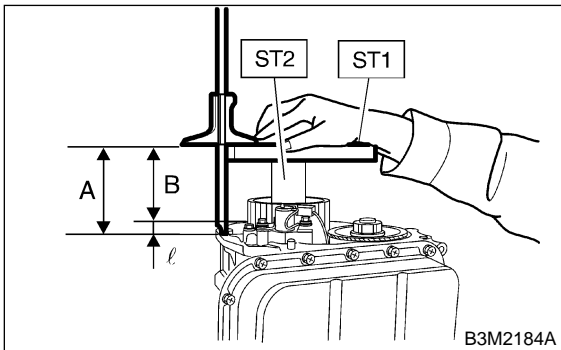

A: Measured value

B: ST thickness [50 mm (1.97 in)]

ℓ: Distance from end of transmission case to end of reduction drive gear

3) Calculation equation:

NOTE:

Calculate “H”:

When clearance is at 0.05 mm (0.0020 in) and 0.25 mm (0.0098 in), then select a suitable thrust needle bearing from the table.

$$H = (L + 0.45 \text{ mm}) - \ell - T$$

$$[H = (L + 0.0177 \text{ in}) - \ell - T]$$

T: Thrust needle bearing thickness

L: Distance from end of extension case to end of rear drive shaft

0.45 mm (0.0177 in): Gasket thickness

ℓ: Distance from end of transmission case to end of reduction drive gear

H: Shim clearance

0.05 — 0.25 mm (0.0020 — 0.0098 in)

Example:

When, L = 18.60 mm (0.7323 in), ℓ = 15.05 mm (0.5925 in)

Calculation when clearance is 0.05 mm (0.0020 in)

$$H = (18.60 + 0.45) - 15.05 - 0.05 = 3.95$$

$$[H = (0.7323 + 0.0177) - 0.5925 - 0.0020 = 0.1555]$$

Calculation when clearance is 0.25 mm (0.0098 in)

$$H = (18.60 + 0.45) - 15.05 - 0.25 = 3.75$$

$$[H = (0.7323 + 0.0177) - 0.5925 - 0.0098 = 0.1476]$$

After calculation, the value of “H” becomes between 3.75 and 3.95, therefore select bearing thickness of 3.8.

Thrust needle bearing	
Part No.	Thickness mm (in)
806536020	3.8 (0.150)
806535030	4.0 (0.157)
806535040	4.2 (0.165)
806535050	4.4 (0.173)
806535060	4.6 (0.181)
806535070	4.8 (0.189)
806535090	5.0 (0.197)

### 2. WITH VTD S510588A0102

1) Install the rear drive shaft into the reduction drive gear and center differential assembly.

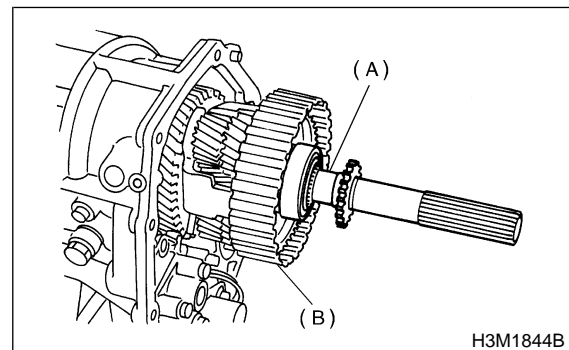

(A) Rear drive plate

(B) Center differential carrier

# TRANSFER CLUTCH

Automatic Transmission

2) Measure the distance "L" from mating surface of extension case to multi-plate clutch (LSD) piston with ST.

ST 398643600 GAUGE

L = Measured value - 15 mm

(L = Measured value - 0.59 in)

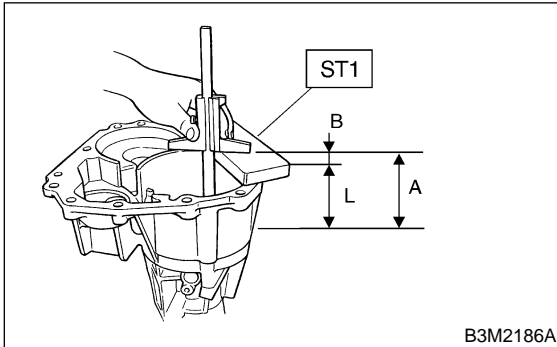

A: Measured value

B: ST thickness [15 mm (0.59 in)]

L: Distance from end of extension case to end of rear drive shaft

3) Measure the distance "ℓ" from the transmission case mating surface to the reduction drive gear end surface with ST.

ℓ = Measured value - 15 mm

(ℓ = Measured value - 0.59 in)

ST 398643600 GAUGE

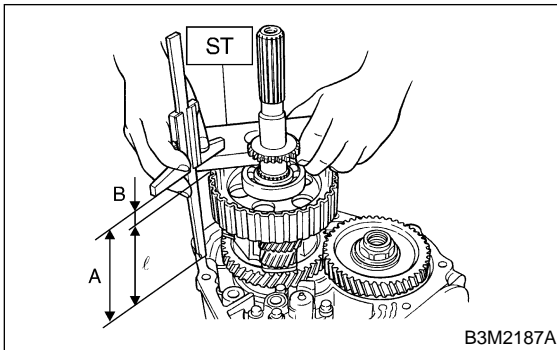

A: Measured value

B: ST thickness [15 mm (0.59 in)]

ℓ: Distance from end of extension case to end of reduction drive gear

4) Calculation equation:

NOTE:

Calculate "H":

When clearance is at 0.05 mm (0.0020 in) and 0.25 mm (0.0098 in), then select no more than 4 adjusting shims from the table which suit the clearance value.

$$H = (L + 0.45 \text{ mm}) - \ell - T$$

$$[H = (L + 0.0177 \text{ in}) - \ell - T]$$

T: Shim clearance

L: Distance from end of extension case to end of rear drive shaft

0.45 mm (0.0177 in): Gasket thickness

ℓ: Distance from end of transmission case to end of reduction drive gear

T: Shim thickness

0.05 — 0.25 mm (0.0020 — 0.0098 in)

Example:

When, L = 90.50 mm (3.5630 in), ℓ = 90.35 mm (3.5571 in)

Calculation when clearance is 0.05 mm (0.0020 in)

$$H = (90.50 + 0.45) - 90.35 - 0.05 = 0.55$$

$$[H = (3.5630 + 0.0177) - 3.5571 - 0.0020 = 0.0217]$$

Calculation when clearance is 0.25 mm (0.0098 in)

$$H = (90.50 + 0.45) - 90.35 - 0.25 = 0.35$$

$$[H = (3.5630 + 0.0177) - 3.5571 - 0.0098 = 0.0138]$$

After calculation, the value of "H" falls between 0.35 mm (0.0138 in) and 0.55 mm (0.0216 in), therefore select a two-piece shim thickness of 0.2 mm (0.010 in) or 1 piece at 0.5 mm (0.020 in).

Adjusting shim	
Part No.	Thickness mm (in)
33281AA001	0.2 (0.008)
33281AA011	0.5 (0.020)



# MULTI-PLATE CLUTCH

Automatic Transmission

## 10. Multi-plate Clutch S510589

### A: REMOVAL S510589A18

The multi-plate clutch is removed in the same way that the extension case is removed. <Ref. to AT-36, REMOVAL, Extension Case.>

### B: INSTALLATION S510589A11

The multi-plate clutch is installed in the same way that the extension case is installed. <Ref. to AT-36, INSTALLATION, Extension Case.>

### C: INSPECTION S510589A10

- Check the drive plate facing for wear and damage.
- Check the snap ring for wear, return spring for permanent set and breakage, and return spring for deformation.
- Check the lathe cut ring for damage.
- Measure the clearance of the multi-plate clutch and adjust it to within specifications. <Ref. to AT-46, ADJUSTMENT, Multi-plate Clutch.>

### D: ADJUSTMENT S510589A01

- 1) Remove the drive plate and driven plate from the center differential carrier.
- 2) Measure the distance "L" from mating surface of extension case to multi-plate clutch (LSD) piston with ST.

ST 398643600 GAUGE

L = Measured value - 15 mm  
(L = Measured value - 0.59 in)

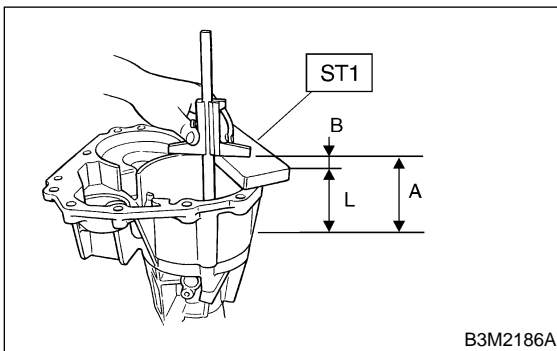

A: Measured value  
B: ST thickness [15 mm (0.59 in)]  
L: Distance from end of extension case to end of rear drive shaft

- 3) Measure the height "ℓ" from mating surface of the transmission case to end surface of the center differential clutch drum with ST.  
ST 398744300 GAUGE  
ℓ = Measured value - 50 mm  
(ℓ = Measured value - 1.97 in)

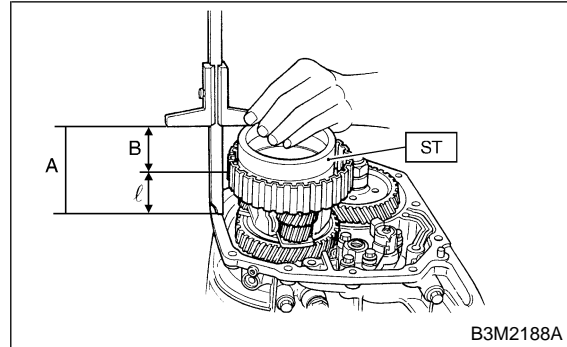

- A: Measured value  
B: ST thickness [50 mm (1.97 in)]  
ℓ: Distance from mating surface of transmission case to multi-plate clutch (LSD) piston

- 4) Calculation equation:

$$T = (L + 0.45 \text{ mm}) - \ell$$

$$[T = (L + 0.0177 \text{ in}) - \ell]$$

T: Measurements between end surface of clutch drum and multi-plate clutch (LSD) piston.

L: Distance from mating surface of extension case to multi-plate clutch (LSD) piston.

0.45: Gasket thickness

ℓ: Distance from mating surface of transmission case to end surface of the center differential clutch drum.

#### NOTE:

Measure thickness of driven and drive plates of multi-plate clutch (LSD) and determine clearance between measured value and "T".

#### Standard value:

**0.2 — 0.6 mm (0.008 — 0.024 in)**

#### Allowable limit:

**1.6 mm (0.063 in)**

If out of specification, replace plate set (drive and driven plate) and select a multi-plate clutch (LSD) piston side adjusting plate to make it within specification.

Available driven plates	
Part No.	Thickness mm (in)
31589AA041	1.6 (0.063)
31589AA050	2.0 (0.079)
31589AA060	2.4 (0.094)
31589AA070	2.8 (0.110)

# MULTI-PLATE CLUTCH

Automatic Transmission

## 10. Multi-plate Clutch S510589

### A: REMOVAL S510589A18

The multi-plate clutch is removed in the same way that the extension case is removed. <Ref. to AT-36, REMOVAL, Extension Case.>

### B: INSTALLATION S510589A11

The multi-plate clutch is installed in the same way that the extension case is installed. <Ref. to AT-36, INSTALLATION, Extension Case.>

### C: INSPECTION S510589A10

- Check the drive plate facing for wear and damage.
- Check the snap ring for wear, return spring for permanent set and breakage, and return spring for deformation.
- Check the lathe cut ring for damage.
- Measure the clearance of the multi-plate clutch and adjust it to within specifications. <Ref. to AT-46, ADJUSTMENT, Multi-plate Clutch.>

### D: ADJUSTMENT S510589A01

- 1) Remove the drive plate and driven plate from the center differential carrier.
- 2) Measure the distance "L" from mating surface of extension case to multi-plate clutch (LSD) piston with ST.

ST 398643600 GAUGE

L = Measured value - 15 mm  
(L = Measured value - 0.59 in)

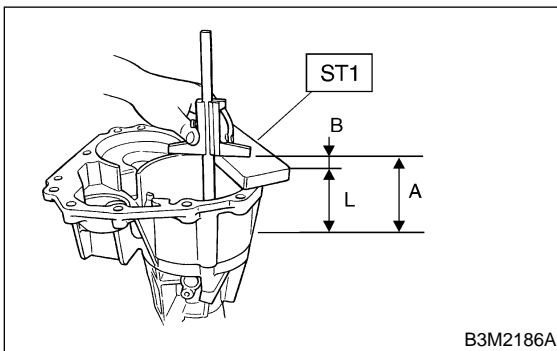

- A: Measured value  
B: ST thickness [15 mm (0.59 in)]  
L: Distance from end of extension case to end of rear drive shaft

- 3) Measure the height "ℓ" from mating surface of the transmission case to end surface of the center differential clutch drum with ST.  
ST 398744300 GAUGE  
ℓ = Measured value - 50 mm  
(ℓ = Measured value - 1.97 in)

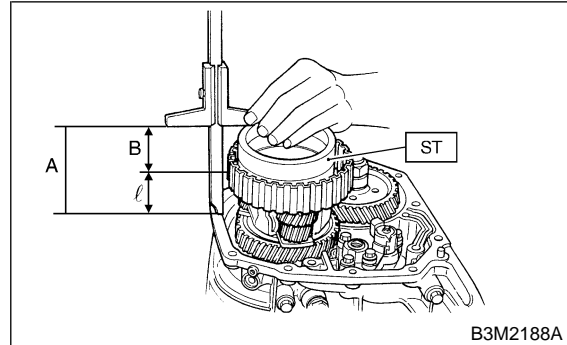

- A: Measured value  
B: ST thickness [50 mm (1.97 in)]  
ℓ: Distance from mating surface of transmission case to multi-plate clutch (LSD) piston

- 4) Calculation equation:

$$T = (L + 0.45 \text{ mm}) - \ell$$

$$[T = (L + 0.0177 \text{ in}) - \ell]$$

T: Measurements between end surface of clutch drum and multi-plate clutch (LSD) piston.

L: Distance from mating surface of extension case to multi-plate clutch (LSD) piston.

0.45: Gasket thickness

ℓ: Distance from mating surface of transmission case to end surface of the center differential clutch drum.

#### NOTE:

Measure thickness of driven and drive plates of multi-plate clutch (LSD) and determine clearance between measured value and "T".

#### Standard value:

**0.2 — 0.6 mm (0.008 — 0.024 in)**

#### Allowable limit:

**1.6 mm (0.063 in)**

If out of specification, replace plate set (drive and driven plate) and select a multi-plate clutch (LSD) piston side adjusting plate to make it within specification.

Available driven plates	
Part No.	Thickness mm (in)
31589AA041	1.6 (0.063)
31589AA050	2.0 (0.079)
31589AA060	2.4 (0.094)
31589AA070	2.8 (0.110)

## 11. Rear Drive Shaft S510156

### A: REMOVAL S510156A18

- 1) Remove rear vehicle speed sensor and separate the extension case from the transmission case. <Ref. to AT-36, REMOVAL, Extension Case.>
- 2) Extract the rear drive shaft from the center differential assembly.

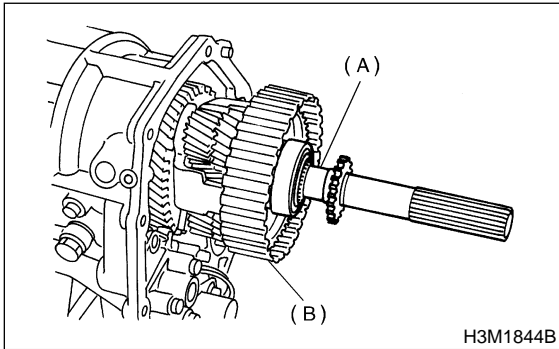

- (A) Rear drive shaft  
(B) Center differential carrier

- 3) Remove the drive plate and driven plate.

### B: INSTALLATION S510156A11

- 1) Install the drive plate and driven plate.
- 2) Insert the rear drive shaft into the center differential assembly.
- 3) Combine the transmission case with the extension case, and install the rear vehicle speed sensor. <Ref. to AT-36, INSTALLATION, Extension Case.>

### C: DISASSEMBLY S510156A06

- 1) Using a press, remove the revolution gear.

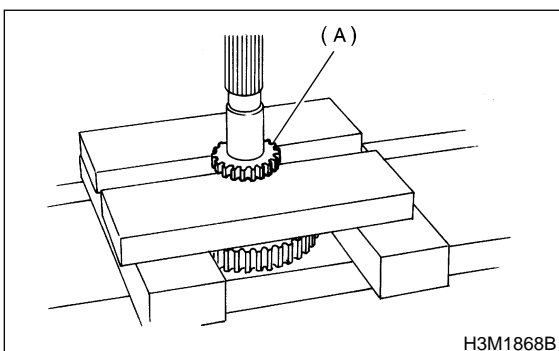

- (A) Revolution gear

- 2) Using a press, remove the front and rear side ball bearings and clutch hub.

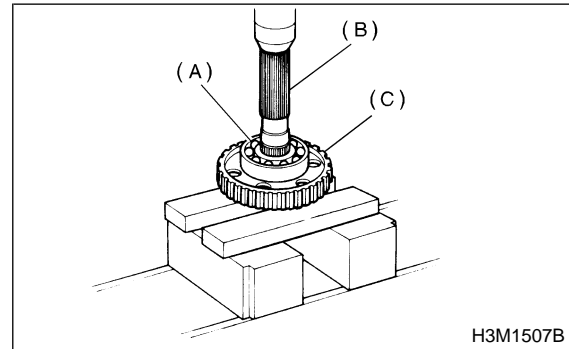

- (A) Rear ball bearing  
(B) Rear drive shaft  
(C) Clutch hub

### D: ASSEMBLY S510156A02

Assembly is in the reverse order of disassembly.

#### NOTE:

- Be sure to use a new ball bearings and revolution gear.
- Pay attention to the direction of the clutch hub.

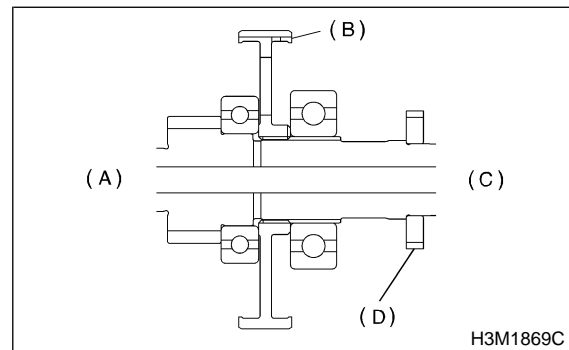

- (A) Front side  
(B) Clutch hub  
(C) Rear side  
(D) Revolution gear

### E: INSPECTION S510156A10

- Make sure that each component is free of harmful gouges, cuts, or dust.
- Measure the extension end play and adjust to within specifications. <Ref. to AT-44, WITH VTD, ADJUSTMENT, Transfer Clutch.>

## 11. Rear Drive Shaft S510156

### A: REMOVAL S510156A18

- 1) Remove rear vehicle speed sensor and separate the extension case from the transmission case. <Ref. to AT-36, REMOVAL, Extension Case.>
- 2) Extract the rear drive shaft from the center differential assembly.

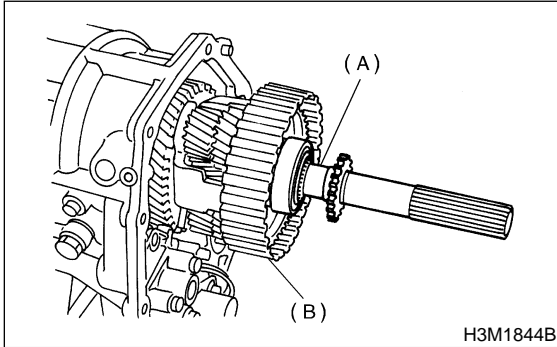

- (A) Rear drive shaft  
(B) Center differential carrier

- 3) Remove the drive plate and driven plate.

### B: INSTALLATION S510156A11

- 1) Install the drive plate and driven plate.
- 2) Insert the rear drive shaft into the center differential assembly.
- 3) Combine the transmission case with the extension case, and install the rear vehicle speed sensor. <Ref. to AT-36, INSTALLATION, Extension Case.>

### C: DISASSEMBLY S510156A06

- 1) Using a press, remove the revolution gear.

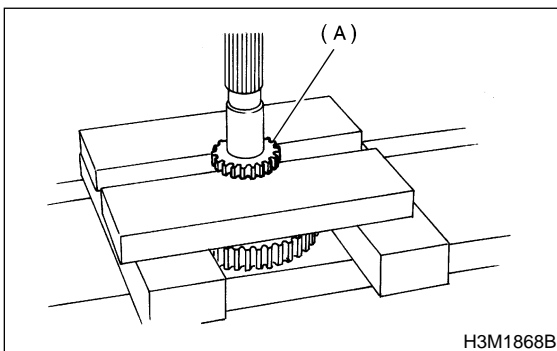

- (A) Revolution gear

- 2) Using a press, remove the front and rear side ball bearings and clutch hub.

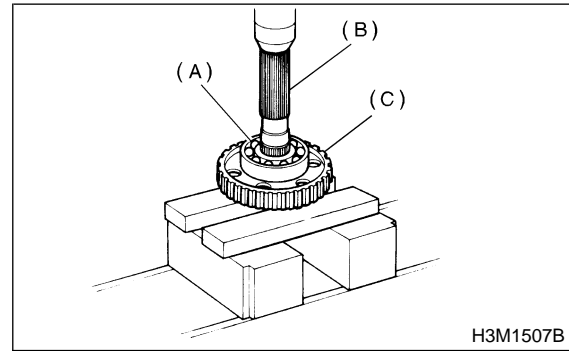

- (A) Rear ball bearing  
(B) Rear drive shaft  
(C) Clutch hub

### D: ASSEMBLY S510156A02

Assembly is in the reverse order of disassembly.

#### NOTE:

- Be sure to use a new ball bearings and revolution gear.
- Pay attention to the direction of the clutch hub.

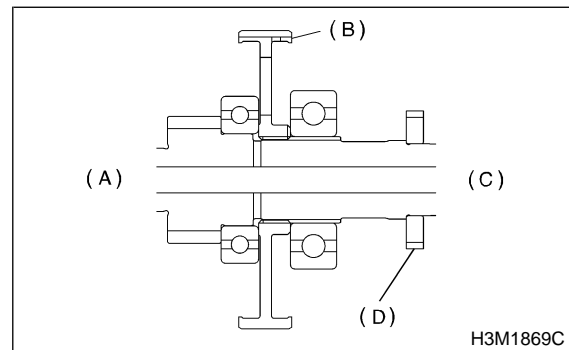

- (A) Front side  
(B) Clutch hub  
(C) Rear side  
(D) Revolution gear

### E: INSPECTION S510156A10

- Make sure that each component is free of harmful gouges, cuts, or dust.
- Measure the extension end play and adjust to within specifications. <Ref. to AT-44, WITH VTD, ADJUSTMENT, Transfer Clutch.>

# REDUCTION DRIVEN GEAR

Automatic Transmission

## 12. Reduction Driven Gear S510590

### A: REMOVAL S510590A18

#### 1. WITHOUT VTD S510590A1801

- 1) Remove rear vehicle speed sensor, and separate the transmission case and extension case. <Ref. to AT-36, REMOVAL, Extension Case.>
- 2) Straighten the staked portion, and remove the lock nut.

NOTE:

Set the range select lever to "P".

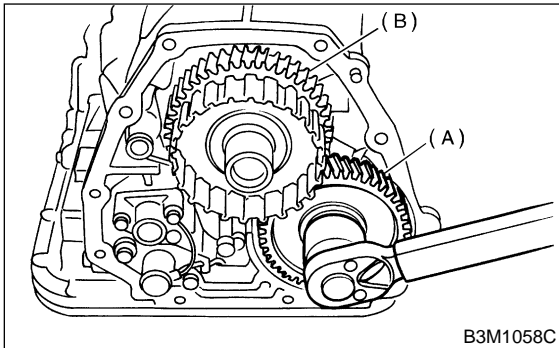

- (A) Reduction driven gear
- (B) Reduction drive gear

- 3) Using the ST1 and ST2, extract the reduction driven gear.

ST1 499737000 PULLER  
ST2 899524100 PULLER SET

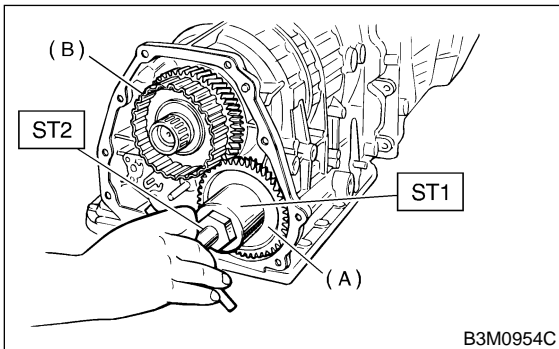

- (A) Reduction driven gear
- (B) Reduction drive gear

#### 2. WITH VTD S510590A1802

- 1) Remove the rear vehicle speed sensor, and separate the transmission case and extension case. <Ref. to AT-36, REMOVAL, Extension Case.>
- 2) Remove the rear drive shaft. <Ref. to AT-47, REMOVAL, Rear Drive Shaft.>

- 3) Straighten the staked portion, and remove the lock nut.

NOTE:

Set the range select lever to "P".

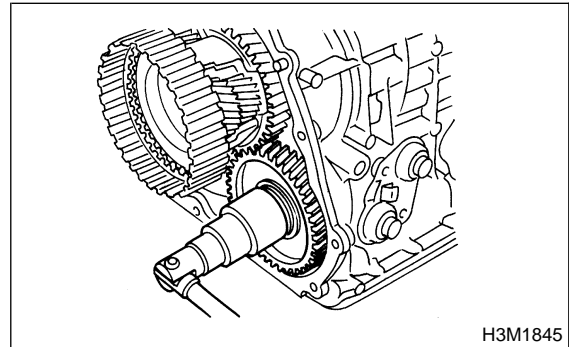

- 4) Using the ST1 and ST2, extract the reduction driven gear.

ST1 499737000 PULLER  
ST2 899524100 PULLER SET

- 5) Extract center differential assembly. <Ref. to AT-53, REMOVAL, Center Differential Carrier.>

### B: INSTALLATION S510590A11

#### 1. WITHOUT VTD S510590A1101

- 1) Using a plastic hammer, install reduction driven gear assembly and new washer, and tighten new drive pinion lock nut.

NOTE:

- Set the select lever in the "P" range.
- After tightening, stake the lock nut securely.

**Tightening torque:**

**100 N·m (10.2 kgf·m, 73.8 ft·lb)**

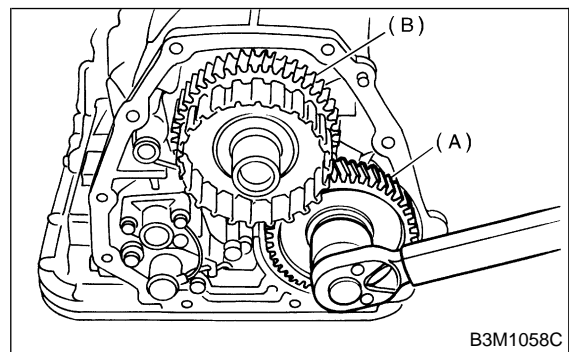

- (A) Reduction driven gear
- (B) Reduction drive gear

- 2) Combine the transmission case with the extension case, and install rear vehicle speed sensor. <Ref. to AT-36, INSTALLATION, Extension Case.>

## 2. WITH VTD S510590A1102

- 1) Using a plastic hammer, install reduction driven gear assembly.
- 2) Using a plastic hammer, install center differential.
- 3) Tighten drive pinion lock nut.

**NOTE:**

- Be sure to use a new lock nut and a washer.
- Set the range select lever in the "P" range.
- After tightening, stake the lock nut securely.

**Tightening torque:**

**100 N·m (10.2 kgf·m, 73.8 ft·lb)**

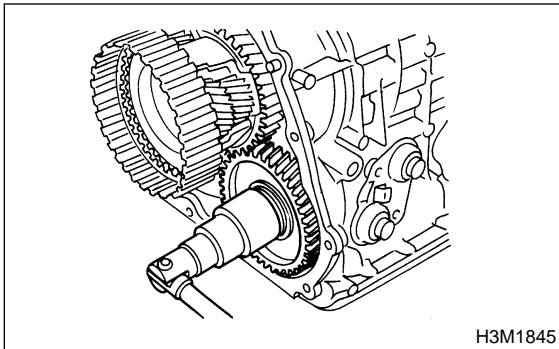

- 4) Insert the rear drive shaft assembly. <Ref. to AT-47, INSTALLATION, Rear Drive Shaft.>
- 5) Combine the transmission case with the extension case, and install rear vehicle speed sensor. <Ref. to AT-36, INSTALLATION, Extension Case.>

## C: DISASSEMBLY S510590A06

- 1) Remove snap ring from reduction driven gear.

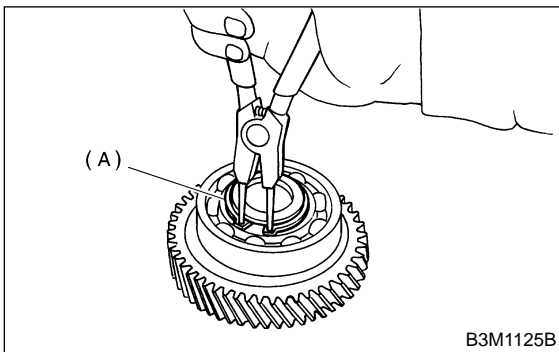

(A) Snap ring

- 2) Using ST, remove ball bearing from reduction driven gear.

ST 498077600 REMOVER

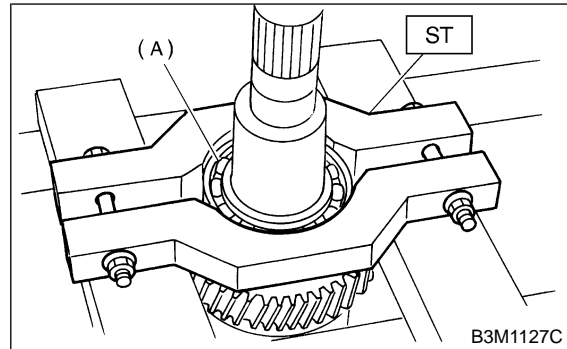

(A) Ball bearing

- 3) Remove snap rings from reduction driven gear. (Legacy 2.5 L US model and 3.0 L model)

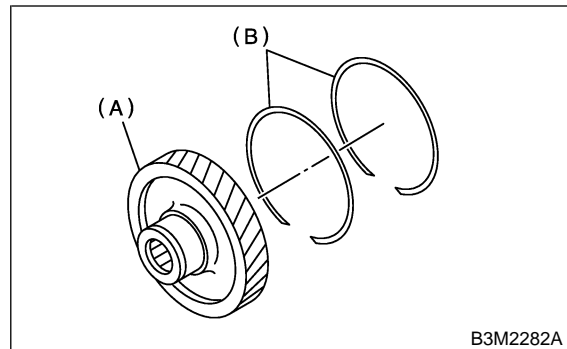

(A) Reduction driven gear  
(B) Snap ring

## D: ASSEMBLY S510590A02

- 1) Install snap rings to reduction driven gear. (Legacy 2.5 L US model and 3.0 L model)

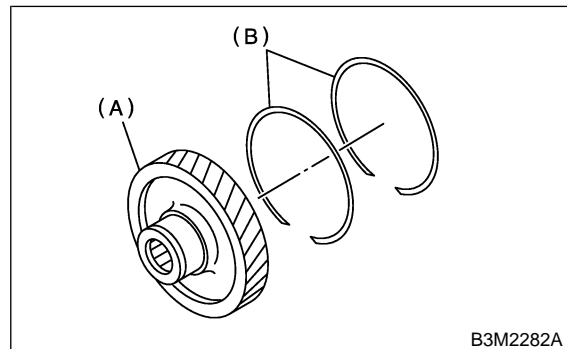

(A) Reduction driven gear  
(B) Snap ring

# REDUCTION DRIVEN GEAR

Automatic Transmission

---

2) Using a press, install ball bearing to reduction driven gear.

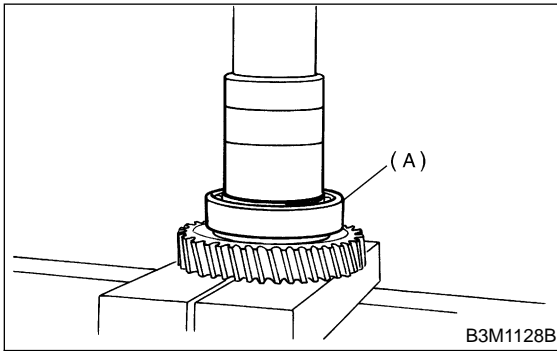

(A) Ball bearing

3) Install snap ring to reduction driven gear.

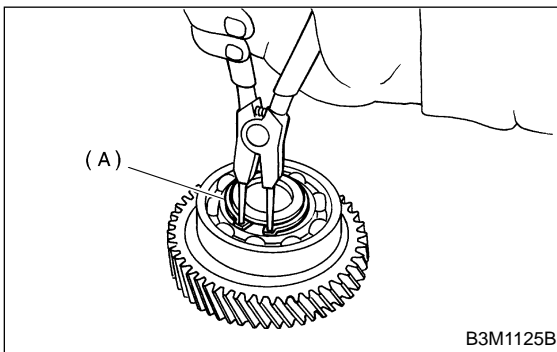

(A) Snap ring

## E: INSPECTION S510590A10

Check ball bearing and gear for dents or damage.

# REDUCTION DRIVEN GEAR

Automatic Transmission

## 12. Reduction Driven Gear S510590

### A: REMOVAL S510590A18

#### 1. WITHOUT VTD S510590A1801

- 1) Remove rear vehicle speed sensor, and separate the transmission case and extension case. <Ref. to AT-36, REMOVAL, Extension Case.>
- 2) Straighten the staked portion, and remove the lock nut.

NOTE:

Set the range select lever to "P".

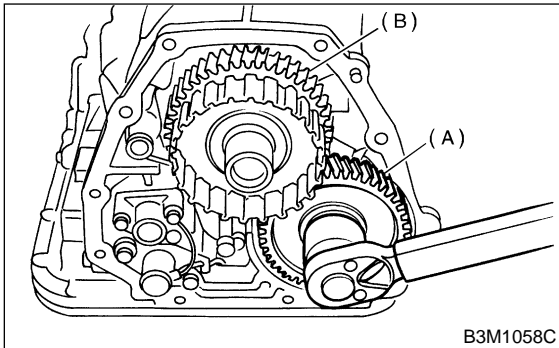

- (A) Reduction driven gear  
(B) Reduction drive gear

- 3) Using the ST1 and ST2, extract the reduction driven gear.

ST1 499737000 PULLER  
ST2 899524100 PULLER SET

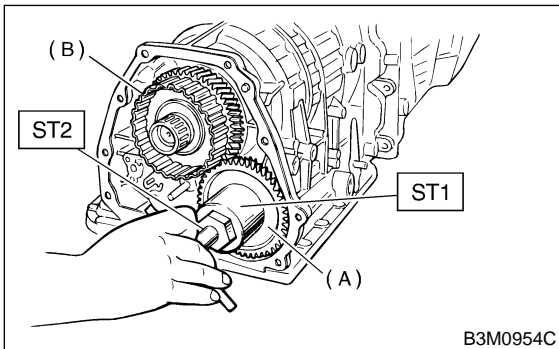

- (A) Reduction driven gear  
(B) Reduction drive gear

#### 2. WITH VTD S510590A1802

- 1) Remove the rear vehicle speed sensor, and separate the transmission case and extension case. <Ref. to AT-36, REMOVAL, Extension Case.>
- 2) Remove the rear drive shaft. <Ref. to AT-47, REMOVAL, Rear Drive Shaft.>

- 3) Straighten the staked portion, and remove the lock nut.

NOTE:

Set the range select lever to "P".

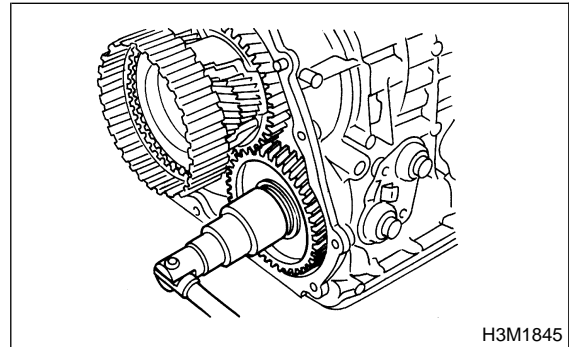

- 4) Using the ST1 and ST2, extract the reduction driven gear.

ST1 499737000 PULLER  
ST2 899524100 PULLER SET

- 5) Extract center differential assembly. <Ref. to AT-53, REMOVAL, Center Differential Carrier.>

### B: INSTALLATION S510590A11

#### 1. WITHOUT VTD S510590A1101

- 1) Using a plastic hammer, install reduction driven gear assembly and new washer, and tighten new drive pinion lock nut.

NOTE:

- Set the select lever in the "P" range.
- After tightening, stake the lock nut securely.

**Tightening torque:**

**100 N·m (10.2 kgf·m, 73.8 ft·lb)**

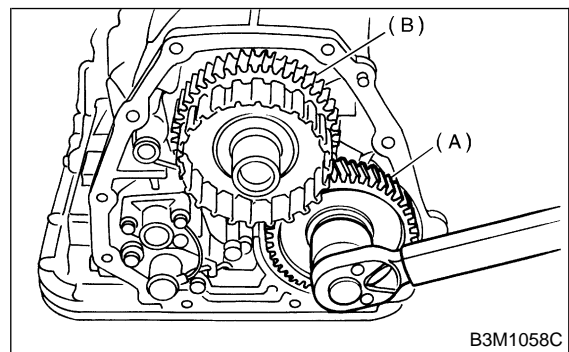

- (A) Reduction driven gear  
(B) Reduction drive gear

- 2) Combine the transmission case with the extension case, and install rear vehicle speed sensor. <Ref. to AT-36, INSTALLATION, Extension Case.>



## 2. WITH VTD S510590A1102

- 1) Using a plastic hammer, install reduction driven gear assembly.
- 2) Using a plastic hammer, install center differential.
- 3) Tighten drive pinion lock nut.

**NOTE:**

- Be sure to use a new lock nut and a washer.
- Set the range select lever in the "P" range.
- After tightening, stake the lock nut securely.

**Tightening torque:**

**100 N·m (10.2 kgf·m, 73.8 ft·lb)**

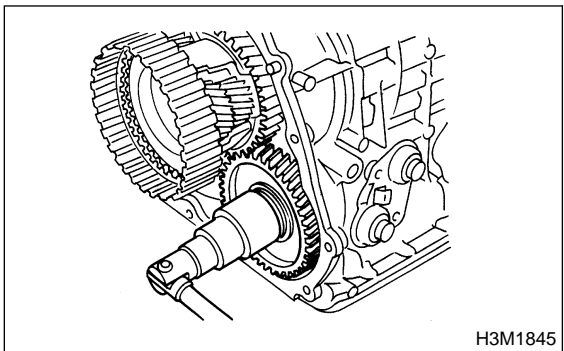

H3M1845

- 4) Insert the rear drive shaft assembly. <Ref. to AT-47, INSTALLATION, Rear Drive Shaft.>
- 5) Combine the transmission case with the extension case, and install rear vehicle speed sensor. <Ref. to AT-36, INSTALLATION, Extension Case.>

## C: DISASSEMBLY S510590A06

- 1) Remove snap ring from reduction driven gear.

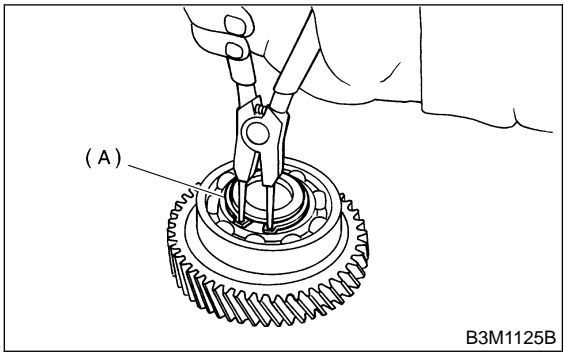

B3M1125B

(A) Snap ring

- 2) Using ST, remove ball bearing from reduction driven gear.

ST 498077600 REMOVER

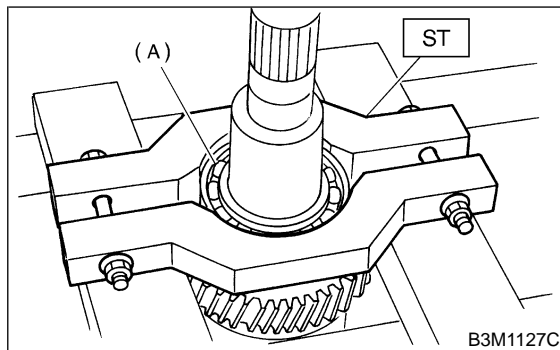

B3M1127C

(A) Ball bearing

- 3) Remove snap rings from reduction driven gear. (Legacy 2.5 L US model and 3.0 L model)

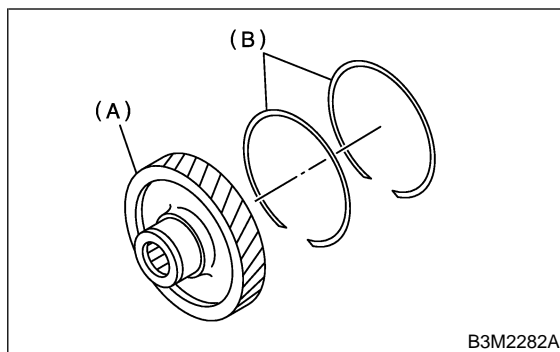

B3M2282A

(A) Reduction driven gear  
(B) Snap ring

## D: ASSEMBLY S510590A02

- 1) Install snap rings to reduction driven gear. (Legacy 2.5 L US model and 3.0 L model)

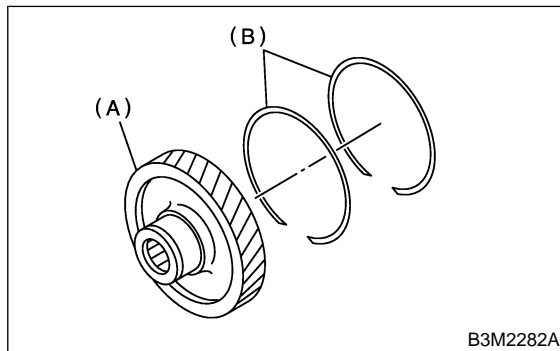

B3M2282A

(A) Reduction driven gear  
(B) Snap ring

# REDUCTION DRIVEN GEAR

Automatic Transmission

---

2) Using a press, install ball bearing to reduction driven gear.

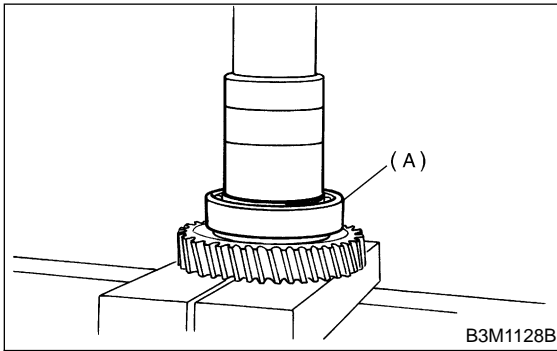

(A) Ball bearing

3) Install snap ring to reduction driven gear.

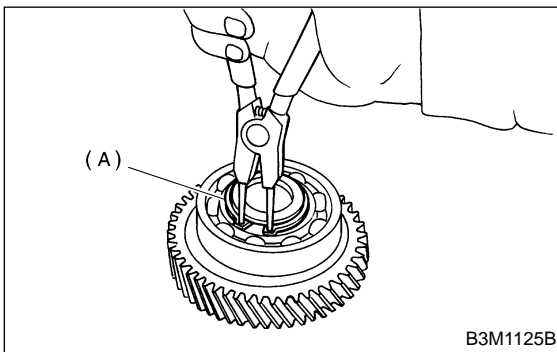

(A) Snap ring

## E: INSPECTION S510590A10

Check ball bearing and gear for dents or damage.

## 13. Reduction Drive Gear S510591

### A: REMOVAL S510591A18

- 1) Remove rear vehicle speed sensor, and separate the transmission case and extension case. <Ref. to AT-36, REMOVAL, Extension Case.>
- 2) Remove the reduction driven gear. <Ref. to AT-48, WITHOUT VTD, REMOVAL, Reduction Driven Gear.>
- 3) Using ST, extract the reduction drive gear.  
ST1 499737100 PULLER  
ST2 899524100 PULLER SET

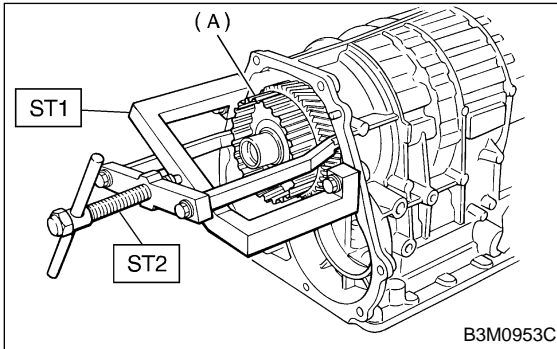

(A) Reduction drive gear

### B: INSTALLATION S510591A11

- 1) Install the reduction drive gear assembly.

**NOTE:**  
Insert it fully into position until the bearing shoulder bottoms.

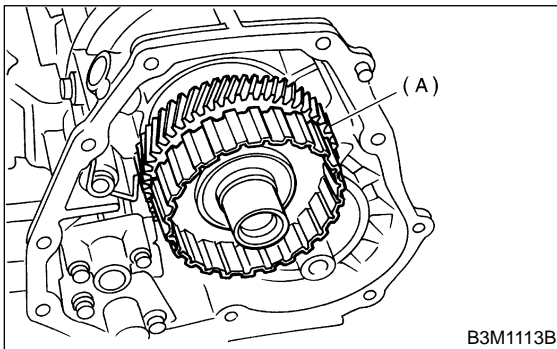

(A) Reduction drive gear

- 2) Install the reduction driven gear. <Ref. to AT-48, WITHOUT VTD, INSTALLATION, Reduction Drive Gear.>
- 3) Combine the transmission case with the extension case, and install rear vehicle speed sensor. <Ref. to AT-36, INSTALLATION, Extension Case.>

### C: DISASSEMBLY S510591A06

- 1) Take out the seal rings.

**NOTE:**  
Be careful not to damage the seal rings.

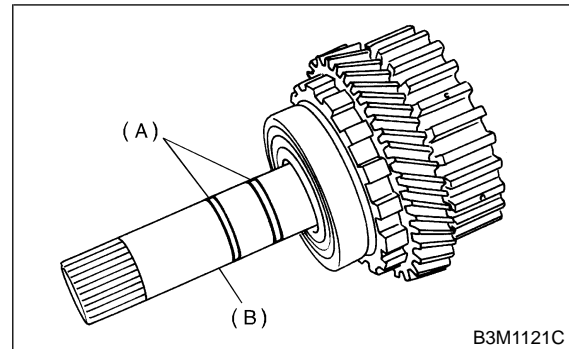

(A) Seal rings  
(B) Reduction drive shaft

- 2) Using ST, remove the ball bearing.  
ST 498077600 REMOVER

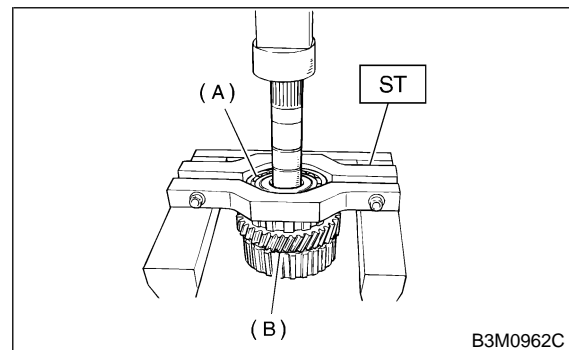

(A) Ball bearing  
(B) Reduction drive gear

- 3) Using a press, remove the reduction drive gear.

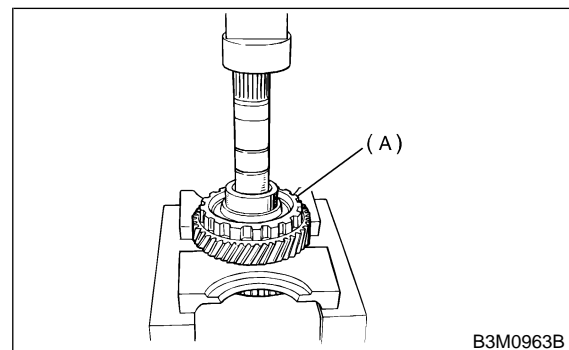

(A) Reduction drive gear

### D: ASSEMBLY S510591A02

- 1) Press-fit the reduction drive gear to the shaft.
- 2) Press-fit the ball bearing to the reduction drive gear.
- 3) Attach new seal rings.

# REDUCTION DRIVE GEAR

Automatic Transmission

---

## NOTE:

To make subsequent assembly easier, apply vaseline to the grooves of the shaft and to the exterior of the seal ring.

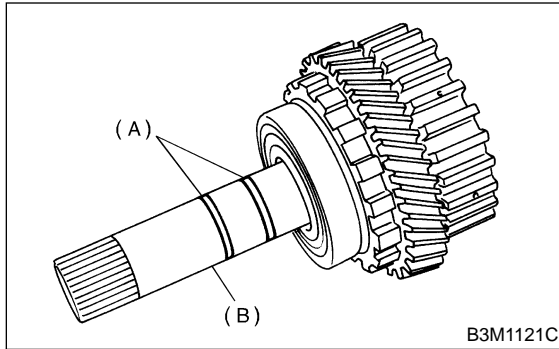

- (A) Seal rings
- (B) Reduction drive shaft

## E: INSPECTION S510591A10

- Rotate bearing by hand, make sure it rotates smoothly.
- Make sure that each component is free of harmful gouges, cuts, or dust.
- Measure the extension end play and adjust it to within specifications. <Ref. to AT-44, WITHOUT VTD, ADJUSTMENT, Transfer Clutch.>

## 13. Reduction Drive Gear S510591

### A: REMOVAL S510591A18

- 1) Remove rear vehicle speed sensor, and separate the transmission case and extension case. <Ref. to AT-36, REMOVAL, Extension Case.>
- 2) Remove the reduction driven gear. <Ref. to AT-48, WITHOUT VTD, REMOVAL, Reduction Driven Gear.>
- 3) Using ST, extract the reduction drive gear.  
ST1 499737100 PULLER  
ST2 899524100 PULLER SET

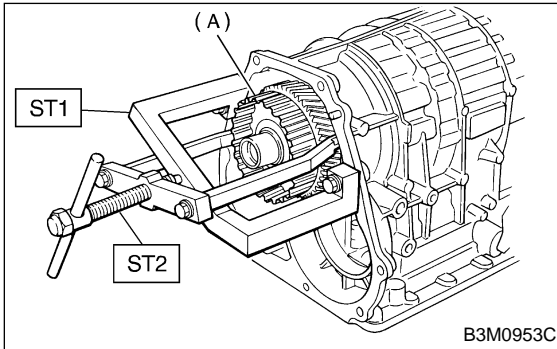

(A) Reduction drive gear

### B: INSTALLATION S510591A11

- 1) Install the reduction drive gear assembly.

**NOTE:**  
Insert it fully into position until the bearing shoulder bottoms.

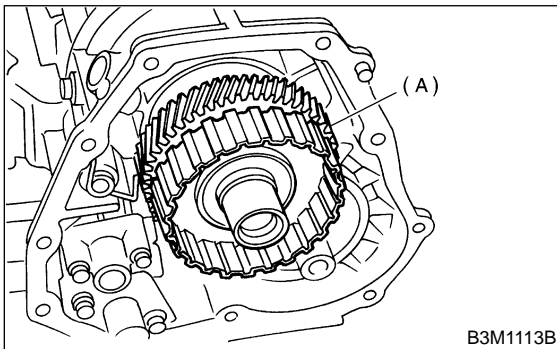

(A) Reduction drive gear

- 2) Install the reduction driven gear. <Ref. to AT-48, WITHOUT VTD, INSTALLATION, Reduction Drive Gear.>
- 3) Combine the transmission case with the extension case, and install rear vehicle speed sensor. <Ref. to AT-36, INSTALLATION, Extension Case.>

### C: DISASSEMBLY S510591A06

- 1) Take out the seal rings.

**NOTE:**  
Be careful not to damage the seal rings.

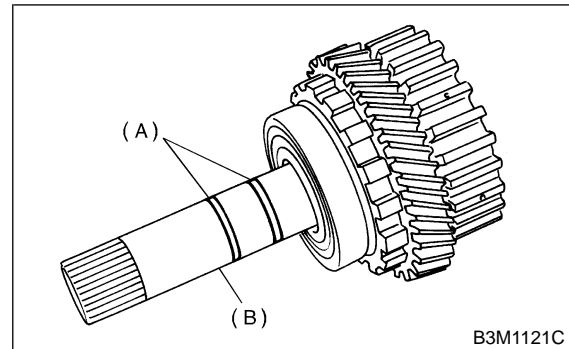

(A) Seal rings  
(B) Reduction drive shaft

- 2) Using ST, remove the ball bearing.  
ST 498077600 REMOVER

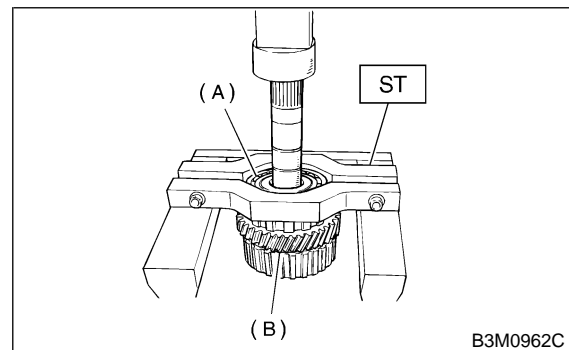

(A) Ball bearing  
(B) Reduction drive gear

- 3) Using a press, remove the reduction drive gear.

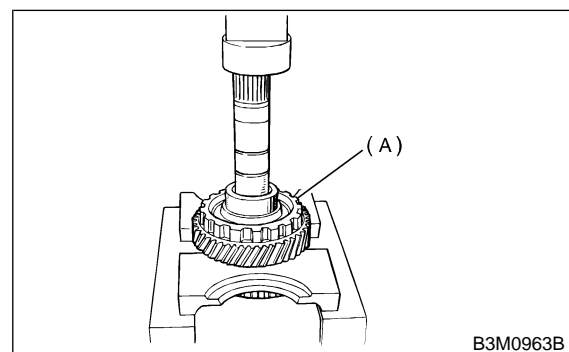

(A) Reduction drive gear

### D: ASSEMBLY S510591A02

- 1) Press-fit the reduction drive gear to the shaft.
- 2) Press-fit the ball bearing to the reduction drive gear.
- 3) Attach new seal rings.

# REDUCTION DRIVE GEAR

Automatic Transmission

---

## NOTE:

To make subsequent assembly easier, apply vaseline to the grooves of the shaft and to the exterior of the seal ring.

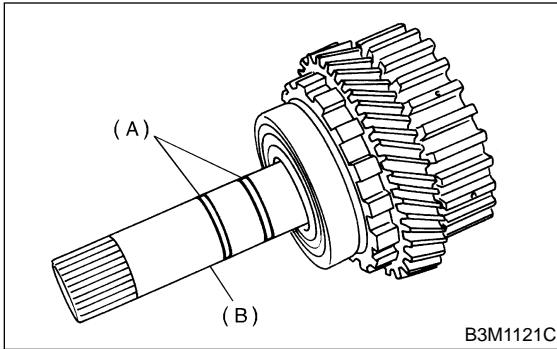

- (A) Seal rings
- (B) Reduction drive shaft

## E: INSPECTION S510591A10

- Rotate bearing by hand, make sure it rotates smoothly.
- Make sure that each component is free of harmful gouges, cuts, or dust.
- Measure the extension end play and adjust it to within specifications. <Ref. to AT-44, WITHOUT VTD, ADJUSTMENT, Transfer Clutch.>

## 14. Center Differential Carrier

S510592

### A: REMOVAL S510592A18

- 1) Remove rear vehicle speed sensor, and separate the extension case from the transmission case. <Ref. to AT-36, REMOVAL, Extension Case.>
- 2) Pull out the rear drive shaft. <Ref. to AT-47, REMOVAL, Rear Drive Shaft.>
- 3) Using ST, extract the center differential carrier assembly.

ST1 499737100 PULLER

ST2 899524100 PULLER SET

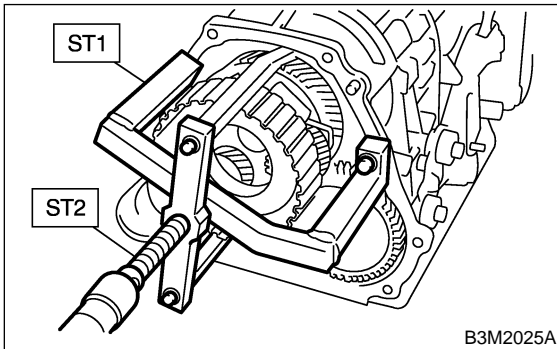

- 4) Extract shim from transmission case.

### B: INSTALLATION S510592A11

- 1) Install the center differential assembly with shim.

NOTE:

Insert it fully into position until the bearing shoulder bottoms.

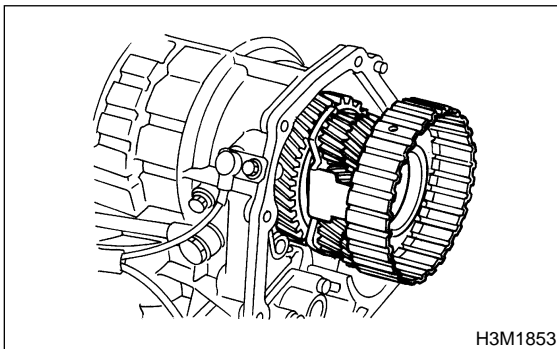

- 2) Insert the rear drive shaft. <Ref. to AT-47, INSTALLATION, Rear Drive Shaft.>
- 3) Combine the transmission case with the extension case, and install rear vehicle speed sensor. <Ref. to AT-36, INSTALLATION, Extension Case.>

### C: DISASSEMBLY S510592A06

- 1) Remove seal ring.

NOTE:

Do not re-use seal ring. Prepare a new one.

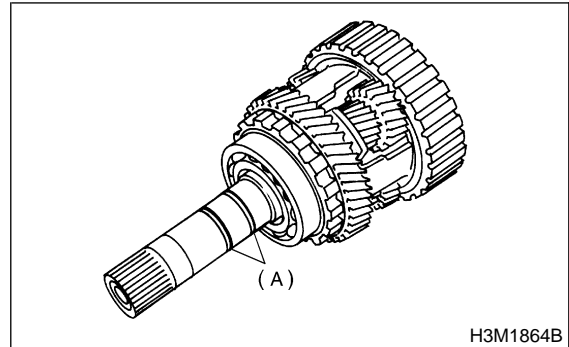

(A) Seal rings

- 2) Using a press and ST, remove the ball bearing. ST 498077600 REMOVER

NOTE:

Do not re-use wheel bearing. Prepare a new one.

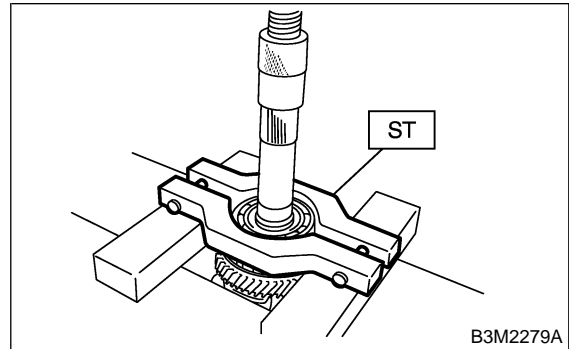

- 3) Remove snap ring, and pull out shafts from center differential assembly.

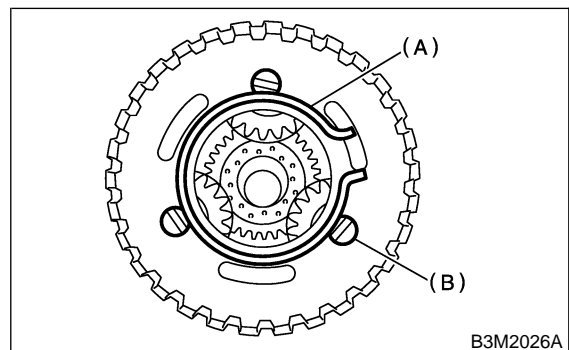

(A) Snap ring  
(B) Shaft

# CENTER DIFFERENTIAL CARRIER

Automatic Transmission

- 4) Remove thrust washer, pinion gears and washers from center differential assembly.

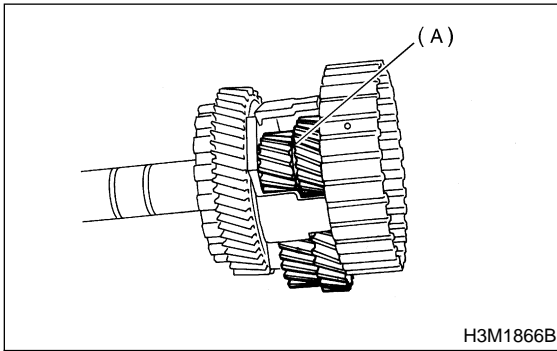

(A) Pinion gear

- 5) Pull out intermediate shaft and thrust bearing.

## D: ASSEMBLY S510592A02

- 1) Install thrust washer to intermediate shaft.
- 2) Install thrust bearing and intermediate shaft.
- 3) Install pinion gears and washers.
- 4) Put shaft in center differential assembly.
- 5) Install snap ring.
- 6) Using a press, press-fit the new ball bearing to center differential assembly.

ST 498077000 REMOVER

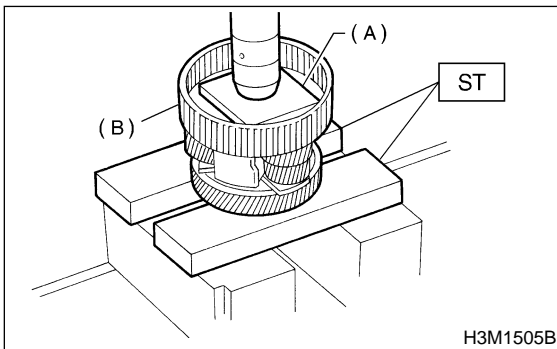

(A) Plate

(B) Center differential carrier

## E: INSPECTION S510592A10

- Make sure that each component is free of harmful gouges, cuts, or dust.
- Measure the extension end play and adjust it to within specifications. <Ref. to AT-44, WITH VTD, ADJUSTMENT, Transfer Clutch.>



## 14. Center Differential Carrier

S510592

### A: REMOVAL S510592A18

- 1) Remove rear vehicle speed sensor, and separate the extension case from the transmission case. <Ref. to AT-36, REMOVAL, Extension Case.>
- 2) Pull out the rear drive shaft. <Ref. to AT-47, REMOVAL, Rear Drive Shaft.>
- 3) Using ST, extract the center differential carrier assembly.

ST1 499737100 PULLER

ST2 899524100 PULLER SET

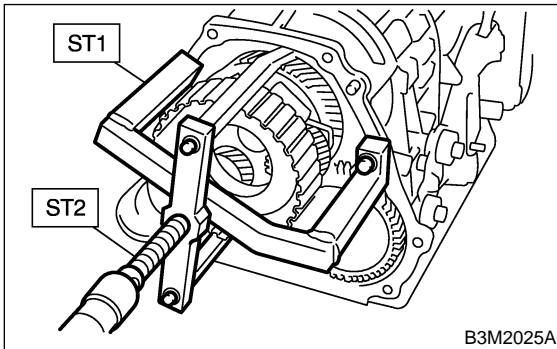

- 4) Extract shim from transmission case.

### B: INSTALLATION S510592A11

- 1) Install the center differential assembly with shim.

NOTE:

Insert it fully into position until the bearing shoulder bottoms.

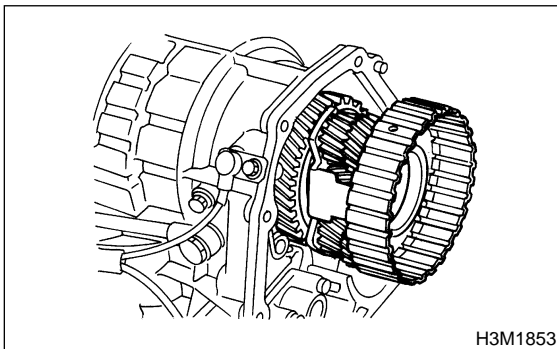

- 2) Insert the rear drive shaft. <Ref. to AT-47, INSTALLATION, Rear Drive Shaft.>
- 3) Combine the transmission case with the extension case, and install rear vehicle speed sensor. <Ref. to AT-36, INSTALLATION, Extension Case.>

### C: DISASSEMBLY S510592A06

- 1) Remove seal ring.

NOTE:

Do not re-use seal ring. Prepare a new one.

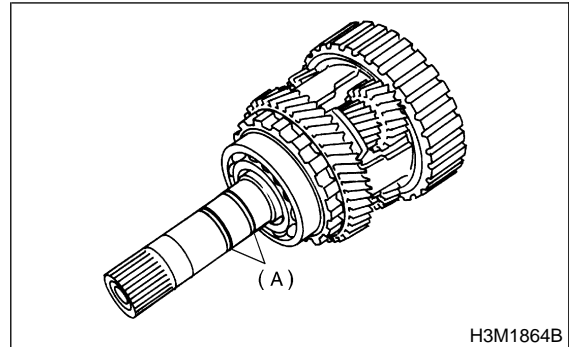

(A) Seal rings

- 2) Using a press and ST, remove the ball bearing. ST 498077600 REMOVER

NOTE:

Do not re-use wheel bearing. Prepare a new one.

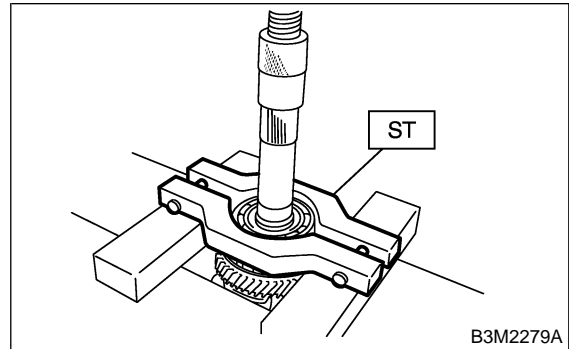

- 3) Remove snap ring, and pull out shafts from center differential assembly.

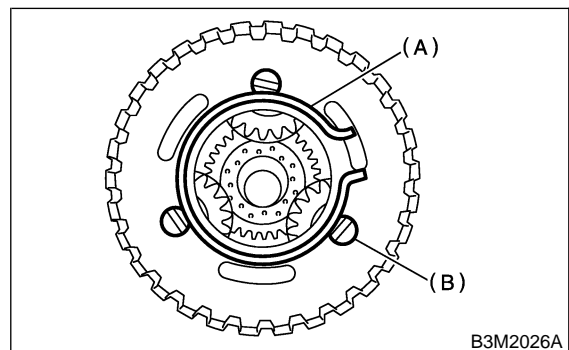

(A) Snap ring  
(B) Shaft

# CENTER DIFFERENTIAL CARRIER

Automatic Transmission

- 4) Remove thrust washer, pinion gears and washers from center differential assembly.

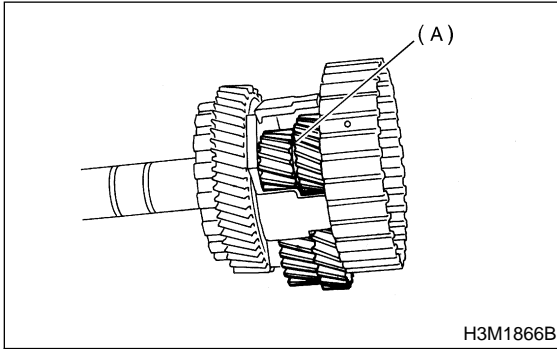

(A) Pinion gear

- 5) Pull out intermediate shaft and thrust bearing.

## D: ASSEMBLY S510592A02

- 1) Install thrust washer to intermediate shaft.
- 2) Install thrust bearing and intermediate shaft.
- 3) Install pinion gears and washers.
- 4) Put shaft in center differential assembly.
- 5) Install snap ring.
- 6) Using a press, press-fit the new ball bearing to center differential assembly.

ST 498077000 REMOVER

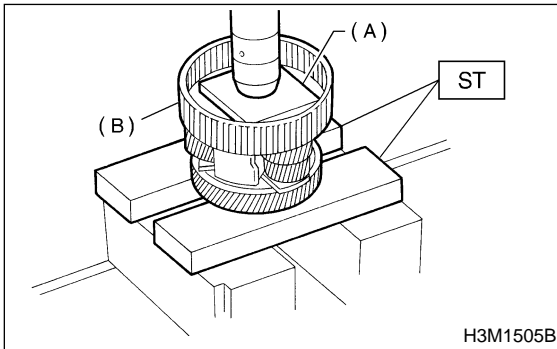

(A) Plate

(B) Center differential carrier

## E: INSPECTION S510592A10

- Make sure that each component is free of harmful gouges, cuts, or dust.
- Measure the extension end play and adjust it to within specifications. <Ref. to AT-44, WITH VTD, ADJUSTMENT, Transfer Clutch.>

## 15. Transfer Duty Solenoid and Valve Body

S510161

### A: REMOVAL

S510161A18

- 1) Remove rear vehicle speed sensor and separate transmission case and extension case sections. <Ref. to AT-36, REMOVAL, Extension Case.>
- 2) Disconnect connector from transfer duty solenoid.
- 3) Remove transfer valve body and transfer duty solenoid.

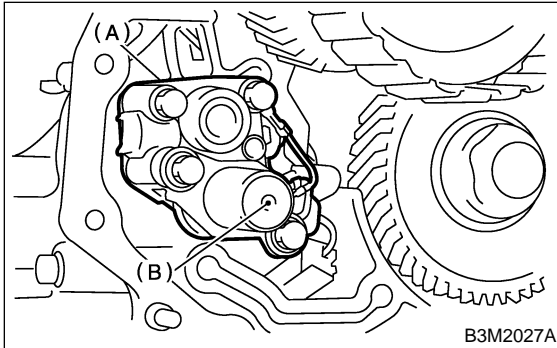

- (A) Transfer valve body  
(B) Transfer duty solenoid

- 4) Pull out inlet filter

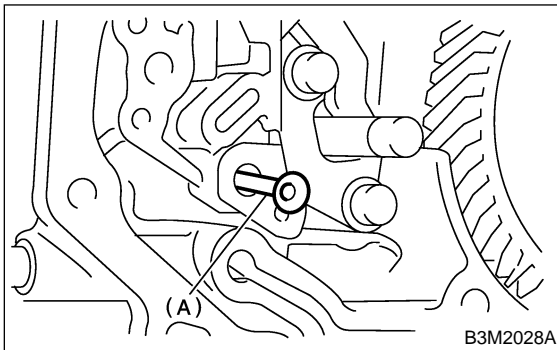

- (A) Inlet filter

- 5) Remove the oil seal from the transfer valve body.

### B: INSTALLATION

S510161A11

- 1) Insert the oil seal into the transfer valve body.
- 2) Install inlet filter to transmission case.

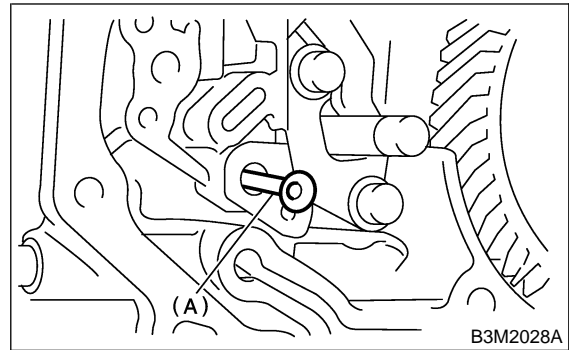

- (A) Inlet filter

- 3) Install transfer valve plate, valve body and transfer duty solenoid to transmission case.

#### NOTE:

- Be sure to install transfer seal lip to transfer control valve body.
- If transfer seal lip is damaged, replace seal with new one.

#### Tightening torque:

**8 N·m (0.8 kgf·m, 5.8 ft-lb)**

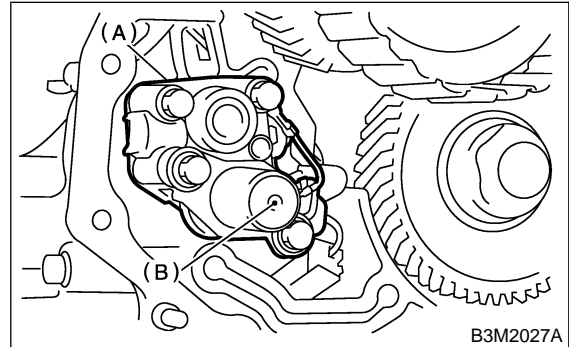

- (A) Transfer valve body  
(B) Transfer duty solenoid

- 4) Install the extension case from the transmission case. <Ref. to AT-36, INSTALLATION, Extension Case.>

# TRANSFER DUTY SOLENOID AND VALVE BODY

Automatic Transmission

5) Install the rear vehicle speed sensor.

**Tightening torque:**

**7 N·m (0.7 kgf-m, 5.1 ft-lb)**

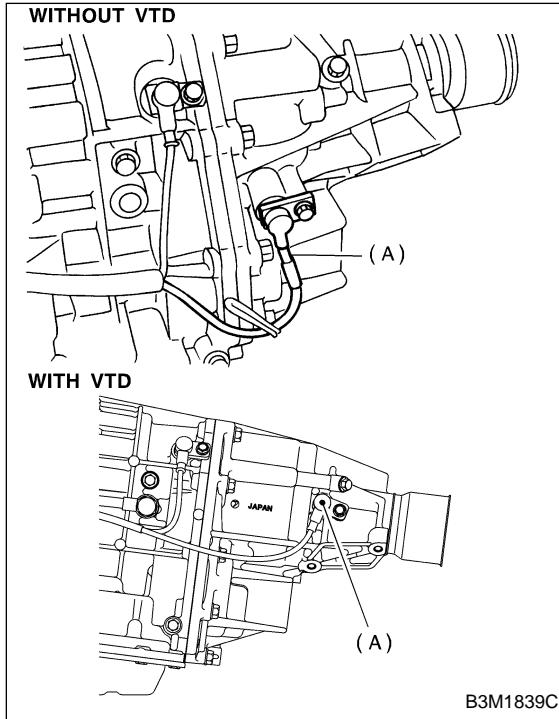

(A) Rear vehicle speed sensor

## C: INSPECTION S510161A10

Check each component for harmful cuts, damage and other faults.

## 15. Transfer Duty Solenoid and Valve Body

S510161

### A: REMOVAL

S510161A18

- 1) Remove rear vehicle speed sensor and separate transmission case and extension case sections. <Ref. to AT-36, REMOVAL, Extension Case.>
- 2) Disconnect connector from transfer duty solenoid.
- 3) Remove transfer valve body and transfer duty solenoid.

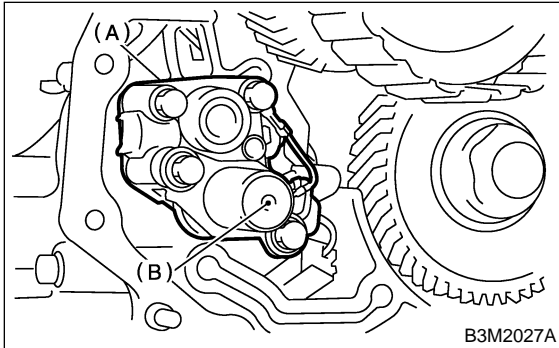

- (A) Transfer valve body  
(B) Transfer duty solenoid

- 4) Pull out inlet filter

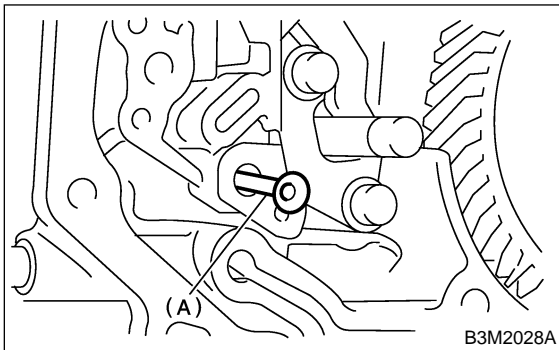

- (A) Inlet filter

- 5) Remove the oil seal from the transfer valve body.

### B: INSTALLATION

S510161A11

- 1) Insert the oil seal into the transfer valve body.
- 2) Install inlet filter to transmission case.

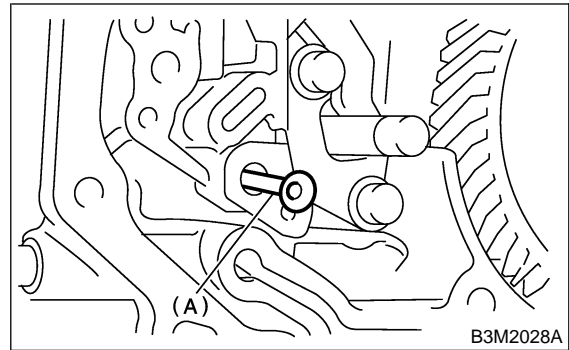

- (A) Inlet filter

- 3) Install transfer valve plate, valve body and transfer duty solenoid to transmission case.

#### NOTE:

- Be sure to install transfer seal lip to transfer control valve body.
- If transfer seal lip is damaged, replace seal with new one.

#### Tightening torque:

**8 N·m (0.8 kgf·m, 5.8 ft-lb)**

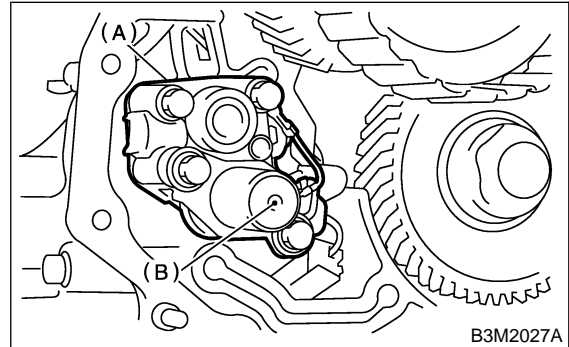

- (A) Transfer valve body  
(B) Transfer duty solenoid

- 4) Install the extension case from the transmission case. <Ref. to AT-36, INSTALLATION, Extension Case.>

# TRANSFER DUTY SOLENOID AND VALVE BODY

Automatic Transmission

5) Install the rear vehicle speed sensor.

**Tightening torque:**

**7 N·m (0.7 kgf-m, 5.1 ft-lb)**

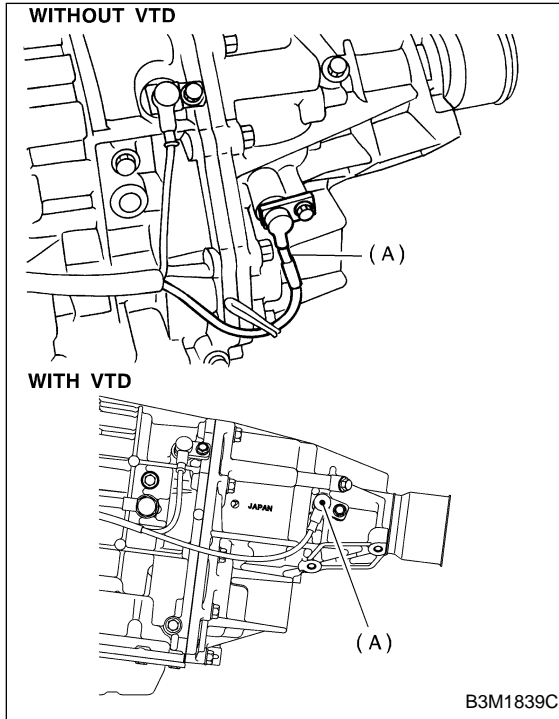

(A) Rear vehicle speed sensor

## C: INSPECTION S510161A10

Check each component for harmful cuts, damage and other faults.

## 16. Parking Pawl S510201

### A: REMOVAL S510201A18

1) Remove rear vehicle speed sensor and separate transmission case and extension case sections. <Ref. to AT-36, REMOVAL, Extension Case.>

2) For the model without VTD, remove the reduction drive gear. For the model with VTD, remove the center differential gear assembly.

Without VTD: <Ref. to AT-51, REMOVAL, Reduction Drive Gear.>

With VTD: <Ref. to AT-53, REMOVAL, Center Differential Carrier.>

3) Remove the parking pawl, return spring and shaft.

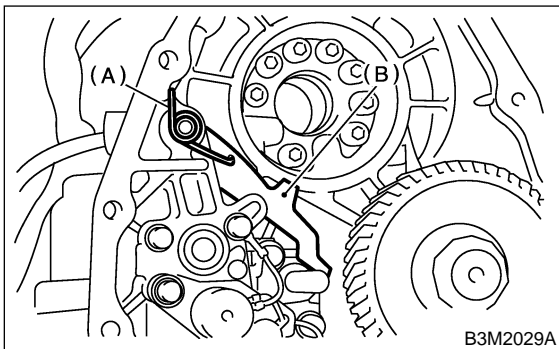

- (A) Return spring
- (B) Parking pawl

### B: INSTALLATION S510201A11

1) Install the parking pawl, shaft and return spring.

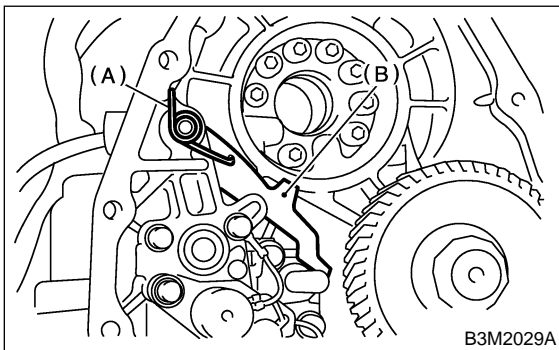

- (A) Return spring
- (B) Parking pawl

2) For the model without VTD, install the reduction drive gear. For the model with VTD, install the center differential gear assembly.

Without VTD: <Ref. to AT-51, INSTALLATION, Reduction Drive Gear.>

With VTD: <Ref. to AT-53, INSTALLATION, Center Differential Carrier.>

3) Install the extension case to the transmission case. <Ref. to AT-36, INSTALLATION, Extension Case.>

4) Install the rear vehicle speed sensor.

### Tightening torque:

**7 N·m (0.7 kgf-m, 5.1 ft-lb)**

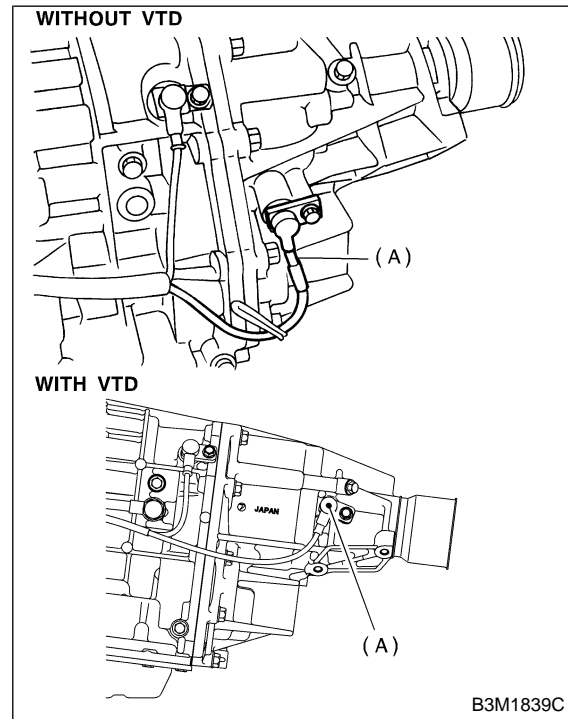

- (A) Rear vehicle speed sensor

### C: INSPECTION S510201A10

Make sure that the tab of the packing pole on the reduction gear is not worn or otherwise damaged.

## 16. Parking Pawl S510201

### A: REMOVAL S510201A18

1) Remove rear vehicle speed sensor and separate transmission case and extension case sections. <Ref. to AT-36, REMOVAL, Extension Case.>

2) For the model without VTD, remove the reduction drive gear. For the model with VTD, remove the center differential gear assembly.

Without VTD: <Ref. to AT-51, REMOVAL, Reduction Drive Gear.>

With VTD: <Ref. to AT-53, REMOVAL, Center Differential Carrier.>

3) Remove the parking pawl, return spring and shaft.

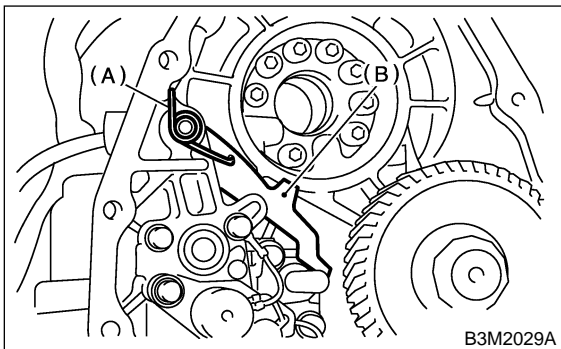

- (A) Return spring
- (B) Parking pawl

### B: INSTALLATION S510201A11

1) Install the parking pawl, shaft and return spring.

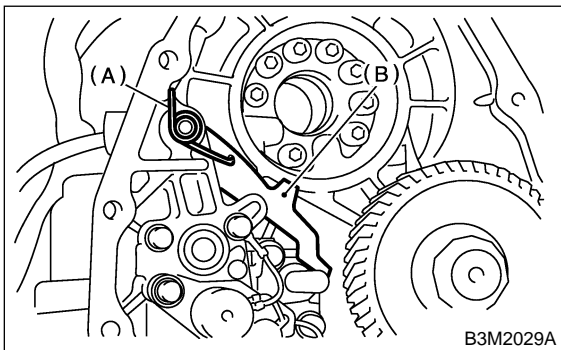

- (A) Return spring
- (B) Parking pawl

2) For the model without VTD, install the reduction drive gear. For the model with VTD, install the center differential gear assembly.

Without VTD: <Ref. to AT-51, INSTALLATION, Reduction Drive Gear.>

With VTD: <Ref. to AT-53, INSTALLATION, Center Differential Carrier.>

3) Install the extension case to the transmission case. <Ref. to AT-36, INSTALLATION, Extension Case.>

4) Install the rear vehicle speed sensor.

### Tightening torque:

**7 N·m (0.7 kgf-m, 5.1 ft-lb)**

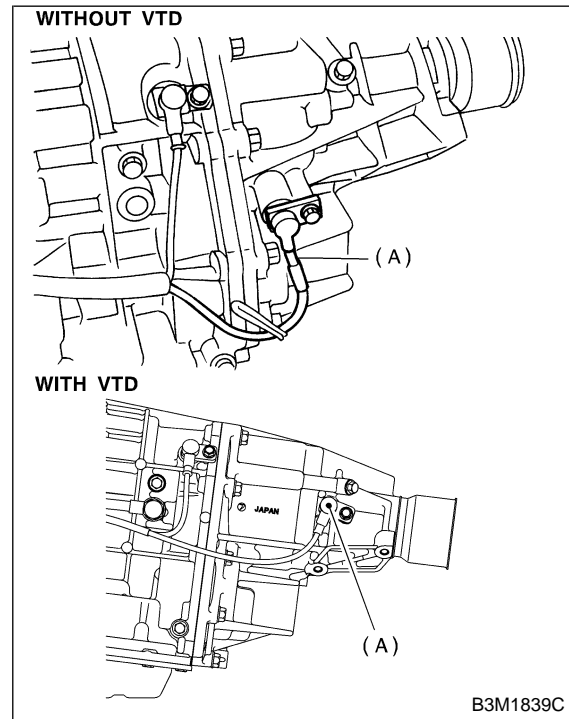

- (A) Rear vehicle speed sensor

### C: INSPECTION S510201A10

Make sure that the tab of the packing pole on the reduction gear is not worn or otherwise damaged.



# TORQUE CONVERTER CLUTCH CASE

Automatic Transmission

## 17. Torque Converter Clutch Case

S510206

### A: REMOVAL S510206A18

- 1) Extract the torque converter clutch assembly. <Ref. to AT-35, REMOVAL, Torque Converter Clutch Assembly.>
- 2) Remove the input shaft.

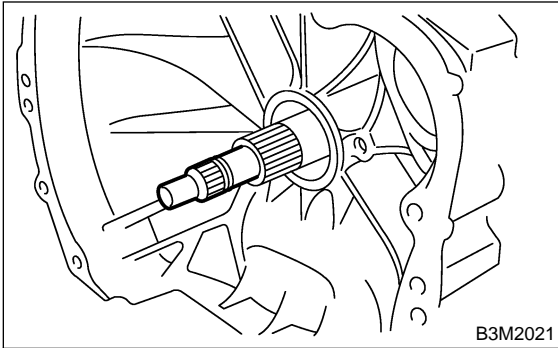

- 3) Remove air breather hose. <Ref. to AT-28, REMOVAL, Air Breather Hose.>
- 4) Remove pitching stopper bracket.

#### ● 3.0 L and TURBO models

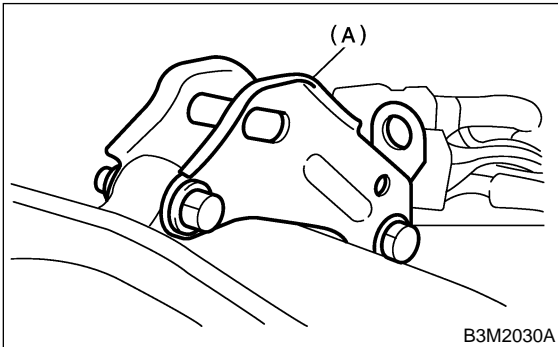

(A) Pitching stopper bracket

#### ● Except 3.0 L and TURBO models

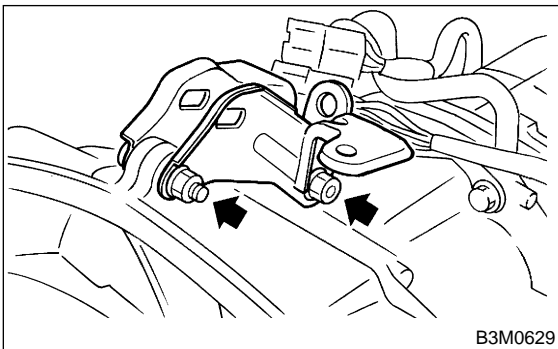

- 5) Disconnect transmission harness connector from stay.

#### NOTE:

Lift-up lever behind the connector and disconnect it from stay.

- 6) Disconnect inhibitor switch connector from stay.

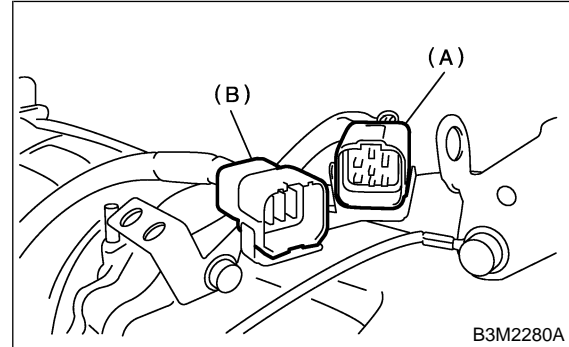

(A) Transmission harness  
(B) Inhibitor switch harness

- 7) Remove the oil charger pipe. <Ref. to AT-29, REMOVAL, Oil Charger Pipe.>

- 8) Remove the oil cooler inlet and outlet pipes. <Ref. to AT-30, REMOVAL, Oil Cooler Pipes.>

- 9) Separation of torque converter clutch case and transmission case sections

#### NOTE:

- Be careful not to damage the oil seal and bushing inside the torque converter clutch case by the oil pump cover.
- Be careful not to lose the rubber seal.

#### NOTE:

Separate these cases while tapping lightly on the housing.

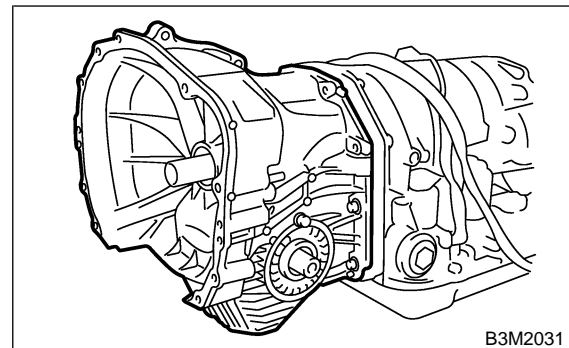

- 10) Wrap the axle shaft serration with vinyl tape.

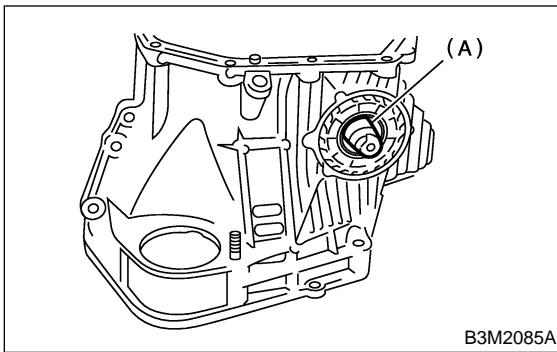

(A) Vinyl tape

11) Remove the seal pipe if it is attached. (Reusing is not allowed.)

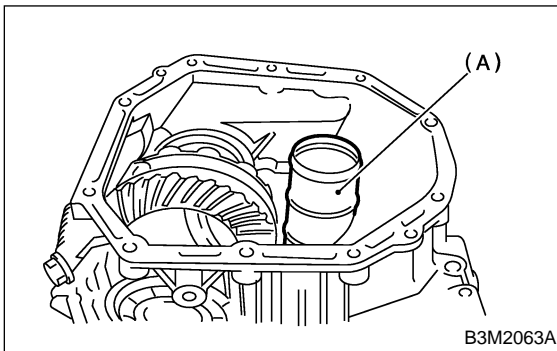

(A) Seal pipe

12) Remove the differential assembly. <Ref. to AT-74, REMOVAL, Front Differential.>  
 13) Remove the oil seal from torque converter clutch case.

## B: INSTALLATION SS10206A11

1) Check the appearance of each component and clean.

### NOTE:

Make sure each part is free of harmful cuts, damage and other faults.

2) Force-fit the oil seal to the torque converter clutch case with ST.

ST 398437700 DRIFT

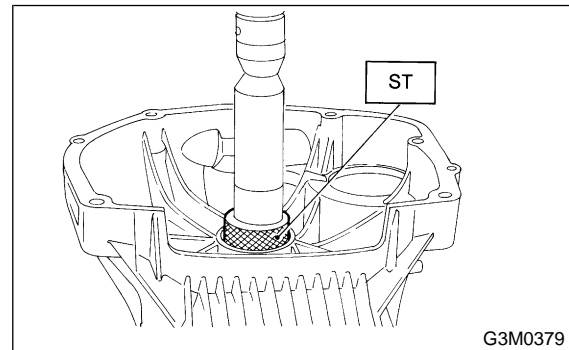

3) Install the differential assembly to the case. <Ref. to AT-74, INSTALLATION, Front Differential.>

4) Using ST, install the left and right side retainers. <Ref. to AT-78, ADJUSTMENT, Front Differential.>  
 ST 499787000 WRENCH ASSY

5) Install the new seal pipe to the torque converter clutch case.

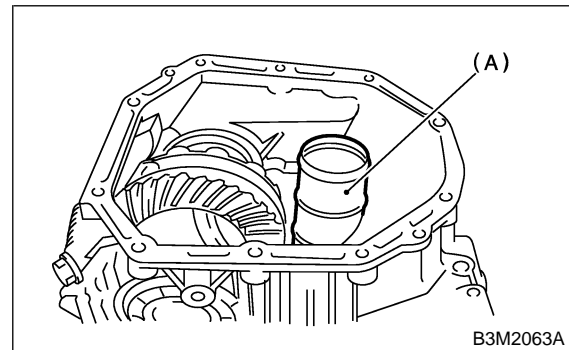

(A) Seal pipe

# TORQUE CONVERTER CLUTCH CASE

Automatic Transmission

6) Install the rubber seal to the torque converter clutch case.

**NOTE:**

Be careful not to lose the rubber seal.

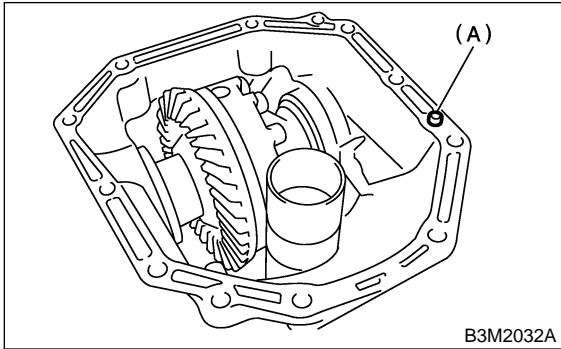

(A) Rubber seal

7) Apply proper amount of liquid gasket to the entire torque converter clutch case mating surface.

**Liquid gasket:**

**THREE BOND 1215**

**NOTE:**

Make sure that the rubber seal and seal pipe are fitted in position.

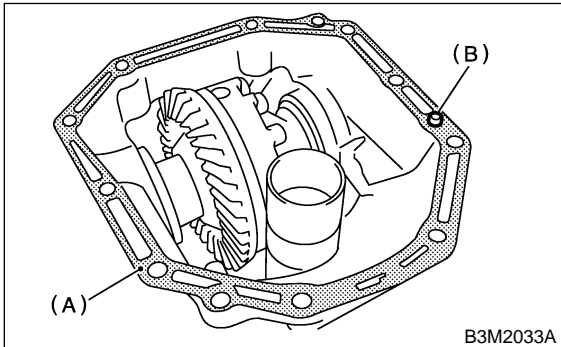

(A) THREE BOND (Part No. 1215)

(B) Rubber seal

8) Install the torque converter clutch case assembly to the transmission case assembly, and secure with six bolts and four nuts.

**NOTE:**

When installing, be careful not to damage the torque converter clutch case bushing and oil seal.

**Tightening torque:**

**41 N·m (4.2 kgf-m, 30.4 ft-lb)**

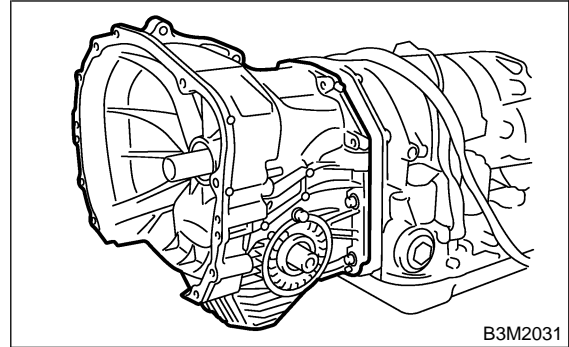

9) Install the pitching stopper bracket.

**Tightening torque:**

**41 N·m (4.2 kgf-m, 30.4 ft-lb)**

● **3.0 L and TURBO models**

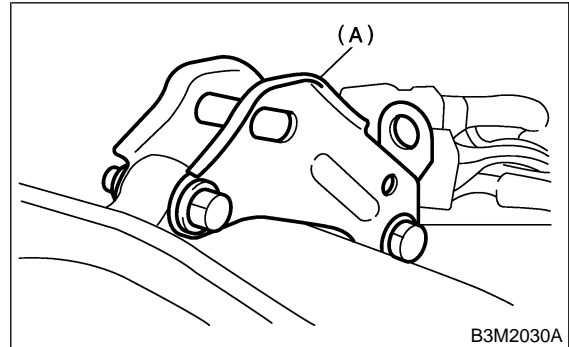

(A) Pitching stopper

● **Except 3.0 L and TURBO models**

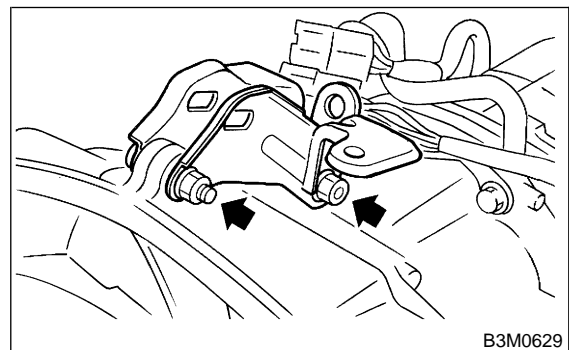

10) Insert inhibitor switch and transmission connector into stay.

11) Install air breather hose. <Ref. to AT-28, INSTALLATION, Air Breather Hose.>

- 12) Install the oil cooler pipes. <Ref. to AT-30, INSTALLATION, Oil Cooler Pipes.>
- 13) Install the oil charger pipe with O-ring. <Ref. to AT-29, INSTALLATION, Oil Charger Pipe.>
- 14) Insert the input shaft while turning lightly by hand.

**CAUTION:**

**Be careful not to damage the bushing.**

**Normal protrusion A:**

**50 — 55 mm (1.97 — 2.17 in)**

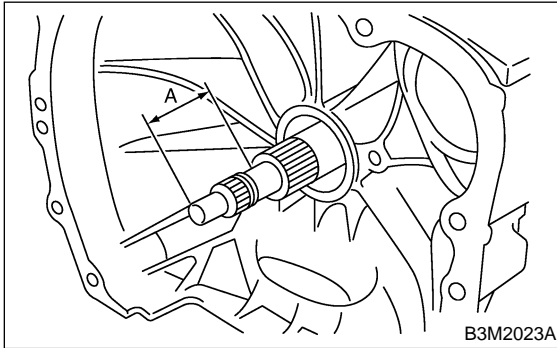

- 15) Install the torque converter clutch assembly. <Ref. to AT-35, INSTALLATION, Torque Converter Clutch Assembly.>

**C: INSPECTION**

S510206A10

Measure the backlash and adjust to within specifications. <Ref. to AT-71, ADJUSTMENT, Drive Pinion Shaft.>

# TORQUE CONVERTER CLUTCH CASE

Automatic Transmission

## 17. Torque Converter Clutch Case

S510206

### A: REMOVAL S510206A18

- 1) Extract the torque converter clutch assembly.  
<Ref. to AT-35, REMOVAL, Torque Converter Clutch Assembly.>
- 2) Remove the input shaft.

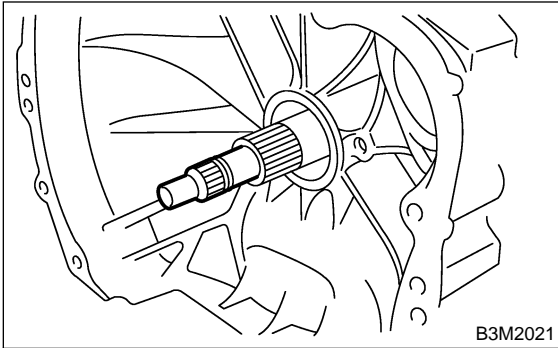

- 3) Remove air breather hose. <Ref. to AT-28, REMOVAL, Air Breather Hose.>
- 4) Remove pitching stopper bracket.

#### ● 3.0 L and TURBO models

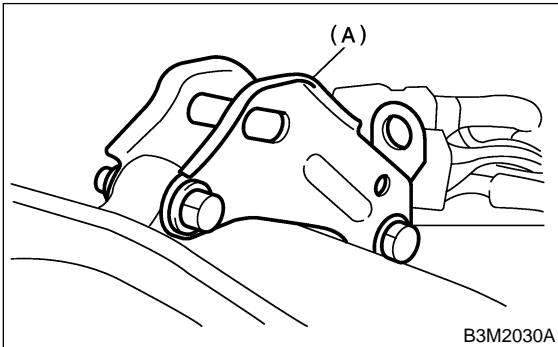

(A) Pitching stopper bracket

#### ● Except 3.0 L and TURBO models

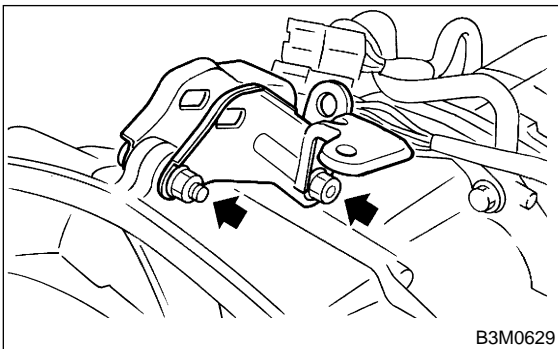

- 5) Disconnect transmission harness connector from stay.

#### NOTE:

Lift-up lever behind the connector and disconnect it from stay.

- 6) Disconnect inhibitor switch connector from stay.

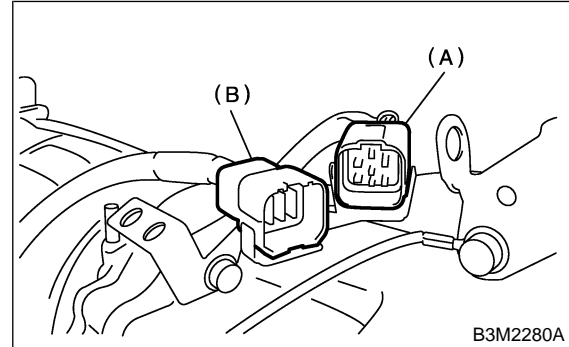

(A) Transmission harness  
(B) Inhibitor switch harness

- 7) Remove the oil charger pipe. <Ref. to AT-29, REMOVAL, Oil Charger Pipe.>
- 8) Remove the oil cooler inlet and outlet pipes. <Ref. to AT-30, REMOVAL, Oil Cooler Pipes.>
- 9) Separation of torque converter clutch case and transmission case sections

#### NOTE:

- Be careful not to damage the oil seal and bushing inside the torque converter clutch case by the oil pump cover.
- Be careful not to lose the rubber seal.

#### NOTE:

Separate these cases while tapping lightly on the housing.

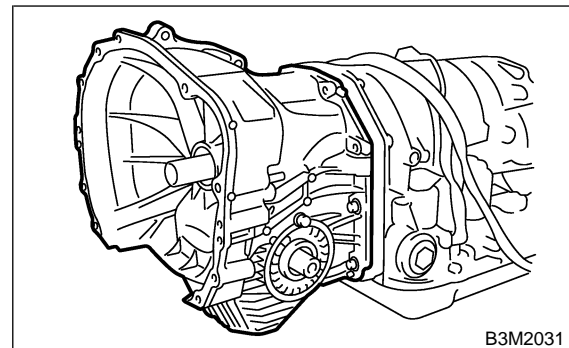

- 10) Wrap the axle shaft serration with vinyl tape.

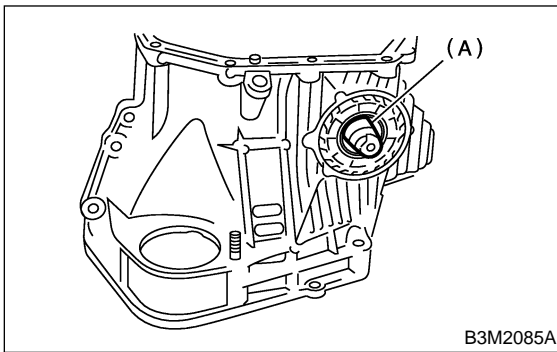

(A) Vinyl tape

11) Remove the seal pipe if it is attached. (Reusing is not allowed.)

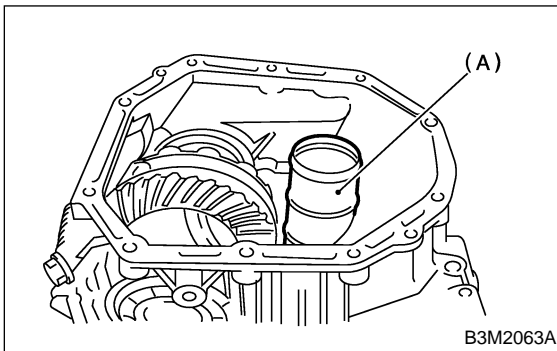

(A) Seal pipe

12) Remove the differential assembly. <Ref. to AT-74, REMOVAL, Front Differential.>  
 13) Remove the oil seal from torque converter clutch case.

## B: INSTALLATION S510206A11

1) Check the appearance of each component and clean.

### NOTE:

Make sure each part is free of harmful cuts, damage and other faults.

2) Force-fit the oil seal to the torque converter clutch case with ST.

ST 398437700 DRIFT

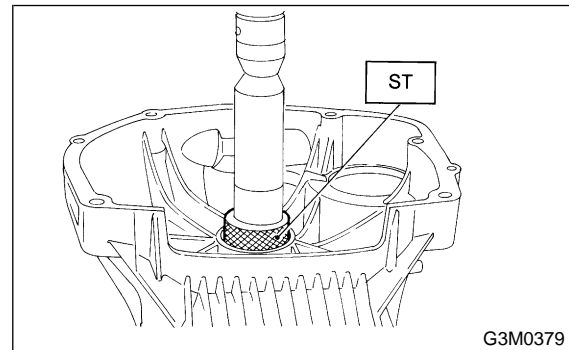

3) Install the differential assembly to the case. <Ref. to AT-74, INSTALLATION, Front Differential.>

4) Using ST, install the left and right side retainers. <Ref. to AT-78, ADJUSTMENT, Front Differential.>  
 ST 499787000 WRENCH ASSY

5) Install the new seal pipe to the torque converter clutch case.

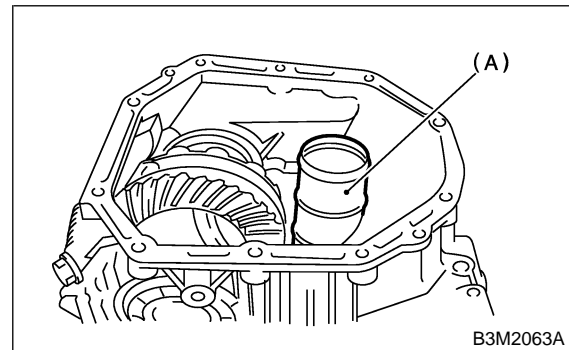

(A) Seal pipe

# TORQUE CONVERTER CLUTCH CASE

Automatic Transmission

6) Install the rubber seal to the torque converter clutch case.

NOTE:

Be careful not to lose the rubber seal.

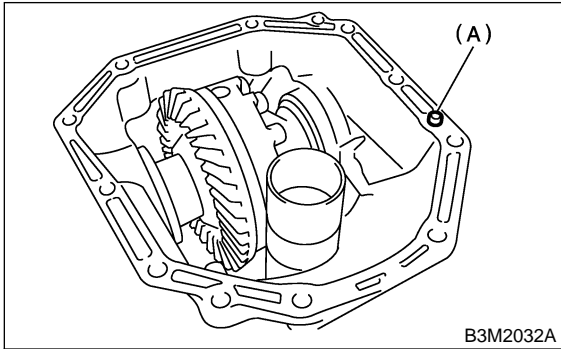

(A) Rubber seal

7) Apply proper amount of liquid gasket to the entire torque converter clutch case mating surface.

**Liquid gasket:**

**THREE BOND 1215**

NOTE:

Make sure that the rubber seal and seal pipe are fitted in position.

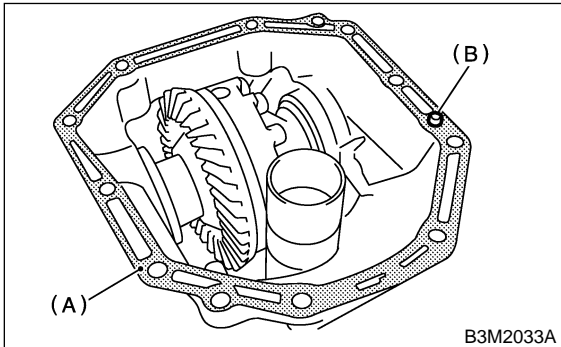

(A) THREE BOND (Part No. 1215)

(B) Rubber seal

8) Install the torque converter clutch case assembly to the transmission case assembly, and secure with six bolts and four nuts.

NOTE:

When installing, be careful not to damage the torque converter clutch case bushing and oil seal.

**Tightening torque:**

**41 N·m (4.2 kgf-m, 30.4 ft-lb)**

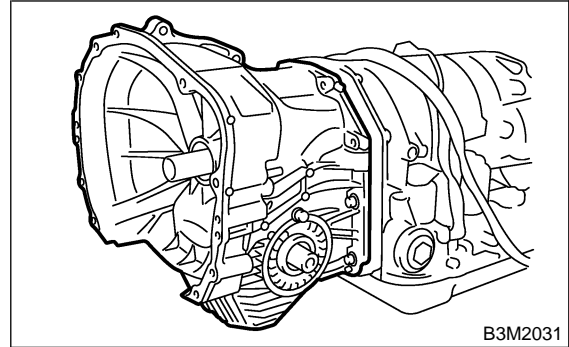

9) Install the pitching stopper bracket.

**Tightening torque:**

**41 N·m (4.2 kgf-m, 30.4 ft-lb)**

● 3.0 L and TURBO models

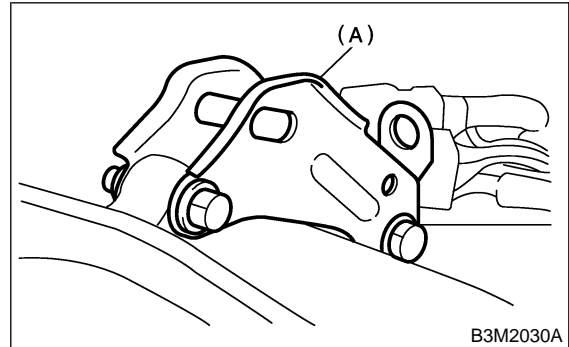

(A) Pitching stopper

● Except 3.0 L and TURBO models

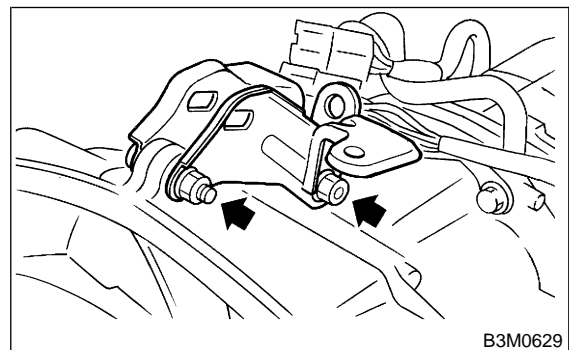

10) Insert inhibitor switch and transmission connector into stay.

11) Install air breather hose. <Ref. to AT-28, INSTALLATION, Air Breather Hose.>

- 12) Install the oil cooler pipes. <Ref. to AT-30, INSTALLATION, Oil Cooler Pipes.>
- 13) Install the oil charger pipe with O-ring. <Ref. to AT-29, INSTALLATION, Oil Charger Pipe.>
- 14) Insert the input shaft while turning lightly by hand.

**CAUTION:**

**Be careful not to damage the bushing.**

**Normal protrusion A:**

**50 — 55 mm (1.97 — 2.17 in)**

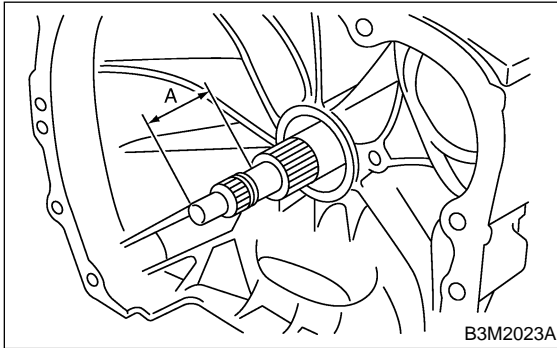

- 15) Install the torque converter clutch assembly. <Ref. to AT-35, INSTALLATION, Torque Converter Clutch Assembly.>

**C: INSPECTION**

S510206A10

Measure the backlash and adjust to within specifications. <Ref. to AT-71, ADJUSTMENT, Drive Pinion Shaft.>



## 18. Oil Pump S510070

### A: REMOVAL S510070A18

- 1) Extract the torque converter clutch assembly. <Ref. to AT-35, REMOVAL, Torque Converter Clutch Assembly.>
- 2) Remove the input shaft.

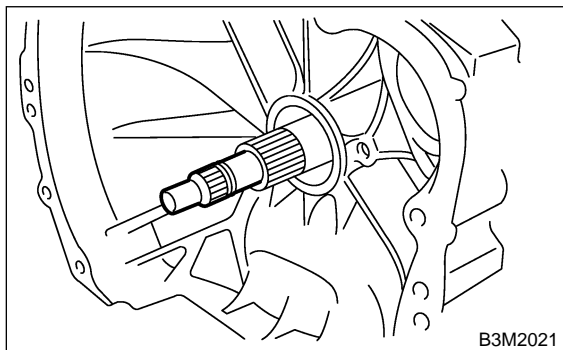

- 3) Disconnect transmission harness connector from stay.

**NOTE:**

Lift-up lever behind the connector and disconnect it from stay.

- 4) Disconnect inhibitor switch connector from stay.
- 5) Disconnect the air breather hose. <Ref. to AT-28, REMOVAL, Air Breather Hose.>
- 6) Remove the oil charger pipe. <Ref. to AT-29, REMOVAL, Oil Charger Pipe.>
- 7) Remove the oil cooler inlet and outlet pipes. <Ref. to AT-30, REMOVAL, Oil Cooler Pipes.>
- 8) Separation of torque converter clutch case and transmission case sections <Ref. to AT-58, REMOVAL, Torque Converter Clutch Case.>
- 9) Separate transmission case and extension case sections. <Ref. to AT-36, REMOVAL, Extension Case.>
- 10) Remove the reduction driven gear. Without VTD <Ref. to AT-48, WITHOUT VTD, REMOVE, Reduction Driven Gear.> With VTD <Ref. to AT-48, WITH VTD, REMOVE, Reduction Driven Gear.>
- 11) Loosen the taper roller bearing mounting bolts.

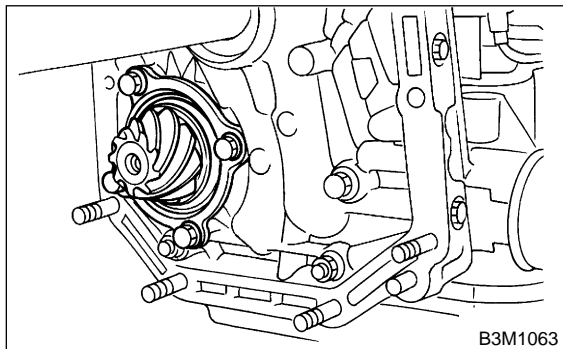

- 12) Place two wooden blocks on the workbench, and stand the transmission case with its rear end facing down.

**CAUTION:**

- Be careful not to scratch the rear mating surface of the transmission case.
- Note that the parking rod and drive pinion protrude from the mating surface.

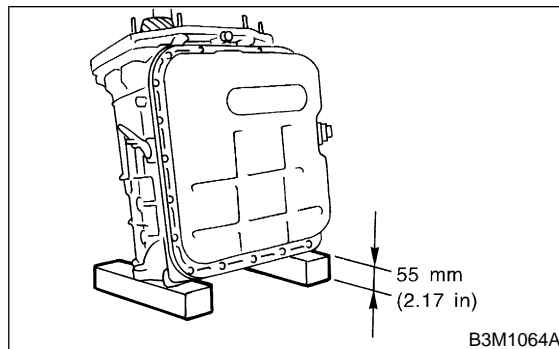

- 13) Remove the oil pump housing and adjusting thrust washer.

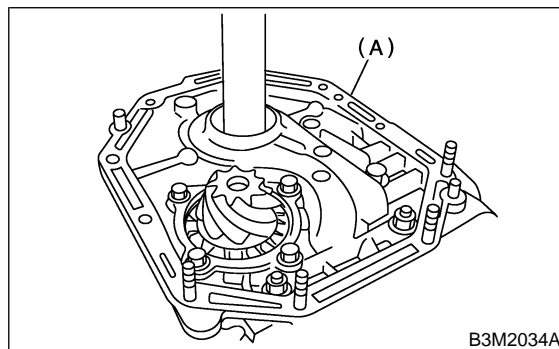

(A) Oil pump housing

- 14) Remove the oil seal retainer. Also remove the O-ring and oil seal (air breather).

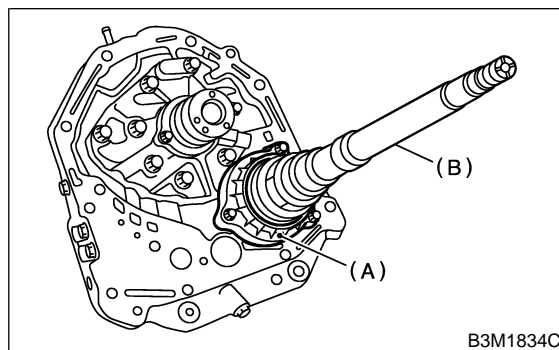

(A) Oil seal retainer  
(B) Drive pinion shaft

- 15) Remove O-rings from oil pump housing.

**NOTE:**

Do not re-use O-ring. Prepare a new one.

- 16) Remove the drive pinion assembly.

## B: INSTALLATION S510070A11

1) Assemble the drive pinion assembly to the oil pump housing.

**NOTE:**

- Be careful not to bend the shims.
- Be careful not to force the pinion against the housing bore.

2) Tighten four bolts to secure the roller bearing.

**Tightening torque:**

**40 N·m (4.1 kgf-m, 30 ft-lb)**

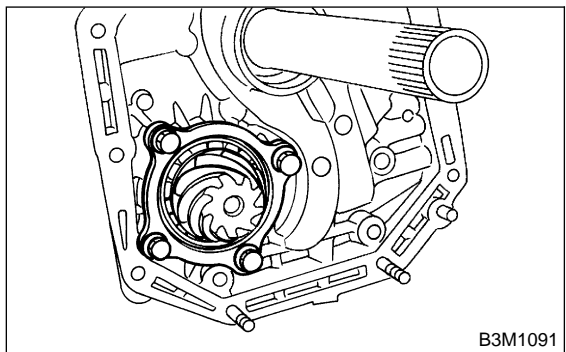

3) Install two new oil seals to the oil seal retainer with ST.

**NOTE:**

Pay attention to the orientation of the oil seals.

ST 499247300 INSTALLER

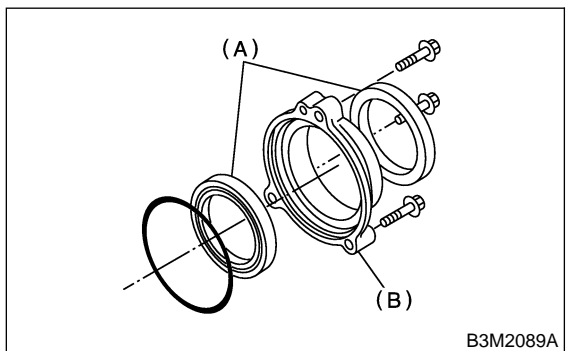

- (A) Oil seal
- (B) Oil seal retainer

4) Attach the new O-ring to the oil seal retainer with vaseline. Install the seal to the oil pump housing bore.

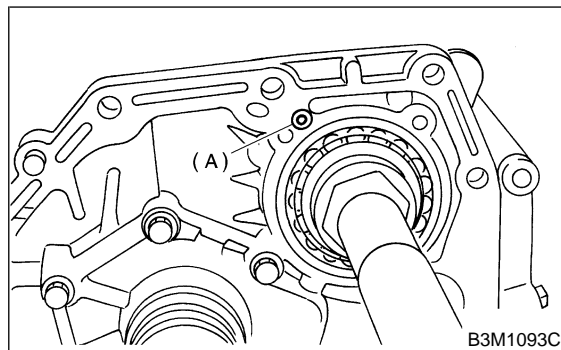

- (A) O-ring

5) Install the oil seal retainer taking care not to damage the oil seal lips. Then secure with three bolts.

**NOTE:**

Make sure the O-ring is fitted correctly in position.

**Tightening torque:**

**7 N·m (0.7 kgf-m, 5.1 ft-lb)**

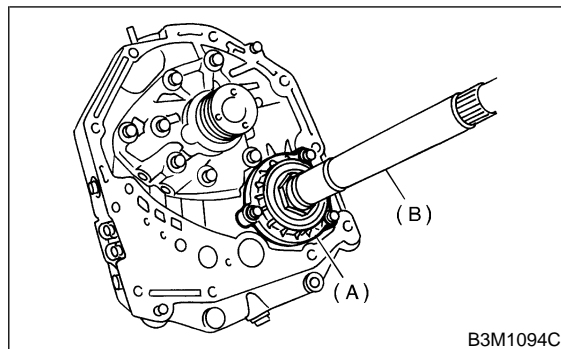

- (A) Oil seal retainer
- (B) Drive pinion shaft

6) Secure the housing with two nuts and the bolt.

**Tightening torque:**

**42 N·m (4.3 kgf-m, 31 ft-lb)**

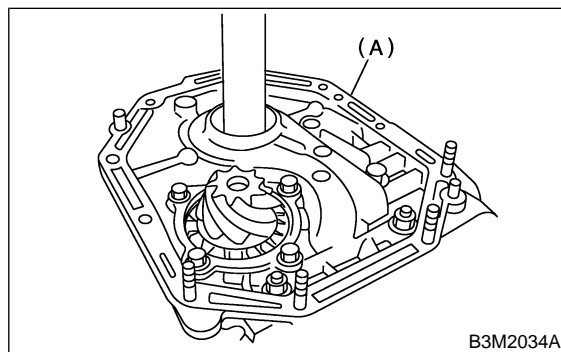

- (A) Oil pump housing

# OIL PUMP

## Automatic Transmission

7) Install the torque converter clutch case assembly to the transmission case assembly. <Ref. to AT-35, INSTALLATION, Torque Converter Clutch Assembly.>

8) Install reduction driven gear. <Ref. to AT-48, WITHOUT VTD, INSTALLATION, Reduction Driven Gear.> <Ref. to AT-49, WITH VTD, INSTALLATION, Reduction Driven Gear.>

9) Combine the extension case with the transmission case, and install vehicle speed sensor 1 (rear). <Ref. to AT-36, INSTALLATION, Extension Case.>

10) Insert inhibitor switch and transmission connector into stay.

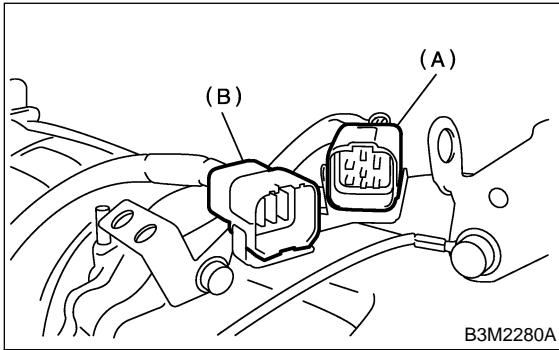

- (A) Transmission harness
- (B) Inhibitor switch harness

11) Install air breather hose. <Ref. to AT-28, INSTALLATION, Air Breather Hose.>

12) Install the oil cooler pipe. <Ref. to AT-30, INSTALLATION, Oil Cooler Pipe.>

13) Install the oil charger pipe with O-ring. <Ref. to AT-29, INSTALLATION, Oil Charger Pipes.>

14) Insert the input shaft while turning lightly by hand.

### NOTE:

Be careful not to damage the bushing.

### Normal protrusion A:

50 — 55 mm (1.97 — 2.17 in)

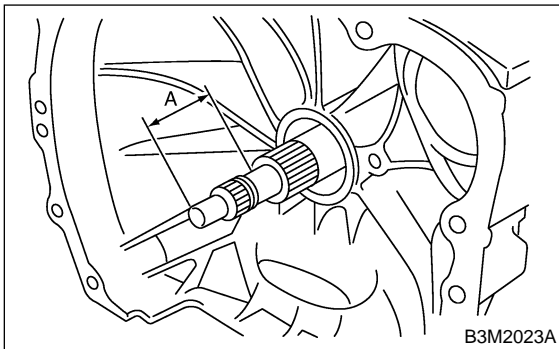

15) Install the torque converter clutch assembly. <Ref. to AT-35, INSTALLATION, Torque Converter Clutch Assembly.>

## C: DISASSEMBLY S510070A06

1) Remove four seal rings.

### NOTE:

Do not re-use O-ring. Prepare a new one.

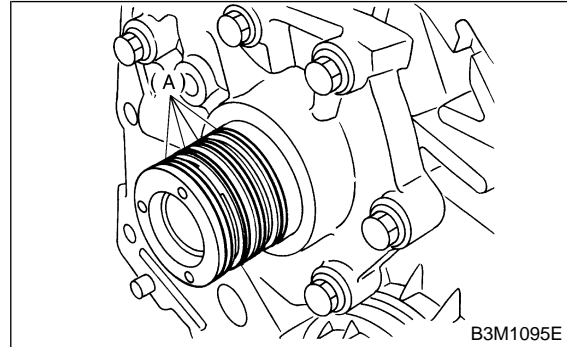

- (A) Seal rings

2) Remove the oil pump cover.

### NOTE:

Lightly tap the end of the stator shaft to remove the cover.

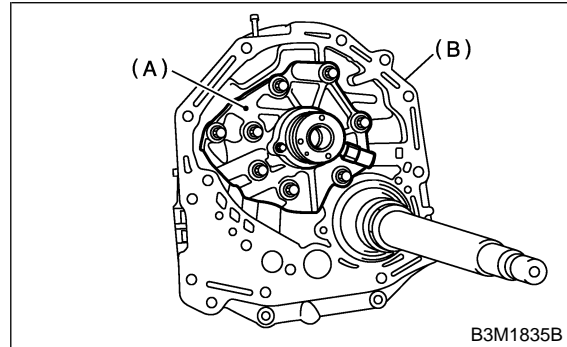

- (A) Oil pump cover
- (B) Oil pump housing

3) Remove the inner and outer rotor.

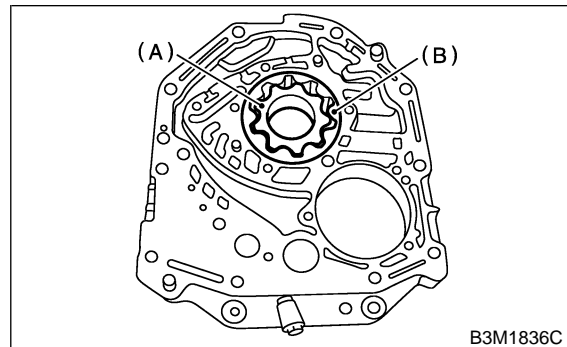

- (A) Inner rotor
- (B) Outer rotor

## D: ASSEMBLY S510070A02

1) Install oil pump rotor assembly to oil pump housing.

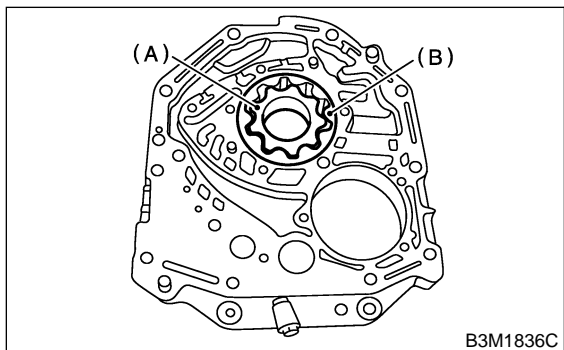

- (A) Inner rotor
- (B) Outer rotor

2) Install the oil pump cover.

### Tightening torque:

**25 N·m (2.5 kgf-m, 18.1 ft-lb)**

### NOTE:

- Align both pivots with the pivot holes of the cover, and install the cover being careful not to apply undue force to the pivots.
- After assembling, turn the oil pump shaft to check for smooth rotation of the rotor.

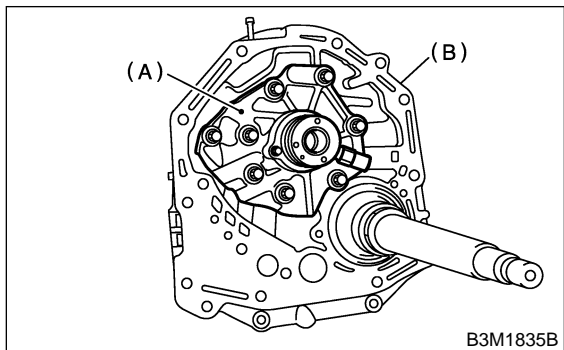

- (A) Oil pump cover
- (B) Oil pump housing

3) Install the oil seal retainer and new seal rings. After adjusting the drive pinion backlash and tooth contact. <Ref. to AT-66, ADJUSTMENT, Oil Pump.>

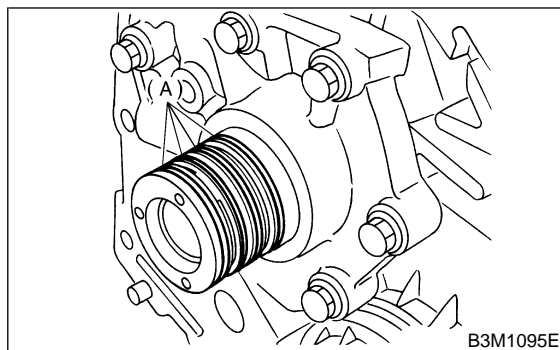

- (A) Seal rings

## E: INSPECTION S510070A10

- 1) Check seal ring and O-ring oil seal for breaks or damage.
- 2) Check other parts for dents or abnormalities.
- 3) Selection of oil pump rotor assembly
  - (1) Tip clearance  
Install inner rotor and outer rotor to oil pump. With rotor gears facing each other, measure crest-to-crest clearance.

### Tip clearance:

**0.02 — 0.15 mm (0.0008 — 0.0059 in)**

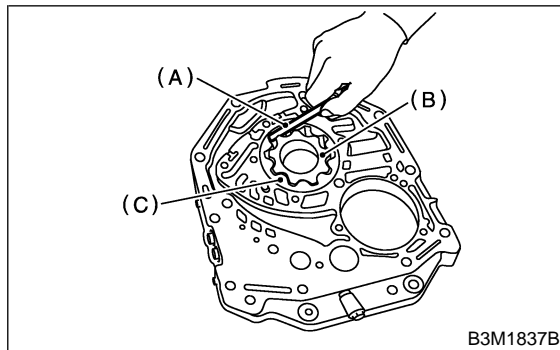

- (A) Thickness gauge
- (B) Inner rotor
- (C) Outer rotor

# OIL PUMP

Automatic Transmission

## (2) Side clearance

Set a depth gauge to oil pump housing, then measure oil pump housing-to-rotor clearances.

### Side clearance:

0.02 — 0.04 mm (0.0008 — 0.0016 in)

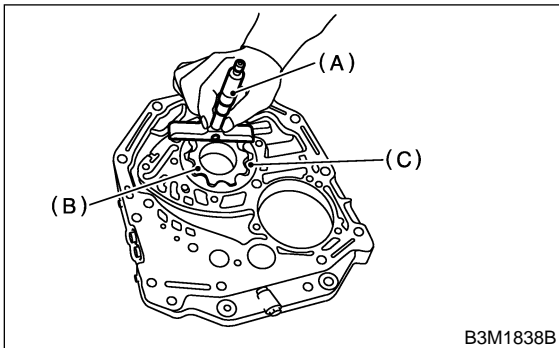

- (A) Depth gauge
- (B) Inner rotor
- (C) Outer rotor

(3) If depth and/or side clearances are outside specifications, replace rotor assembly.

Oil pump rotor assembly	
Part No.	Thickness mm (in)
15008AA060	11.37 — 11.38 (0.4476 — 0.4480)
15008AA070	11.38 — 11.39 (0.4480 — 0.4484)
15008AA080	11.39 — 11.40 (0.4484 — 0.4488)

● Measure the total end play and adjust to within specifications. <Ref. to AT-66, ADJUSTMENT, Oil Pump.>

## F: ADJUSTMENT SS10070A01

1) Using ST, measure the distance from the transmission case mating surface to the recessed portion of the high clutch drum "L".

ST 398643600 GAUGE

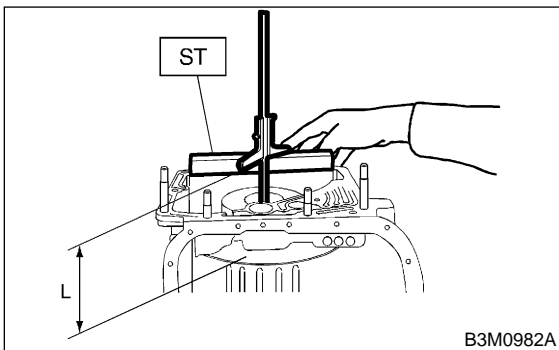

2) Using ST, measure the distance from the oil pump housing mating surface to the top surface of the oil pump cover with thrust needle bearing.

ST 398643600 GAUGE

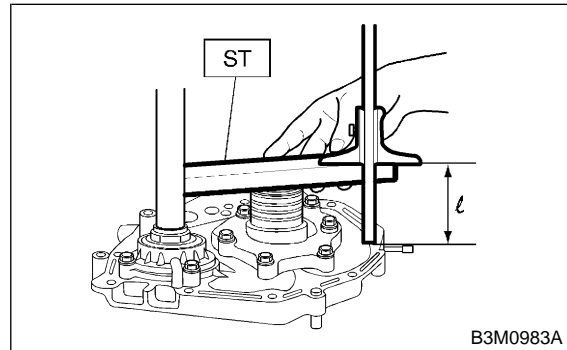

## 3) Calculation of total end play

Select suitable bearing race from among those listed in this table so that clearance C is in the 0.25 to 0.55 mm (0.0098 to 0.0217 in) range.

$$C = (L + G) - \ell$$

C	Clearance between concave portion of high clutch and end of clutch drum support
L	Length from case mating surface to concave portion of high clutch
G	Gasket thickness [0.28 mm (0.0110 in)]
$\ell$	Height from housing mating surface to upper surface of clutch drum support

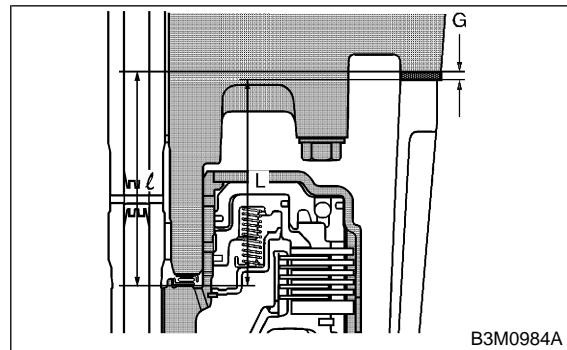

Thrust needle bearing	
Part No.	Thickness mm (in)
806528050	4.1 (0.161)
806528060	4.3 (0.169)
806528070	4.5 (0.177)
806528080	4.7 (0.185)
806528090	4.9 (0.193)
806528100	5.1 (0.201)

4) After completing end play adjustment, insert the bearing race in the recess of the high clutch. Attach the thrust needle bearing to the oil pump cover with vaseline.

5) After correctly installing the new gasket to the case mating surface, carefully install the oil pump housing assembly. Be careful to avoid hitting the drive pinion against the inside of the case.

**NOTE:**

Be careful not to damage the seal ring.

6) Install both parts with dowel pins aligned. Make sure no clearance exists at the mating surface.

**NOTE:**

Any clearance suggests a damaged seal ring.

## 18. Oil Pump S510070

### A: REMOVAL S510070A18

- 1) Extract the torque converter clutch assembly. <Ref. to AT-35, REMOVAL, Torque Converter Clutch Assembly.>
- 2) Remove the input shaft.

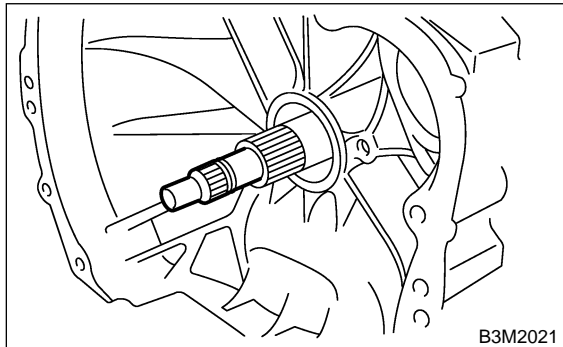

- 3) Disconnect transmission harness connector from stay.

**NOTE:**

Lift-up lever behind the connector and disconnect it from stay.

- 4) Disconnect inhibitor switch connector from stay.
- 5) Disconnect the air breather hose. <Ref. to AT-28, REMOVAL, Air Breather Hose.>
- 6) Remove the oil charger pipe. <Ref. to AT-29, REMOVAL, Oil Charger Pipe.>
- 7) Remove the oil cooler inlet and outlet pipes. <Ref. to AT-30, REMOVAL, Oil Cooler Pipes.>
- 8) Separation of torque converter clutch case and transmission case sections <Ref. to AT-58, REMOVAL, Torque Converter Clutch Case.>
- 9) Separate transmission case and extension case sections. <Ref. to AT-36, REMOVAL, Extension Case.>
- 10) Remove the reduction driven gear. Without VTD <Ref. to AT-48, WITHOUT VTD, REMOVE, Reduction Driven Gear.> With VTD <Ref. to AT-48, WITH VTD, REMOVE, Reduction Driven Gear.>
- 11) Loosen the taper roller bearing mounting bolts.

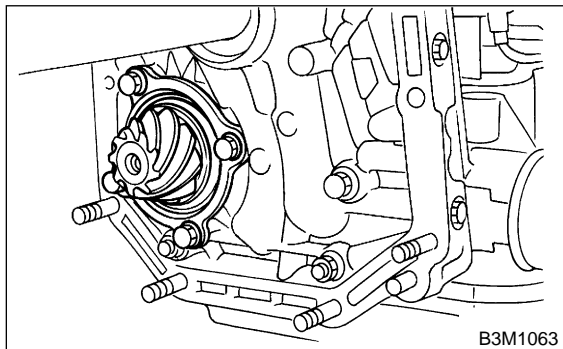

- 12) Place two wooden blocks on the workbench, and stand the transmission case with its rear end facing down.

**CAUTION:**

- Be careful not to scratch the rear mating surface of the transmission case.
- Note that the parking rod and drive pinion protrude from the mating surface.

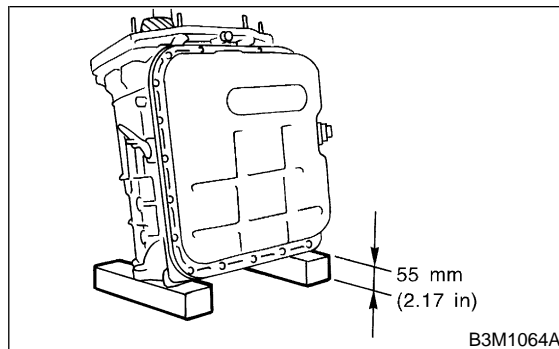

- 13) Remove the oil pump housing and adjusting thrust washer.

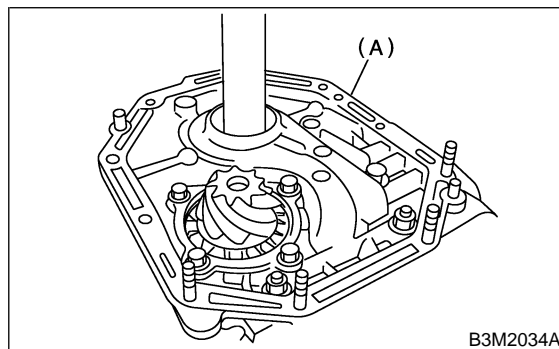

(A) Oil pump housing

- 14) Remove the oil seal retainer. Also remove the O-ring and oil seal (air breather).

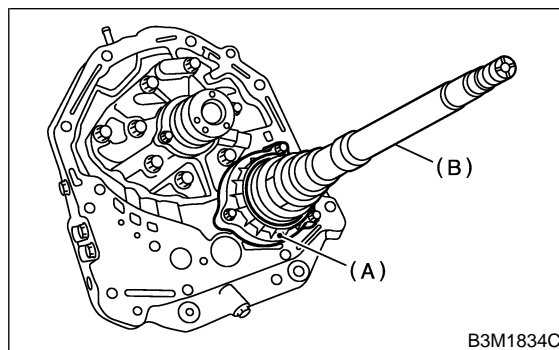

(A) Oil seal retainer  
(B) Drive pinion shaft

- 15) Remove O-rings from oil pump housing.

**NOTE:**

Do not re-use O-ring. Prepare a new one.

- 16) Remove the drive pinion assembly.

## B: INSTALLATION S510070A11

1) Assemble the drive pinion assembly to the oil pump housing.

**NOTE:**

- Be careful not to bend the shims.
- Be careful not to force the pinion against the housing bore.

2) Tighten four bolts to secure the roller bearing.

**Tightening torque:**

**40 N·m (4.1 kgf-m, 30 ft-lb)**

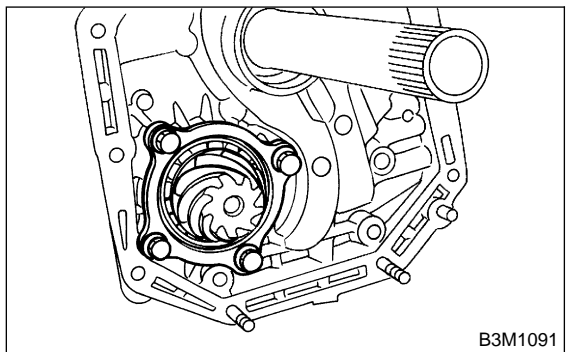

3) Install two new oil seals to the oil seal retainer with ST.

**NOTE:**

Pay attention to the orientation of the oil seals.

ST 499247300 INSTALLER

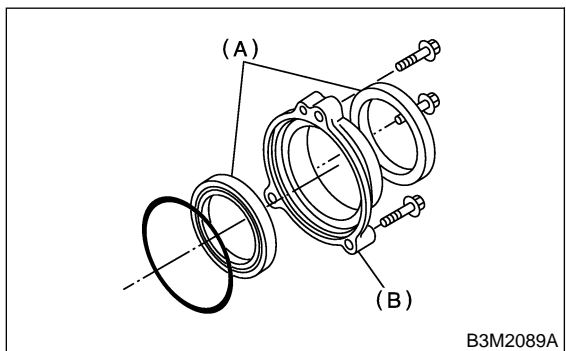

- (A) Oil seal
- (B) Oil seal retainer

4) Attach the new O-ring to the oil seal retainer with vaseline. Install the seal to the oil pump housing bore.

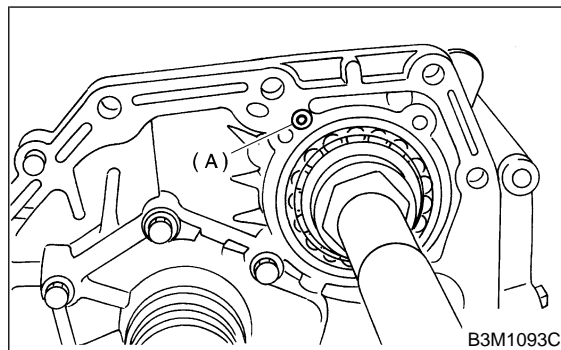

- (A) O-ring

5) Install the oil seal retainer taking care not to damage the oil seal lips. Then secure with three bolts.

**NOTE:**

Make sure the O-ring is fitted correctly in position.

**Tightening torque:**

**7 N·m (0.7 kgf-m, 5.1 ft-lb)**

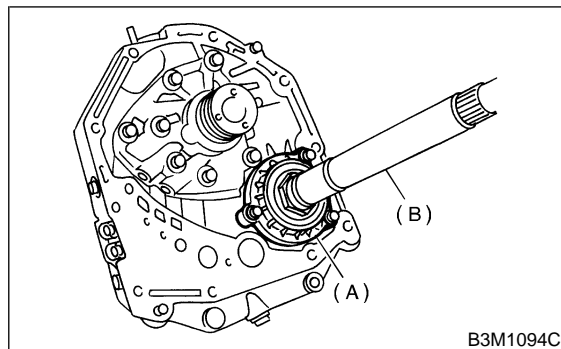

- (A) Oil seal retainer
- (B) Drive pinion shaft

6) Secure the housing with two nuts and the bolt.

**Tightening torque:**

**42 N·m (4.3 kgf-m, 31 ft-lb)**

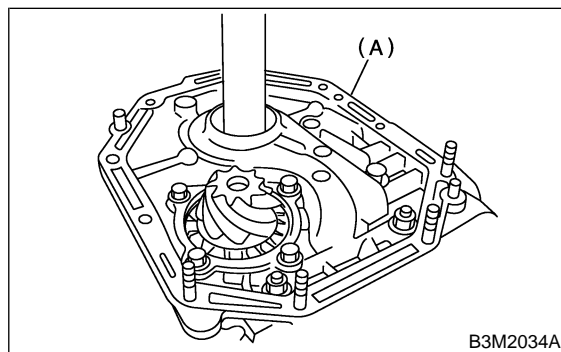

- (A) Oil pump housing



# OIL PUMP

## Automatic Transmission

7) Install the torque converter clutch case assembly to the transmission case assembly. <Ref. to AT-35, INSTALLATION, Torque Converter Clutch Assembly.>

8) Install reduction driven gear. <Ref. to AT-48, WITHOUT VTD, INSTALLATION, Reduction Driven Gear.> <Ref. to AT-49, WITH VTD, INSTALLATION, Reduction Driven Gear.>

9) Combine the extension case with the transmission case, and install vehicle speed sensor 1 (rear). <Ref. to AT-36, INSTALLATION, Extension Case.>

10) Insert inhibitor switch and transmission connector into stay.

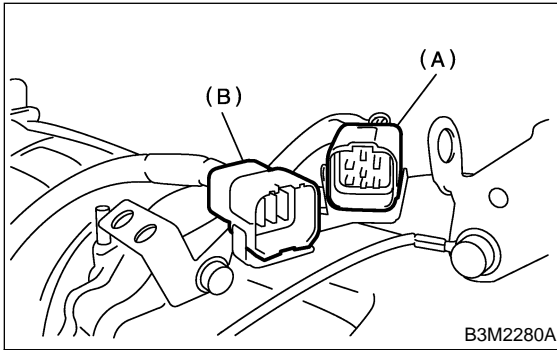

- (A) Transmission harness
- (B) Inhibitor switch harness

11) Install air breather hose. <Ref. to AT-28, INSTALLATION, Air Breather Hose.>

12) Install the oil cooler pipe. <Ref. to AT-30, INSTALLATION, Oil Cooler Pipe.>

13) Install the oil charger pipe with O-ring. <Ref. to AT-29, INSTALLATION, Oil Charger Pipes.>

14) Insert the input shaft while turning lightly by hand.

### NOTE:

Be careful not to damage the bushing.

### Normal protrusion A:

50 — 55 mm (1.97 — 2.17 in)

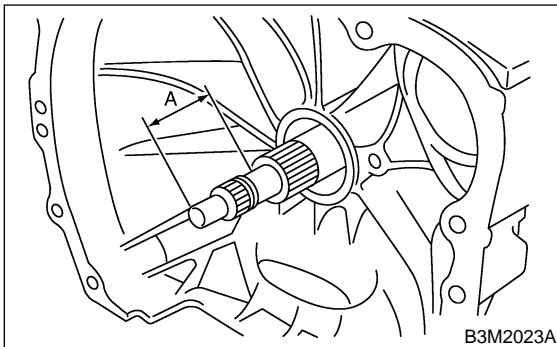

15) Install the torque converter clutch assembly. <Ref. to AT-35, INSTALLATION, Torque Converter Clutch Assembly.>

## C: DISASSEMBLY S510070A06

1) Remove four seal rings.

### NOTE:

Do not re-use O-ring. Prepare a new one.

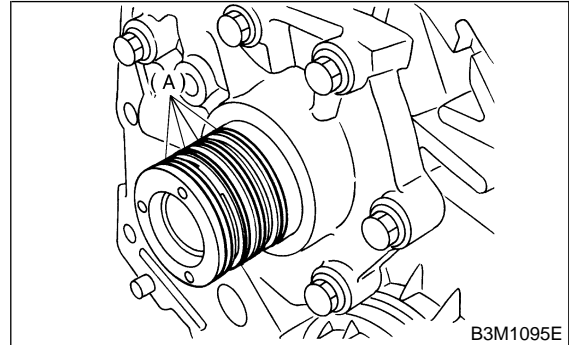

- (A) Seal rings

2) Remove the oil pump cover.

### NOTE:

Lightly tap the end of the stator shaft to remove the cover.

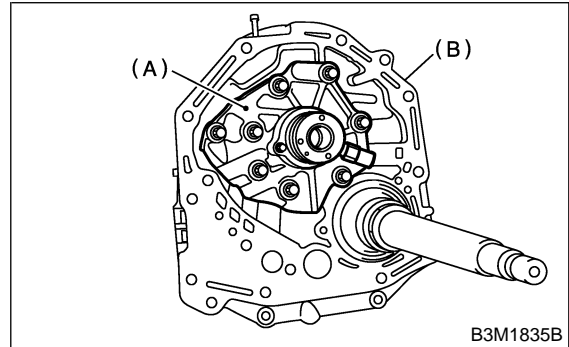

- (A) Oil pump cover
- (B) Oil pump housing

3) Remove the inner and outer rotor.

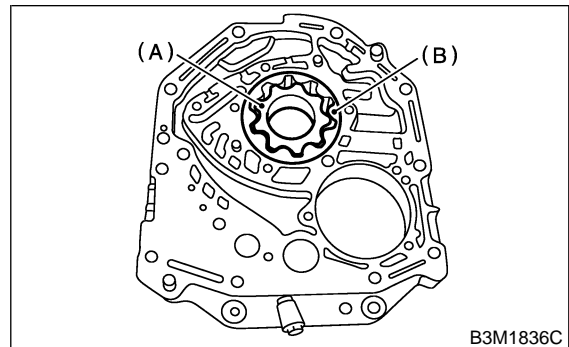

- (A) Inner rotor
- (B) Outer rotor

## D: ASSEMBLY S510070A02

1) Install oil pump rotor assembly to oil pump housing.

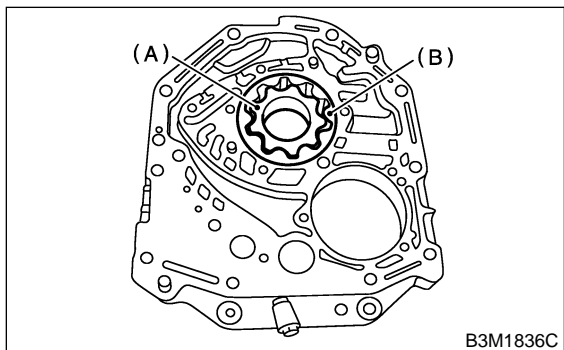

- (A) Inner rotor
- (B) Outer rotor

2) Install the oil pump cover.

### Tightening torque:

**25 N·m (2.5 kgf-m, 18.1 ft-lb)**

### NOTE:

- Align both pivots with the pivot holes of the cover, and install the cover being careful not to apply undue force to the pivots.
- After assembling, turn the oil pump shaft to check for smooth rotation of the rotor.

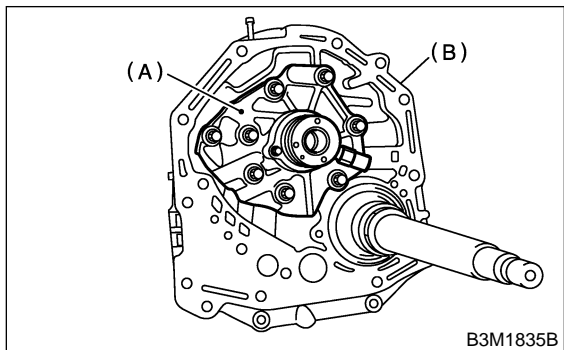

- (A) Oil pump cover
- (B) Oil pump housing

3) Install the oil seal retainer and new seal rings. After adjusting the drive pinion backlash and tooth contact. <Ref. to AT-66, ADJUSTMENT, Oil Pump.>

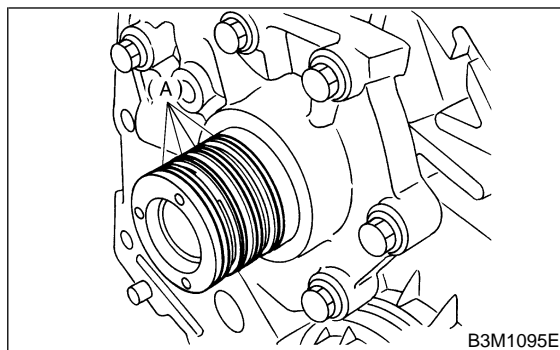

- (A) Seal rings

## E: INSPECTION S510070A10

- 1) Check seal ring and O-ring oil seal for breaks or damage.
- 2) Check other parts for dents or abnormalities.
- 3) Selection of oil pump rotor assembly
  - (1) Tip clearance  
Install inner rotor and outer rotor to oil pump. With rotor gears facing each other, measure crest-to-crest clearance.

### Tip clearance:

**0.02 — 0.15 mm (0.0008 — 0.0059 in)**

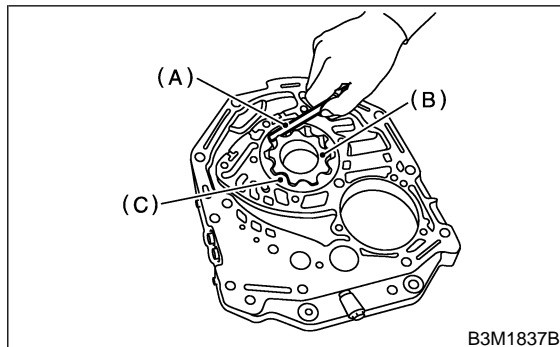

- (A) Thickness gauge
- (B) Inner rotor
- (C) Outer rotor

# OIL PUMP

Automatic Transmission

## (2) Side clearance

Set a depth gauge to oil pump housing, then measure oil pump housing-to-rotor clearances.

### Side clearance:

0.02 — 0.04 mm (0.0008 — 0.0016 in)

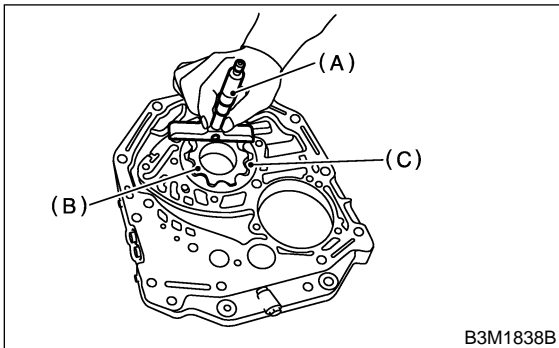

- (A) Depth gauge
- (B) Inner rotor
- (C) Outer rotor

(3) If depth and/or side clearances are outside specifications, replace rotor assembly.

Oil pump rotor assembly	
Part No.	Thickness mm (in)
15008AA060	11.37 — 11.38 (0.4476 — 0.4480)
15008AA070	11.38 — 11.39 (0.4480 — 0.4484)
15008AA080	11.39 — 11.40 (0.4484 — 0.4488)

● Measure the total end play and adjust to within specifications. <Ref. to AT-66, ADJUSTMENT, Oil Pump.>

## F: ADJUSTMENT SS10070A01

1) Using ST, measure the distance from the transmission case mating surface to the recessed portion of the high clutch drum "L".

ST 398643600 GAUGE

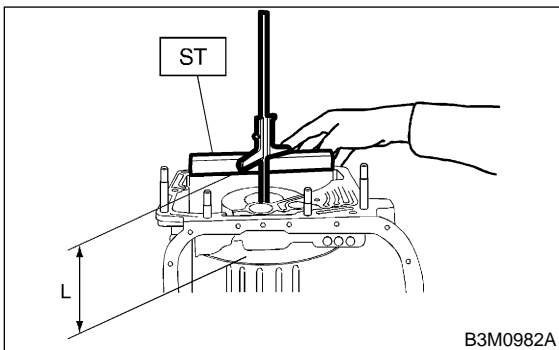

2) Using ST, measure the distance from the oil pump housing mating surface to the top surface of the oil pump cover with thrust needle bearing.

ST 398643600 GAUGE

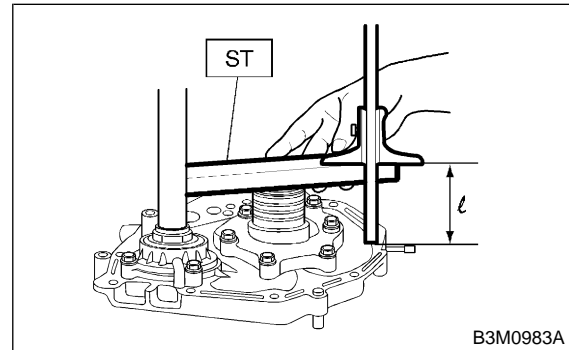

## 3) Calculation of total end play

Select suitable bearing race from among those listed in this table so that clearance C is in the 0.25 to 0.55 mm (0.0098 to 0.0217 in) range.

$$C = (L + G) - \ell$$

C	Clearance between concave portion of high clutch and end of clutch drum support
L	Length from case mating surface to concave portion of high clutch
G	Gasket thickness [0.28 mm (0.0110 in)]
$\ell$	Height from housing mating surface to upper surface of clutch drum support

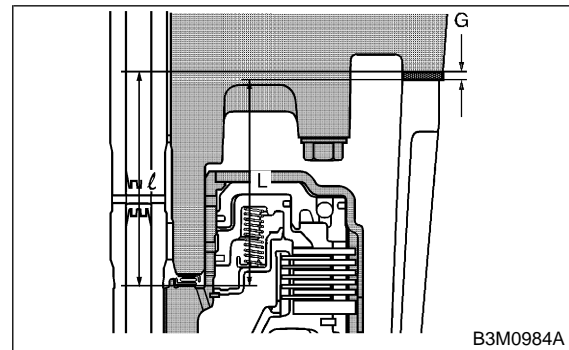

Thrust needle bearing	
Part No.	Thickness mm (in)
806528050	4.1 (0.161)
806528060	4.3 (0.169)
806528070	4.5 (0.177)
806528080	4.7 (0.185)
806528090	4.9 (0.193)
806528100	5.1 (0.201)

4) After completing end play adjustment, insert the bearing race in the recess of the high clutch. Attach the thrust needle bearing to the oil pump cover with vaseline.

5) After correctly installing the new gasket to the case mating surface, carefully install the oil pump housing assembly. Be careful to avoid hitting the drive pinion against the inside of the case.

**NOTE:**

Be careful not to damage the seal ring.

6) Install both parts with dowel pins aligned. Make sure no clearance exists at the mating surface.

**NOTE:**

Any clearance suggests a damaged seal ring.

## 19. Drive Pinion Shaft S510216

### A: REMOVAL S510216A18

- 1) Extract the torque converter clutch assembly. <Ref. to AT-35, REMOVAL, Torque Converter Clutch Assembly.>
- 2) Remove the input shaft.

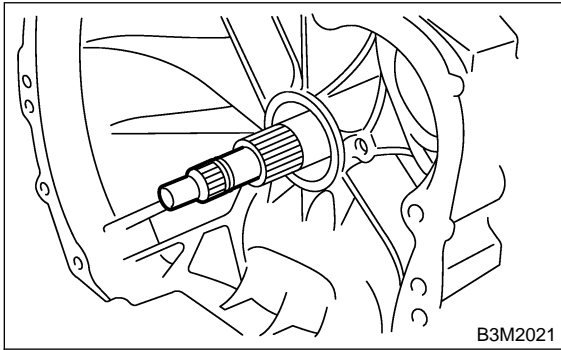

- 3) Disconnect transmission harness connector from stay.

**NOTE:**

Lift-up lever behind the connector and disconnect it from stay.

- 4) Disconnect inhibitor switch connector from stay.
- 5) Disconnect the air breather hose. <Ref. to AT-28, REMOVAL, Air Breather Hose.>
- 6) Remove the oil charger pipe. <Ref. to AT-29, REMOVAL, Oil Charger Pipe.>
- 7) Remove the oil cooler inlet and outlet pipes. <Ref. to AT-30, REMOVAL, Oil Cooler Pipes.>
- 8) Separation of torque converter clutch case and transmission case sections <Ref. to AT-58, REMOVAL, Torque Converter Clutch Case.>
- 9) Separate transmission case and extension case sections. <Ref. to AT-36, REMOVAL, Extension Case.>
- 10) Remove the reduction driven gear.  
Without VTD <Ref. to AT-48, WITHOUT VTD, REMOVAL, Reduction Driven Gear.>  
With VTD <Ref. to AT-48, WITH VTD, REMOVAL, Reduction Driven Gear.>
- 11) Separation of drive pinion shaft and oil pump housing. <Ref. to AT-62, REMOVAL, Oil Pump.>

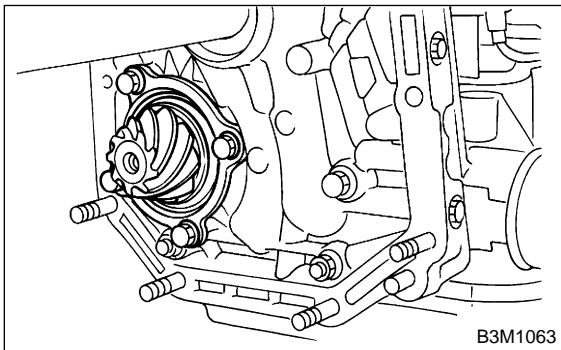

### B: INSTALLATION S510216A11

- 1) Assemble the drive pinion assembly to the oil pump housing. <Ref. to AT-63, INSTALLATION, Oil Pump.>
- 2) Install oil pump housing to transmission case. <Ref. to AT-63, INSTALLATION, Oil Pump.>
- 3) Combine the torque converter case with the transmission case. <Ref. to AT-59, INSTALLATION, Torque Converter Clutch Case.>
- 4) Install the reduction driven gear.  
Without VTD <Ref. to AT-48, WITHOUT VTD, INSTALLATION, Reduction Driven Gear.>  
With VTD <Ref. to AT-49, WITH VTD, INSTALLATION, Reduction Driven Gear.>
- 5) Combine the extension case with the transmission case, and install vehicle speed sensor 1 (rear). <Ref. to AT-36, INSTALLATION, Extension Case.>
- 6) Insert inhibitor switch and transmission connector into stay.
- 7) Install air breather hose. <Ref. to AT-28, INSTALLATION, Air Breather Hose.>
- 8) Install the oil charger pipe with O-ring.
- 9) Insert the input shaft while turning lightly by hand.

**CAUTION:**

Be careful not to damage the bushing.

**Normal protrusion A:**

**50 — 55 mm (1.97 — 2.17 in)**

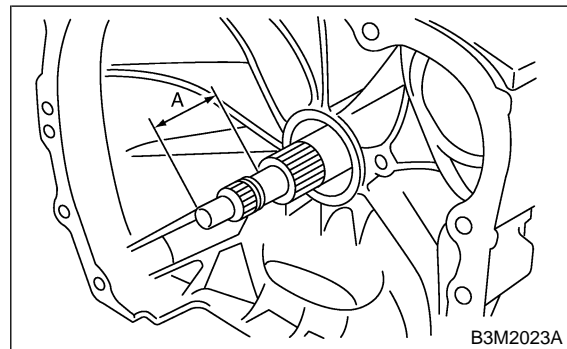

- 10) Install the torque converter clutch assembly. <Ref. to AT-35, INSTALLATION, Torque Converter Clutch Assembly.>

## C: DISASSEMBLY S510216A06

1) Straighten the staked portion of the lock nut, and remove the lock nut while locking the rear spline portion of the shaft with ST1 and ST2. Then pull off the drive pinion collar.

ST1 498937110 HOLDER  
 ST2 499787700 WRENCH  
 ST3 499787500 ADAPTER

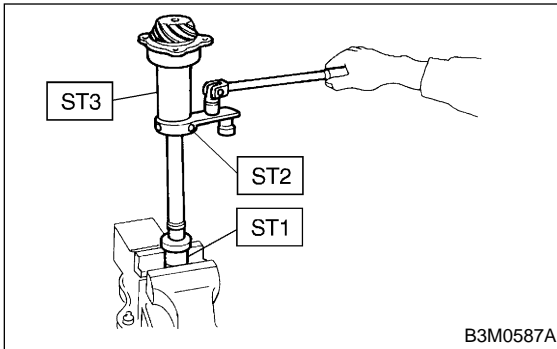

2) Remove the O-ring.  
 3) Using a press, separate the rear roller bearing and outer race from the shaft.

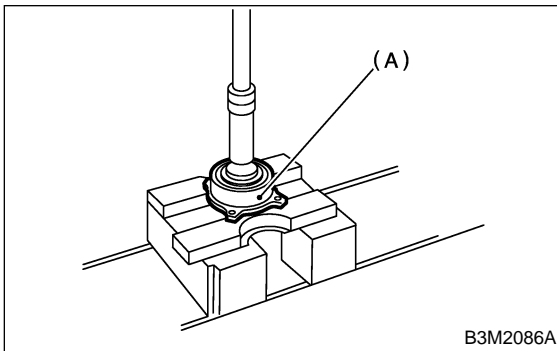

(A) Outer race

4) Using a press and ST, separate the front roller bearing from the shaft.  
 ST 498517000 REPLACER

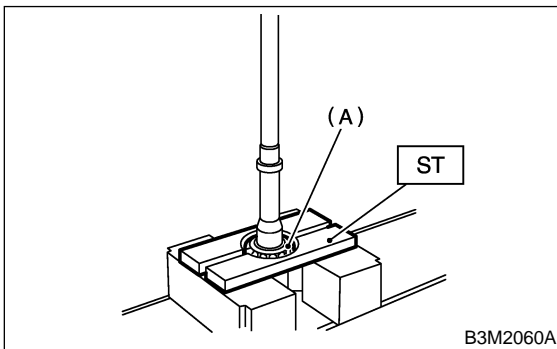

(A) Front roller bearing

## D: ASSEMBLY S510216A02

1) Measure dimension "A" of the drive pinion shaft.  
 ST 398643600 GAUGE

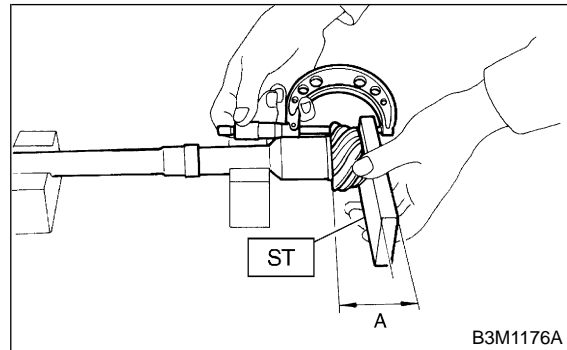

2) Using a press, force-fit the roller bearing in position.

**CAUTION:**  
 Do not change the relative positions of the outer race and bearing cone.

**NOTE:**  
 If too much pressure is applied, the roller bearing will not turn easily.

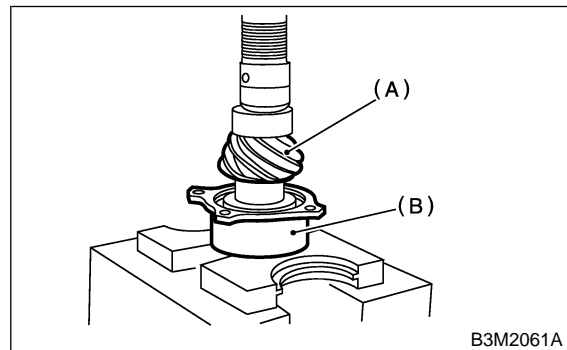

(A) Drive pinion shaft  
 (B) Roller bearing

3) After fitting the O-ring to the shaft, attach the drive pinion collar to the shaft.

**NOTE:**  
 Be careful not to damage the O-ring.

# DRIVE PINION SHAFT

Automatic Transmission

4) Tighten the lock washer and lock nut with ST1, ST2 and ST3.

Calculate lock washer and lock nut specifications using the following formula.

$$T2 = L2 / (L1 + L2) \times T1$$

T1: 116 N·m (11.8 kgf·m, 85.3 ft·lb)

[Required torque setting]

T2: Tightening torque

L1: ST2 length 0.072 m (2.83 in)

L2: Torque wrench length

Example:

Torque wrench length m (in)	Tightening torque N·m (kgf·m, ft·lb)
0.4 (15.75)	98 (10.0, 72)
0.45 (17.72)	100 (10.2, 73.8)
0.5 (19.69)	101 (10.3, 74.5)
0.55 (21.65)	102 (10.4, 75)

ST1 498937110 HOLDER

ST2 499787700 WRENCH

ST3 499787500 ADAPTER

NOTE:

- Pay attention to the orientation of lock washer.
- Install ST2 to torque wrench as straight as possible.

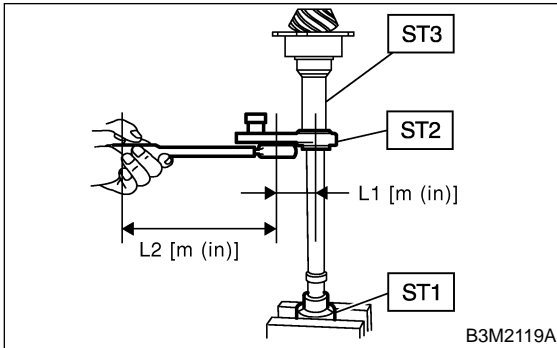

5) Measure the starting torque of the bearing. Make sure the starting torque is within the specified range. If out of the allowable range, replace the roller bearing.

**Starting torque:**

**7.6 — 38.1 N (0.776 — 3.88 kgf, 5.6 — 28.1 ft)**

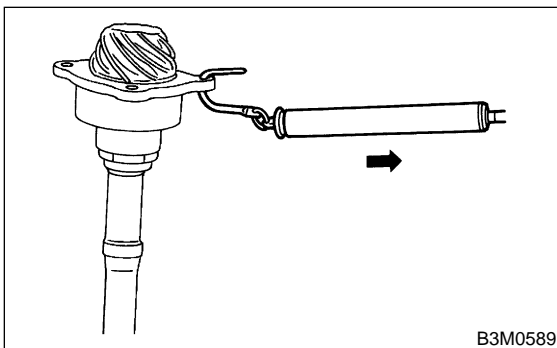

6) Stake the lock nut securely at two places.

7) Measure dimension "B" of the drive pinion shaft.

ST 398643600 GAUGE

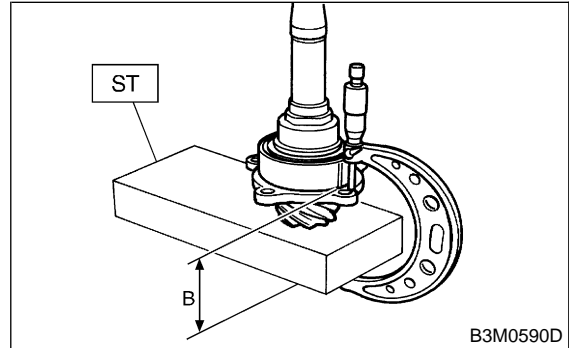

8) Determine the thickness "t" (mm) of the drive pinion shim.

NOTE:

The number of shims must be three or less.

$$t = 6.5 \pm 0.0625 - (B - A)$$

Available drive pinion shims	
Part No.	Thickness mm (in)
31451AA050	0.150 (0.0059)
31451AA060	0.175 (0.0069)
31451AA070	0.200 (0.0079)
31451AA080	0.225 (0.0089)
31451AA090	0.250 (0.0098)
31451AA100	0.275 (0.0108)

## E: INSPECTION

S510216A10

- Make sure that all component parts are free of harmful cuts, gouges, and other faults.
- Adjust the teeth alignment. <Ref. to AT-71, ADJUSTMENT, Drive Pinion Shaft.>

## F: ADJUSTMENT SS10216A01

1) Install the oil pump housing assembly to the torque converter clutch case, and secure evenly by tightening four bolts.

### NOTE:

- Thoroughly remove the liquid gasket from the case mating surface beforehand.
- Use an old gasket or an aluminum washer so as not to damage the mating surface of the housing.

### Tightening torque:

**41 N·m (4.2 kgf·m, 30.4 ft·lb)**

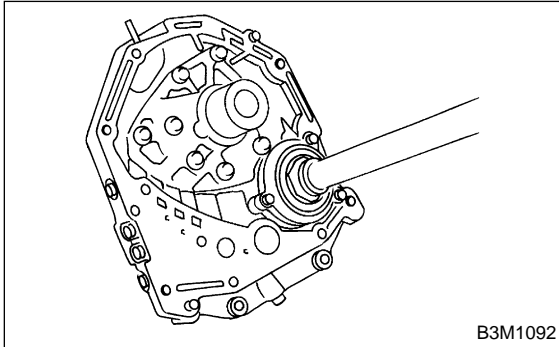

2) Rotate the drive pinion several times with ST1 and ST2.

ST1 498937110 HOLDER  
ST2 499787700 WRENCH

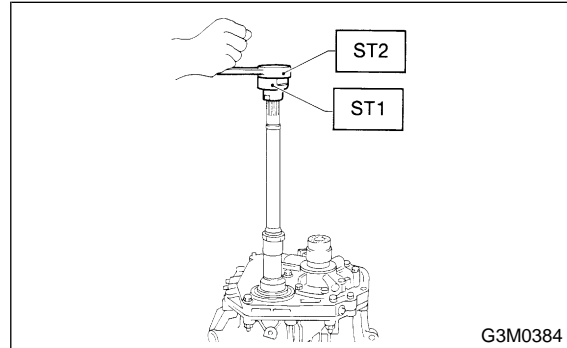



3) Apply red lead evenly to the surfaces of three or four teeth of the crown gear. Rotate the drive pinion in the forward and reverse directions several times. Then remove the oil pump housing, and check the tooth contact pattern.



If tooth contact is improper, readjust the backlash or shim thickness. <Ref. to AT-78, ADJUSTMENT, Front Differential.>

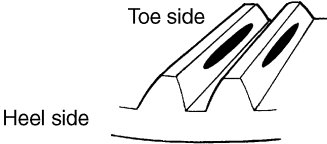
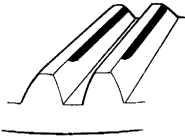
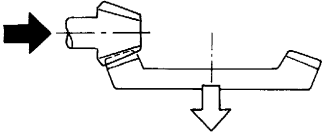
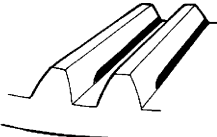
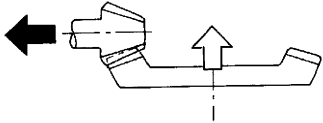
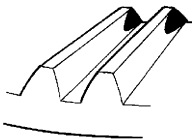
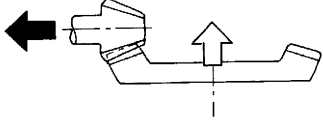

# DRIVE PINION SHAFT

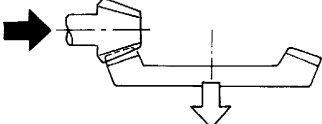
Automatic Transmission

Checking item	Contact pattern	Corrective action
<p>Tooth contact Tooth contact pattern is slightly shifted toward to under no-load rotation. [When loaded, contact pattern moves toward heel.]</p>	 <p>Toe side Heel side B3M0317A</p>	<p>—</p>
<p>Face contact Backlash is too large.</p>	 <p>B3M0319</p>	<p>Increase thickness of drive pinion height adjusting shim in order to bring drive pinion close to crown gear.</p>  <p>B3M0323</p>
<p>Flank contact Backlash is too small.</p>	 <p>B3M0320</p>	<p>Reduce thickness of drive pinion height adjusting shim in order to move drive pinion away from crown gear.</p>  <p>B3M0324</p>
<p>Toe contact (Inside end contact) Contact areas is small.</p>	 <p>B3M0321</p>	<p>Adjust as for flank contact.</p>  <p>B3M0324</p>
<p>Heel contact (Outside end contact) Contact area is small.</p>	 <p>B3M0322</p>	<p>Adjust as for face contact.</p>  <p>B3M0323</p>

 : Adjusting direction of drive pinion  
 : Adjusting direction of crown gear

4) If tooth contact is correct, mark the retainer position and loosen it. After fitting the O-ring, screw in the retainer to the marked position. Then tighten the lock plate to the specified torque.

**Tightening torque:**

**25 N·m (2.5 kgf·m, 18.1 ft·lb)**

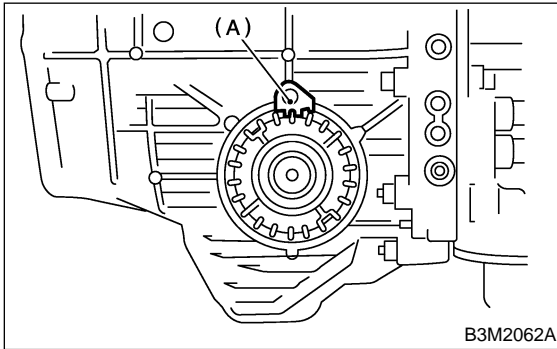

(A) Lock plate

## 19. Drive Pinion Shaft S510216

### A: REMOVAL S510216A18

- 1) Extract the torque converter clutch assembly. <Ref. to AT-35, REMOVAL, Torque Converter Clutch Assembly.>
- 2) Remove the input shaft.

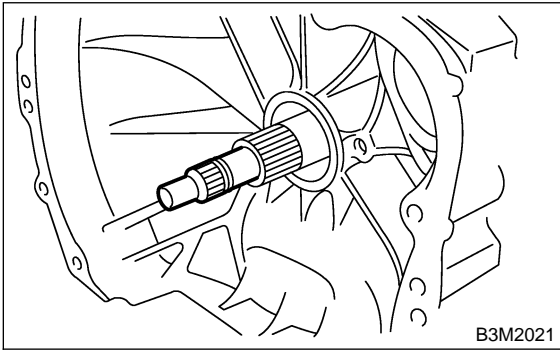

- 3) Disconnect transmission harness connector from stay.

**NOTE:**

Lift-up lever behind the connector and disconnect it from stay.

- 4) Disconnect inhibitor switch connector from stay.
- 5) Disconnect the air breather hose. <Ref. to AT-28, REMOVAL, Air Breather Hose.>
- 6) Remove the oil charger pipe. <Ref. to AT-29, REMOVAL, Oil Charger Pipe.>
- 7) Remove the oil cooler inlet and outlet pipes. <Ref. to AT-30, REMOVAL, Oil Cooler Pipes.>
- 8) Separation of torque converter clutch case and transmission case sections <Ref. to AT-58, REMOVAL, Torque Converter Clutch Case.>
- 9) Separate transmission case and extension case sections. <Ref. to AT-36, REMOVAL, Extension Case.>
- 10) Remove the reduction driven gear.  
Without VTD <Ref. to AT-48, WITHOUT VTD, REMOVAL, Reduction Driven Gear.>  
With VTD <Ref. to AT-48, WITH VTD, REMOVAL, Reduction Driven Gear.>
- 11) Separation of drive pinion shaft and oil pump housing. <Ref. to AT-62, REMOVAL, Oil Pump.>

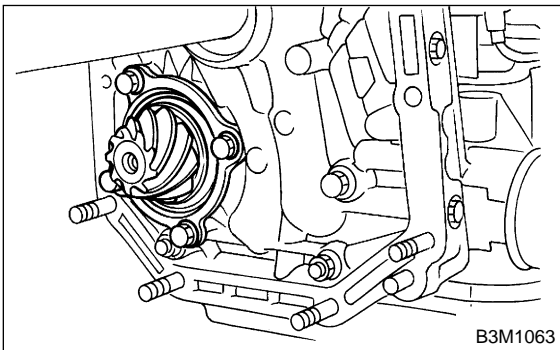

### B: INSTALLATION S510216A11

- 1) Assemble the drive pinion assembly to the oil pump housing. <Ref. to AT-63, INSTALLATION, Oil Pump.>
- 2) Install oil pump housing to transmission case. <Ref. to AT-63, INSTALLATION, Oil Pump.>
- 3) Combine the torque converter case with the transmission case. <Ref. to AT-59, INSTALLATION, Torque Converter Clutch Case.>
- 4) Install the reduction driven gear.  
Without VTD <Ref. to AT-48, WITHOUT VTD, INSTALLATION, Reduction Driven Gear.>  
With VTD <Ref. to AT-49, WITH VTD, INSTALLATION, Reduction Driven Gear.>
- 5) Combine the extension case with the transmission case, and install vehicle speed sensor 1 (rear). <Ref. to AT-36, INSTALLATION, Extension Case.>
- 6) Insert inhibitor switch and transmission connector into stay.
- 7) Install air breather hose. <Ref. to AT-28, INSTALLATION, Air Breather Hose.>
- 8) Install the oil charger pipe with O-ring.
- 9) Insert the input shaft while turning lightly by hand.

**CAUTION:**

Be careful not to damage the bushing.

**Normal protrusion A:**

**50 — 55 mm (1.97 — 2.17 in)**

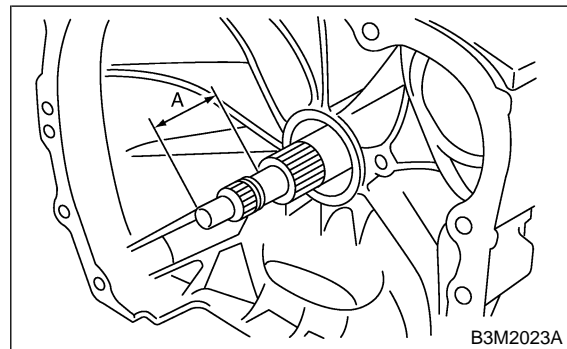

- 10) Install the torque converter clutch assembly. <Ref. to AT-35, INSTALLATION, Torque Converter Clutch Assembly.>

## C: DISASSEMBLY S510216A06

1) Straighten the staked portion of the lock nut, and remove the lock nut while locking the rear spline portion of the shaft with ST1 and ST2. Then pull off the drive pinion collar.

ST1 498937110 HOLDER  
 ST2 499787700 WRENCH  
 ST3 499787500 ADAPTER

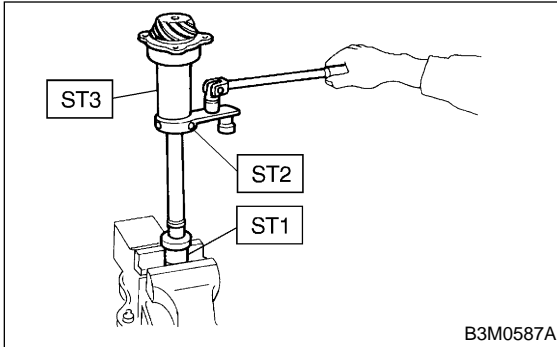

2) Remove the O-ring.  
 3) Using a press, separate the rear roller bearing and outer race from the shaft.

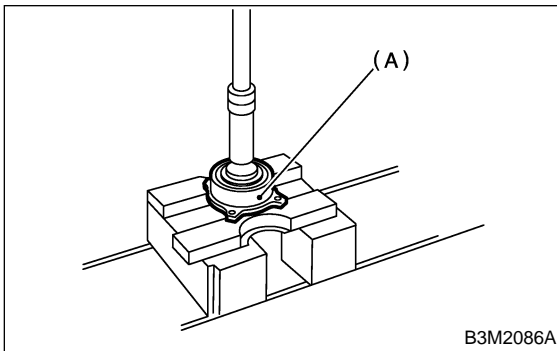

(A) Outer race

4) Using a press and ST, separate the front roller bearing from the shaft.  
 ST 498517000 REPLACER

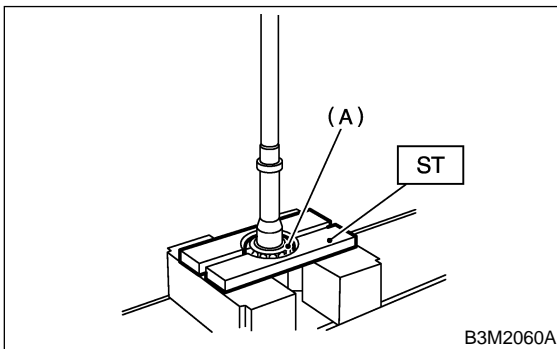

(A) Front roller bearing

## D: ASSEMBLY S510216A02

1) Measure dimension "A" of the drive pinion shaft.

ST 398643600 GAUGE

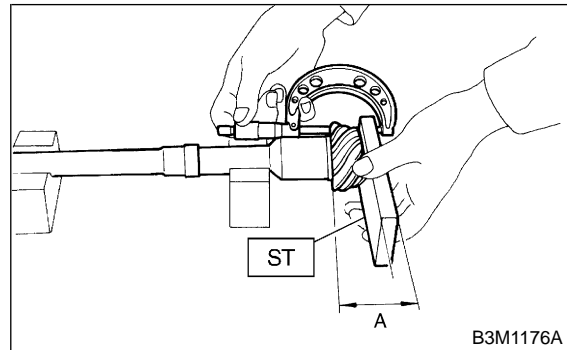

2) Using a press, force-fit the roller bearing in position.

**CAUTION:**  
 Do not change the relative positions of the outer race and bearing cone.

**NOTE:**  
 If too much pressure is applied, the roller bearing will not turn easily.

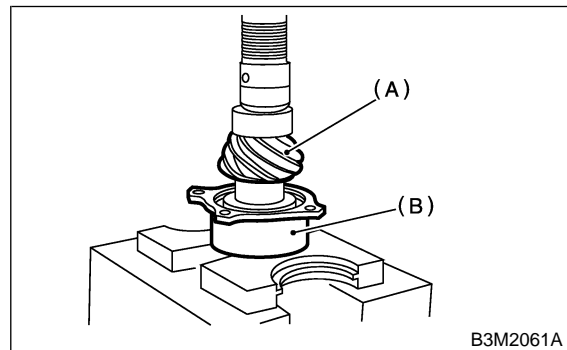

(A) Drive pinion shaft  
 (B) Roller bearing

3) After fitting the O-ring to the shaft, attach the drive pinion collar to the shaft.

**NOTE:**  
 Be careful not to damage the O-ring.

# DRIVE PINION SHAFT

Automatic Transmission

4) Tighten the lock washer and lock nut with ST1, ST2 and ST3.

Calculate lock washer and lock nut specifications using the following formula.

$$T2 = L2 / (L1 + L2) \times T1$$

T1: 116 N·m (11.8 kgf·m, 85.3 ft·lb)

[Required torque setting]

T2: Tightening torque

L1: ST2 length 0.072 m (2.83 in)

L2: Torque wrench length

Example:

Torque wrench length m (in)	Tightening torque N·m (kgf·m, ft·lb)
0.4 (15.75)	98 (10.0, 72)
0.45 (17.72)	100 (10.2, 73.8)
0.5 (19.69)	101 (10.3, 74.5)
0.55 (21.65)	102 (10.4, 75)

ST1 498937110 HOLDER

ST2 499787700 WRENCH

ST3 499787500 ADAPTER

NOTE:

- Pay attention to the orientation of lock washer.
- Install ST2 to torque wrench as straight as possible.

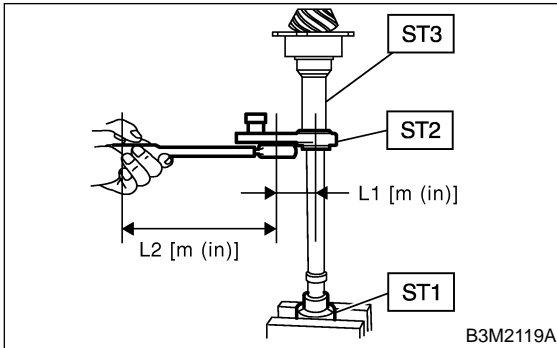

5) Measure the starting torque of the bearing. Make sure the starting torque is within the specified range. If out of the allowable range, replace the roller bearing.

**Starting torque:**

**7.6 — 38.1 N (0.776 — 3.88 kgf, 5.6 — 28.1 ft)**

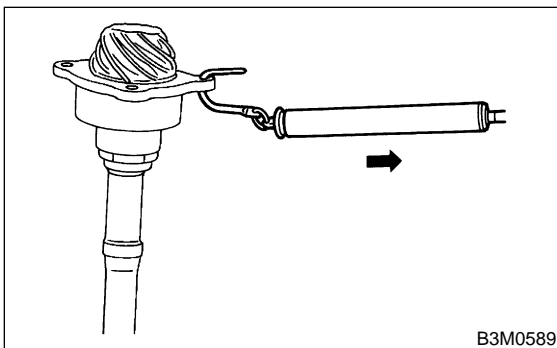

6) Stake the lock nut securely at two places.

7) Measure dimension "B" of the drive pinion shaft.

ST 398643600 GAUGE

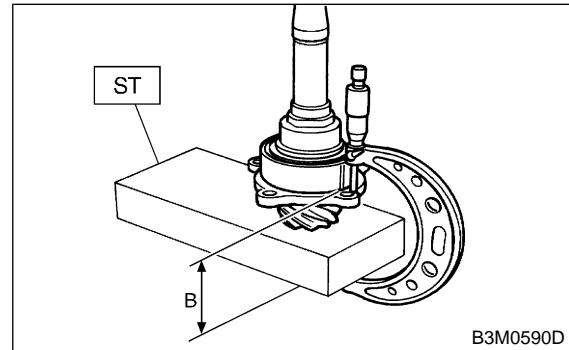

8) Determine the thickness "t" (mm) of the drive pinion shim.

NOTE:

The number of shims must be three or less.

$$t = 6.5 \pm 0.0625 - (B - A)$$

Available drive pinion shims	
Part No.	Thickness mm (in)
31451AA050	0.150 (0.0059)
31451AA060	0.175 (0.0069)
31451AA070	0.200 (0.0079)
31451AA080	0.225 (0.0089)
31451AA090	0.250 (0.0098)
31451AA100	0.275 (0.0108)

## E: INSPECTION

S510216A10

- Make sure that all component parts are free of harmful cuts, gouges, and other faults.
- Adjust the teeth alignment. <Ref. to AT-71, ADJUSTMENT, Drive Pinion Shaft.>

## F: ADJUSTMENT SS10216A01

1) Install the oil pump housing assembly to the torque converter clutch case, and secure evenly by tightening four bolts.

### NOTE:

- Thoroughly remove the liquid gasket from the case mating surface beforehand.
- Use an old gasket or an aluminum washer so as not to damage the mating surface of the housing.

### Tightening torque:

**41 N·m (4.2 kgf-m, 30.4 ft-lb)**

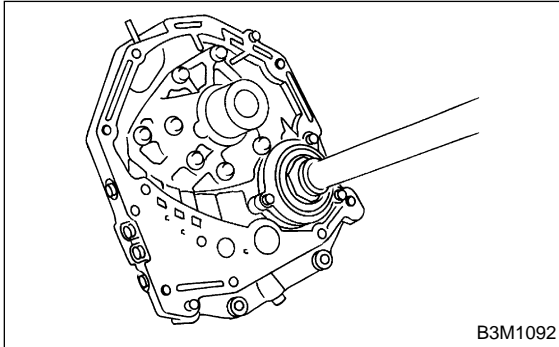

2) Rotate the drive pinion several times with ST1 and ST2.

ST1 498937110 HOLDER  
ST2 499787700 WRENCH

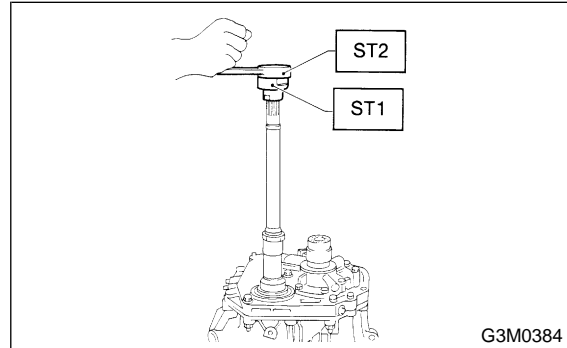





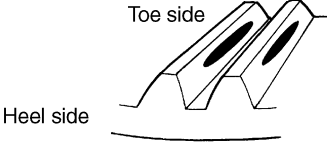

3) Apply red lead evenly to the surfaces of three or four teeth of the crown gear. Rotate the drive pinion in the forward and reverse directions several times. Then remove the oil pump housing, and check the tooth contact pattern.

If tooth contact is improper, readjust the backlash or shim thickness. <Ref. to AT-78, ADJUSTMENT, Front Differential.>

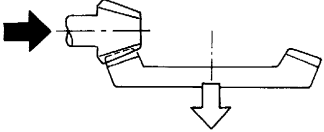
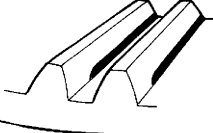
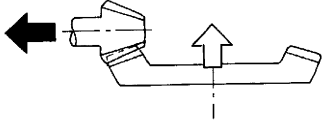
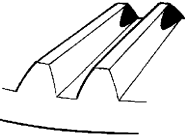
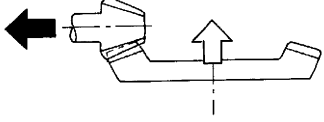
# DRIVE PINION SHAFT

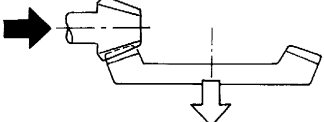
Automatic Transmission

Checking item	Contact pattern	Corrective action
<p>Tooth contact Tooth contact pattern is slightly shifted toward to under no-load rotation. [When loaded, contact pattern moves toward heel.]</p>	 <p style="text-align: center;">B3M0317A</p>	<p style="text-align: center;">—</p>
<p>Face contact Backlash is too large.</p>	 <p style="text-align: center;">B3M0319</p>	<p>Increase thickness of drive pinion height adjusting shim in order to bring drive pinion close to crown gear.</p>  <p style="text-align: right;">B3M0323</p>
<p>Flank contact Backlash is too small.</p>	 <p style="text-align: center;">B3M0320</p>	<p>Reduce thickness of drive pinion height adjusting shim in order to move drive pinion away from crown gear.</p>  <p style="text-align: right;">B3M0324</p>
<p>Toe contact (Inside end contact) Contact areas is small.</p>	 <p style="text-align: center;">B3M0321</p>	<p>Adjust as for flank contact.</p>  <p style="text-align: right;">B3M0324</p>
<p>Heel contact (Outside end contact) Contact area is small.</p>	 <p style="text-align: center;">B3M0322</p>	<p>Adjust as for face contact.</p>  <p style="text-align: right;">B3M0323</p>

 : Adjusting direction of drive pinion  
 : Adjusting direction of crown gear

4) If tooth contact is correct, mark the retainer position and loosen it. After fitting the O-ring, screw in the retainer to the marked position. Then tighten the lock plate to the specified torque.

**Tightening torque:**

**25 N·m (2.5 kgf·m, 18.1 ft·lb)**

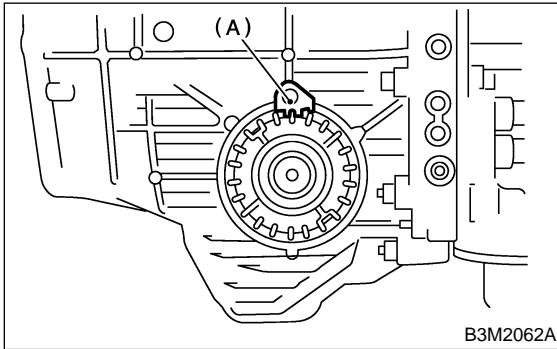

(A) Lock plate



# FRONT DIFFERENTIAL

Automatic Transmission

## 20. Front Differential S510152

### A: REMOVAL S510152A18

- 1) Extract the torque converter clutch assembly. <Ref. to AT-35, REMOVAL, Torque Converter Clutch Assembly.>
- 2) Remove the input shaft.

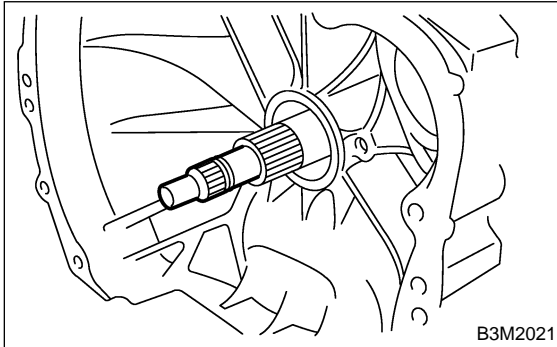

- 3) Disconnect the air breather hose. <Ref. to AT-28, REMOVAL, Air Breather Hose.>
- 4) Disconnect transmission harness connector from stay.

#### NOTE:

Lift-up lever behind the connector and disconnect it from stay.

- 5) Disconnect inhibitor switch from stay.
- 6) Remove the oil charger pipe. <Ref. to AT-29, REMOVAL, Oil Charger Pipe.>
- 7) Remove the oil cooler inlet and outlet pipes. <Ref. to AT-30, REMOVAL, Oil Cooler Pipes.>
- 8) Separation of torque converter clutch case and transmission case. <Ref. to AT-58, REMOVAL, Torque Converter Clutch Case.>
- 9) Wrap the axle shaft serration with vinyl tape.

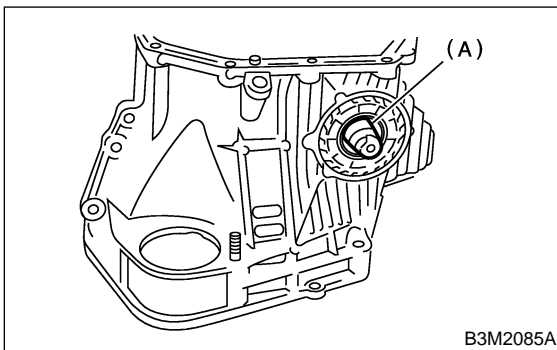

(A) Vinyl tape

- 10) Remove the differential side retainer with ST.

#### NOTE:

Hold the differential case assembly by hand to avoid damaging retainer mounting hole of the torque converter clutch case.

ST 499787000 WRENCH ASSY

- 11) Extract the axle shaft with ST1 and ST2.

#### NOTE:

Do not reuse the circlip.

ST1 499095500 REMOVER  
ST2 499247300 INSTALLER

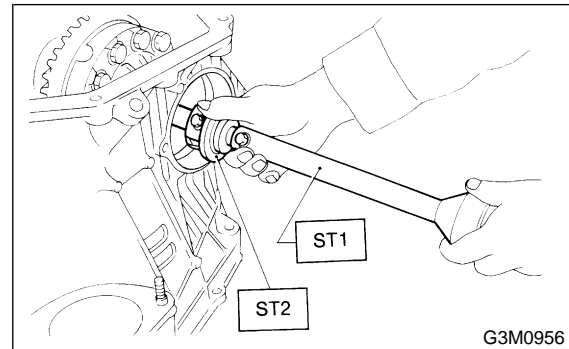

- 12) Remove the differential assembly.

#### NOTE:

- Remove the seal pipe if it is attached. (Reusing is not allowed.)
- Be careful not to damage the retainer mounting hole of the torque converter clutch case.

### B: INSTALLATION S510152A11

- 1) Install the differential assembly to the case, paying special attention not to damage the inside of the case (particularly, the differential side retainer contact surface).

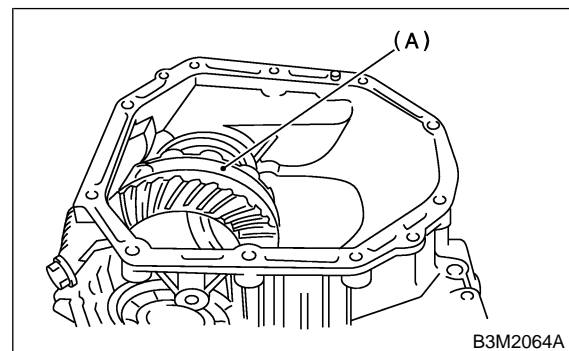

(A) Differential assembly

- 2) Install the new circlip to the axle shaft, insert the shaft into the differential assembly, and tap it into position with a plastic hammer.

#### NOTE:

If no play is felt, check whether the shaft is fully inserted. If shaft insertion is correct, replace the axle shaft.

#### Thrust play:

**0.3 — 0.5 mm (0.012 — 0.020 in)**

- 3) Wrap vinyl tape around the splined portion of the axle shaft.

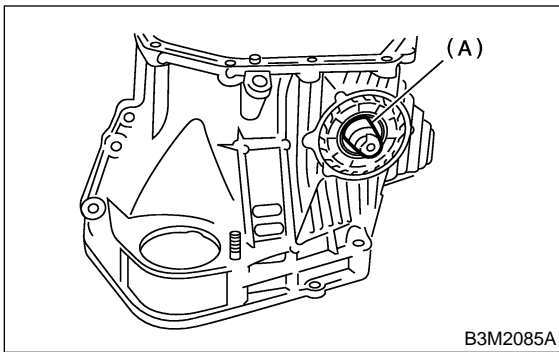

(A) Vinyl tape

4) Install the oil seal and outer race (taper roller bearing) to the differential side retainer. Then screw in the retainer and the O-ring after coating the threads with oil.

**NOTE:**

- Pay attention not to damage the oil seal lips.
- Do not confuse the RH and LH oil seals.
- Keep the O-ring removed from the retainer.

5) Using ST, install the side retainers. <Ref. to AT-74, ADJUSTMENT, Front Differential.>

ST 499787000 WRENCH ASSY

6) Install the lock plate.

**Tightening torque:**

**25 N·m (2.5 kgf-m, 18.1 ft-lb)**

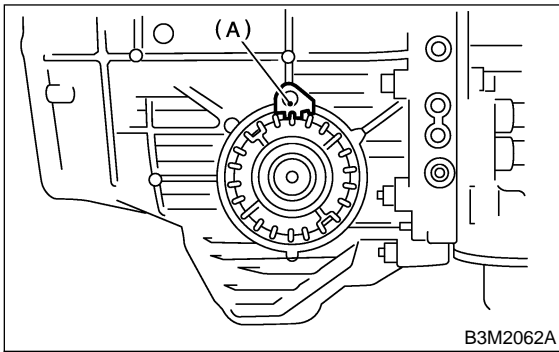

7) Install the new seal pipe to the torque converter clutch case.

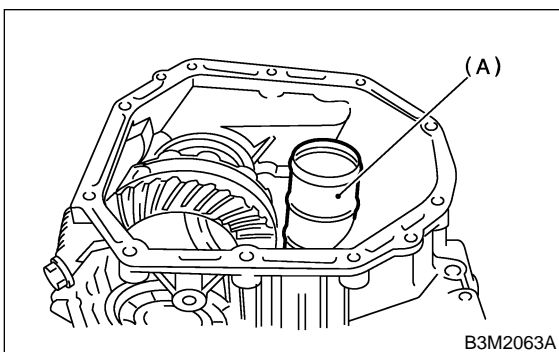

(A) Seal pipe

8) Install the torque converter clutch case to transmission case. <Ref. to AT-59, INSTALLATION, Torque Converter Clutch Case.>

9) Install air breather hose.

10) Insert inhibitor switch and transmission connector into stay.

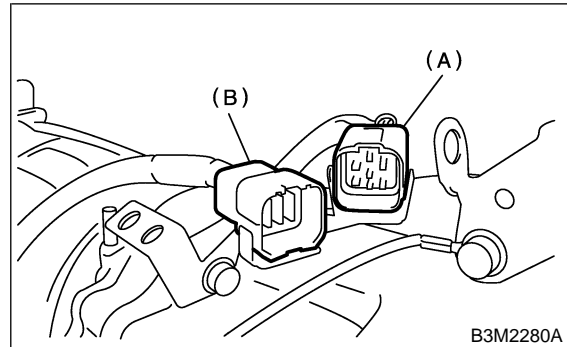

(A) Transmission harness

(B) Inhibitor switch harness

11) Install oil cooler pipes. <Ref. to AT-30, INSTALLATION, Oil Cooler Pipes.>

12) Install the oil charger pipe with O-ring <Ref. to AT-29, INSTALLATION, Oil Charger Pipe.>

13) Insert the input shaft while turning lightly by hand.

**NOTE:**

Be careful not to damage the bushing.

**Normal protrusion A:**

**50 — 55 mm (1.97 — 2.17 in)**

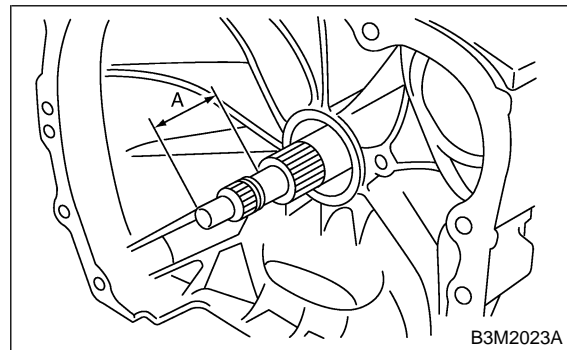

14) Install the torque converter clutch assembly. <Ref. to AT-35, INSTALLATION, Torque Converter Clutch Assembly.>

# FRONT DIFFERENTIAL

Automatic Transmission

## C: DISASSEMBLY S510152A06

### 1. DIFFERENTIAL CASE ASSEMBLY S510152A0601

S510152A0601

1) Using a press and ST, remove the taper roller bearing.

NOTE:

Replacing bearing inner and outer races as a single unit.

ST 498077000 REMOVER

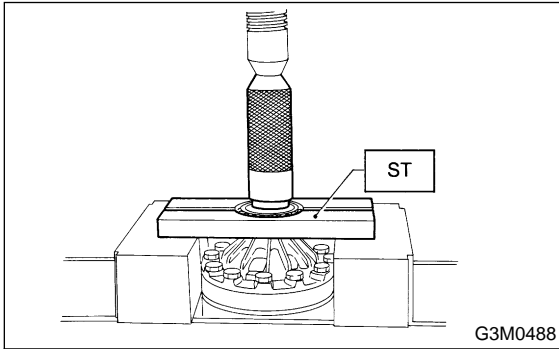

2) Secure the case in a vise and remove the crown gear tightening bolts, then separate the crown gear, case (RH) and case (LH).

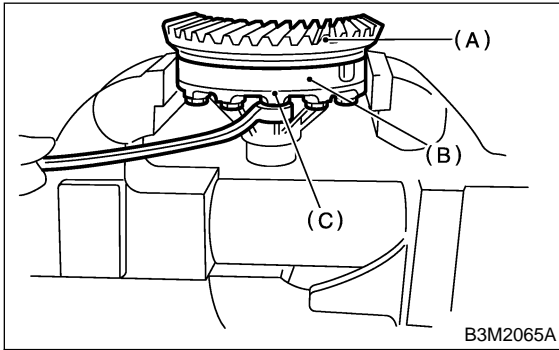

- (A) Crown gear
- (B) Differential case (RH)
- (C) Differential case (LH)

3) Pull out the straight pin and shaft, and remove the differential bevel gear, washer, and differential bevel pinion.

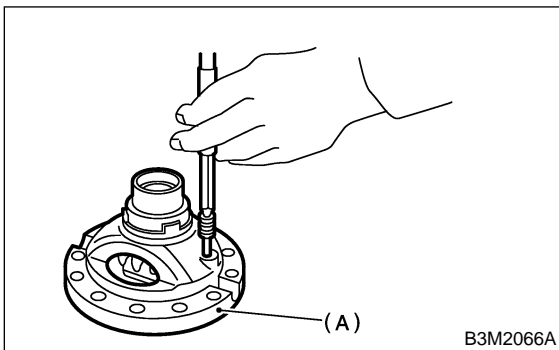

- (A) Differential case (RH)

### 2. SIDE RETAINER S510152A0602

1) Remove O-ring.

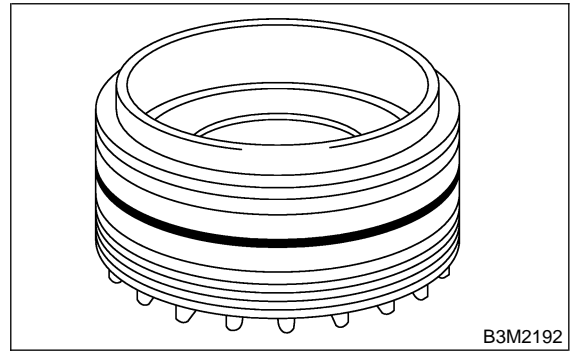

2) Remove oil seal.

NOTE:

Do not re-use oil seal. Prepare a new one.

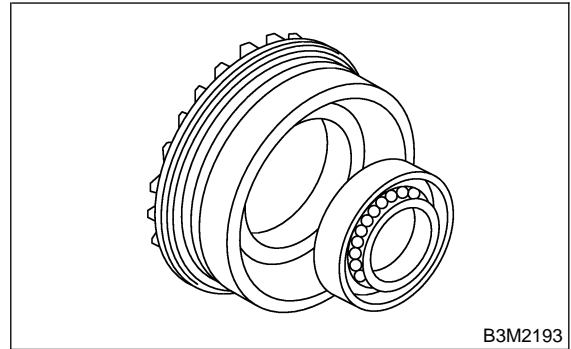

3) Take out either split pin, remove claw.  
ST 398527700 PULLER ASSY

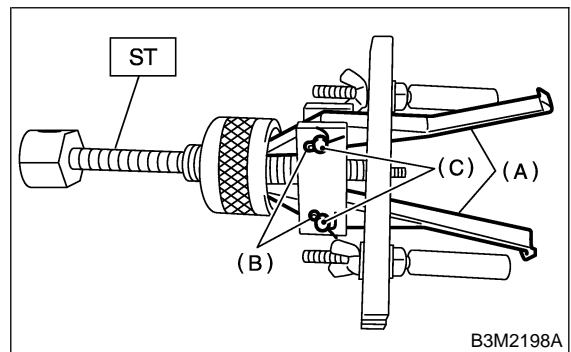

- (A) Claw
- (B) Split pin
- (C) Pin

4) Securely attach two claws to outer race, set ST to side retainer.

ST 398527700 PULLER ASSY

NOTE:

- Attach two shafts' notches to side retainer.
- Return removed claw to the original position, and install pin and split pin.

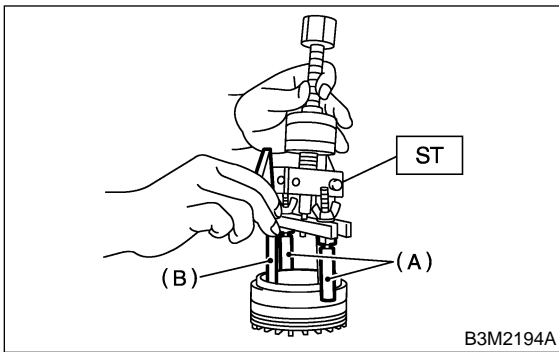

- (A) Shaft
- (B) Claw

5) Remove bearing outer race from side retainer.  
 ST 398527700 PULLER ASSY

**NOTE:**

- Secure ST shaft right up against the side retainer.
- Replace bearing inner and outer races as a single unit.

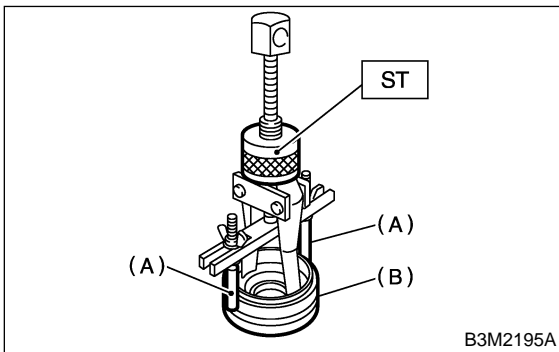

- (A) Shaft
- (B) Side retainer

**D: ASSEMBLY** S510152A02

**1. DIFFERENTIAL CASE ASSEMBLY**

S510152A0201

1) Install the washer, differential bevel gear and differential bevel pinion in the differential case (RH). Insert the pinion shaft, and fit the straight pin.

**NOTE:**

Install straight pin from reverse direction.

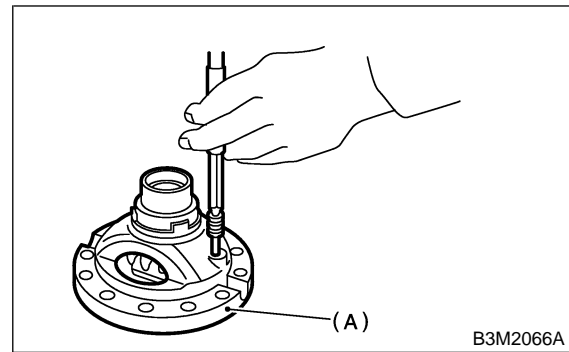

- (A) Differential case (RH)

- 2) Install the washer and differential bevel gear to the differential case (LH). Then put the case over the differential case (RH), and connect both cases.
- 3) Install the crown gear and secure by tightening the bolt.

**Standard tightening torque:**

**62 N·m (6.3 kgf·m, 45.6 ft·lb)**

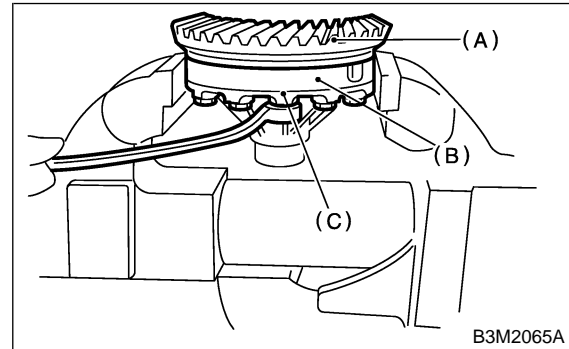

- (A) Crown gear
- (B) Differential case (RH)
- (C) Differential case (LH)

4) Measurement of backlash (Selection of washer)  
 Measure the gear backlash with ST1 and ST2, and insert ST2 through the access window of the case.

ST1 498247001 MAGNET BASE

ST2 498247100 DIAL GAUGE

# FRONT DIFFERENTIAL

Automatic Transmission

## NOTE:

- Measure the backlash by applying a pinion tooth between two bevel gear teeth.
- Fix bevel pinion gear in place with a screwdriver or similar tool when measuring.

## Standard value:

0.13 — 0.18 mm (0.0051 — 0.0071 in)

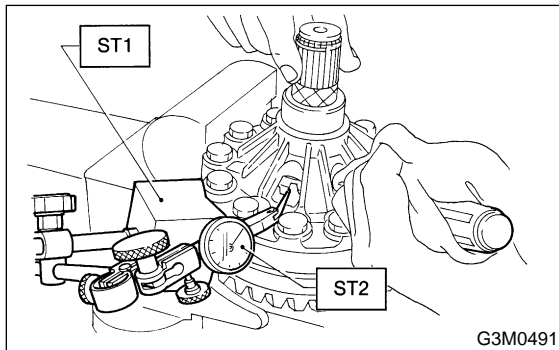

- 5) Using ST, install taper roller bearing.  
ST 398487700 DRIFT

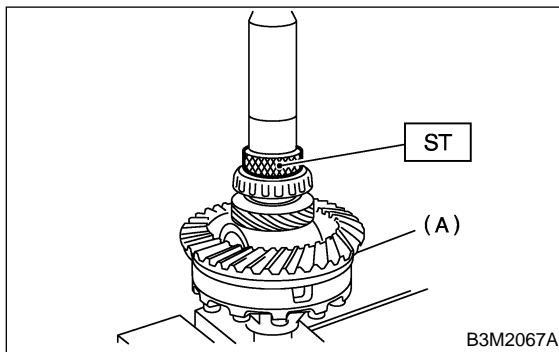

(A) Taper roller bearing

## 2. SIDE RETAINER S510152A020

- 1) Install bearing outer race to side retainer.

## NOTE:

Avoid scratching side retainer and bearing outer race when pressing into place.

- 2) Install new oil seal.

ST 499797000 INSTALLER

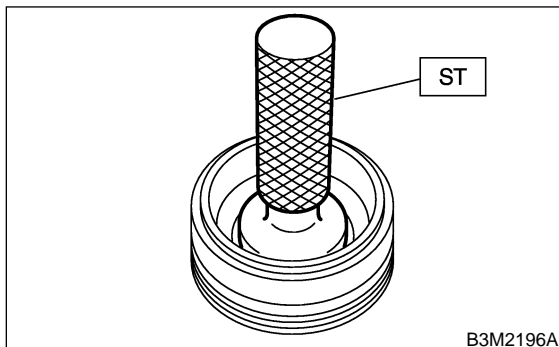

- 3) Install new O-ring.

## NOTE:

Do not stretch or damage O-ring.

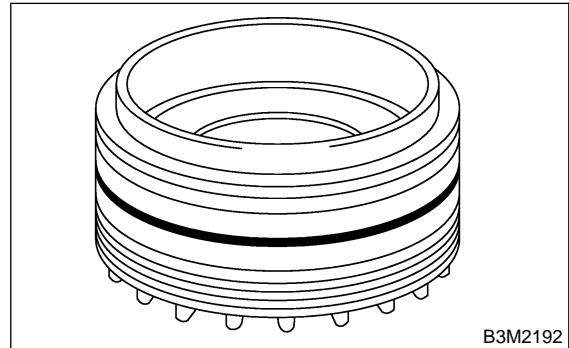

## E: INSPECTION S510152A10

- Check each component for harmful cuts, damage and other faults.
- Measure the backlash and adjust to within specifications.  
<Ref. to AT-78, ADJUSTMENT, Front Differential.>

## F: ADJUSTMENT S510152A01

- 1) Using ST, screw in the retainer until light contact is felt.

## NOTE:

Screw in the RH side slightly deeper than the LH side.

ST 499787000 WRENCH ASSY

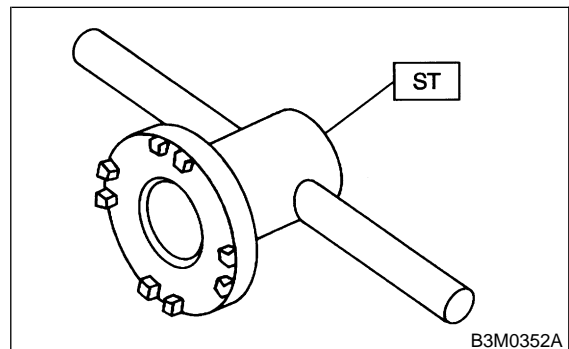

- 2) Remove the oil pump housing.  
3) Install the oil pump housing assembly to the torque converter clutch case, and secure evenly by tightening four bolts.

# FRONT DIFFERENTIAL

Automatic Transmission

## NOTE:

- Thoroughly remove the liquid gasket from the case mating surface beforehand.
- Use an old gasket or an aluminum washer so as not to damage the mating surface of the housing.

## Tightening torque:

**41 N·m (4.2 kgf·m, 30.4 ft·lb)**

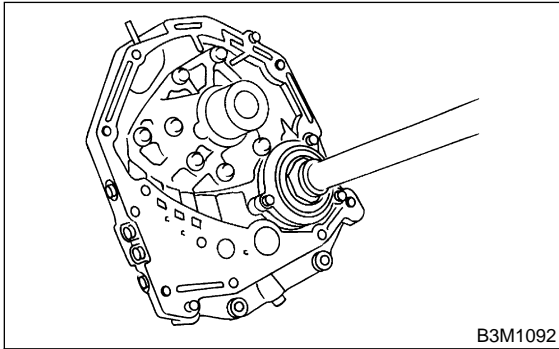

4) Rotate the drive pinion several times with ST1 and ST2.

ST1 498937110 HOLDER  
ST2 499787700 WRENCH

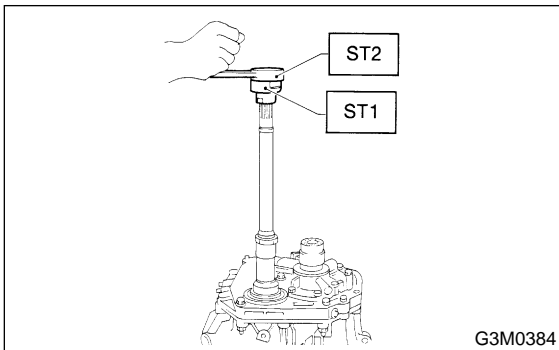

5) Tighten the LH retainer until contact is felt while rotating the shaft. Then loosen the RH retainer. Keep tightening the LH retainer and loosening the RH retainer until the pinion shaft can no longer be turned. This is the “zero” state.

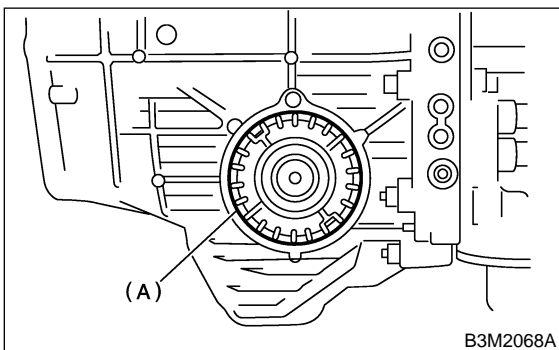

(A) Retainer

6) After the “zero” state is established, back off the LH retainer 3 notches and secure it with the lock plate. Then back off the RH retainer and retighten until it stops. Rotate drive pinion a few times. Tighten the RH retainer 1-3/4 notches further. This sets the preload. Finally, secure the retainer with its lock plate.

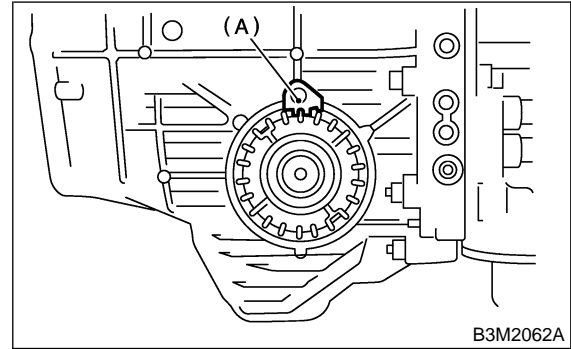

(A) Lock plate

## NOTE:

Turning the retainer by one tooth changes the backlash about 0.05 mm (0.0020 in).

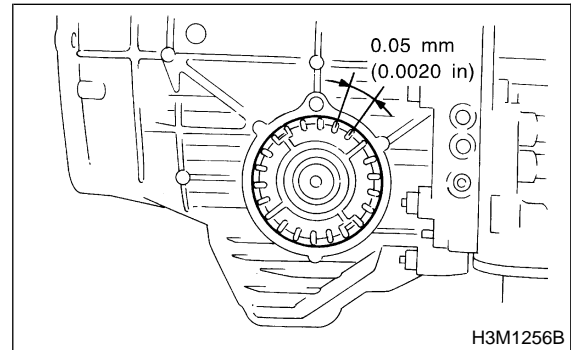

# FRONT DIFFERENTIAL

Automatic Transmission

---

7) Turn the drive pinion several rotations with ST1 and check to see if the backlash is within the standard value with ST2, ST3, ST4 and ST5.

**NOTE:**

After confirming that the backlash is correct, check the tooth contact.

ST1	499787700	WRENCH
ST2	498247001	MAGNET BASE
ST3	498247100	DIAL GAUGE
ST4	499787500	ADAPTER
ST5	498255400	PLATE

**Backlash:**

**0.13 — 0.18 mm (0.0051 — 0.0071 in)**

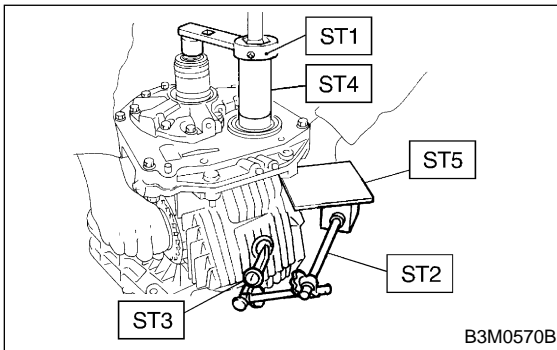

# FRONT DIFFERENTIAL

Automatic Transmission

## 20. Front Differential S510152

### A: REMOVAL S510152A18

- 1) Extract the torque converter clutch assembly. <Ref. to AT-35, REMOVAL, Torque Converter Clutch Assembly.>
- 2) Remove the input shaft.

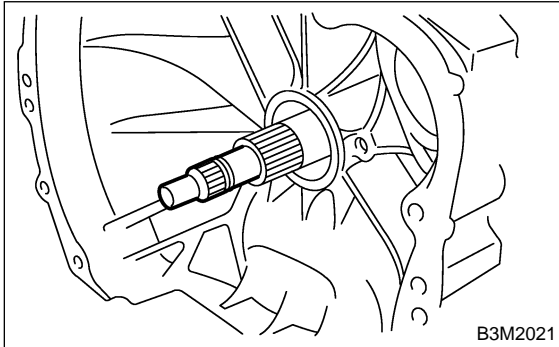

- 3) Disconnect the air breather hose. <Ref. to AT-28, REMOVAL, Air Breather Hose.>
- 4) Disconnect transmission harness connector from stay.

#### NOTE:

Lift-up lever behind the connector and disconnect it from stay.

- 5) Disconnect inhibitor switch from stay.
- 6) Remove the oil charger pipe. <Ref. to AT-29, REMOVAL, Oil Charger Pipe.>
- 7) Remove the oil cooler inlet and outlet pipes. <Ref. to AT-30, REMOVAL, Oil Cooler Pipes.>
- 8) Separation of torque converter clutch case and transmission case. <Ref. to AT-58, REMOVAL, Torque Converter Clutch Case.>
- 9) Wrap the axle shaft serration with vinyl tape.

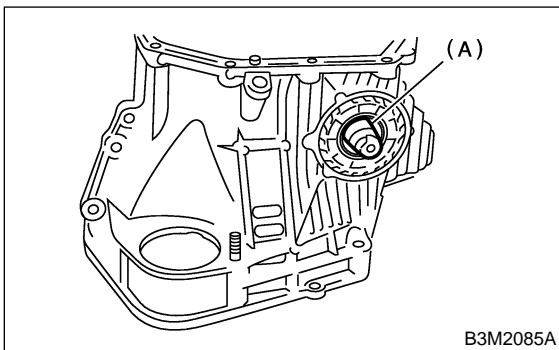

(A) Vinyl tape

- 10) Remove the differential side retainer with ST.

#### NOTE:

Hold the differential case assembly by hand to avoid damaging retainer mounting hole of the torque converter clutch case.

ST 499787000 WRENCH ASSY

- 11) Extract the axle shaft with ST1 and ST2.

#### NOTE:

Do not reuse the circlip.

ST1 499095500 REMOVER  
ST2 499247300 INSTALLER

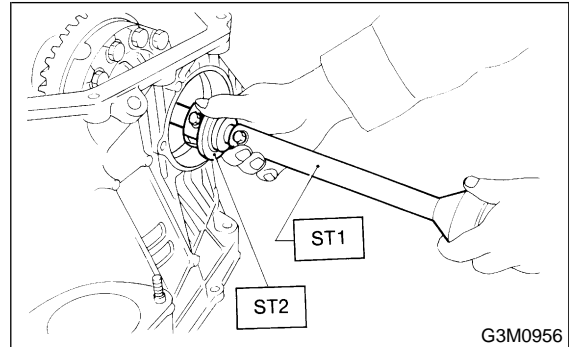

- 12) Remove the differential assembly.

#### NOTE:

- Remove the seal pipe if it is attached. (Reusing is not allowed.)
- Be careful not to damage the retainer mounting hole of the torque converter clutch case.

### B: INSTALLATION S510152A11

- 1) Install the differential assembly to the case, paying special attention not to damage the inside of the case (particularly, the differential side retainer contact surface).

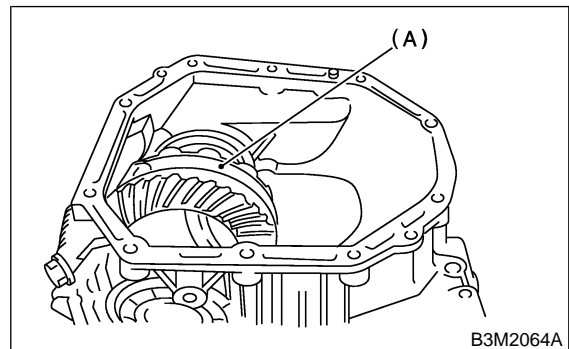

(A) Differential assembly

- 2) Install the new circlip to the axle shaft, insert the shaft into the differential assembly, and tap it into position with a plastic hammer.

#### NOTE:

If no play is felt, check whether the shaft is fully inserted. If shaft insertion is correct, replace the axle shaft.

#### Thrust play:

**0.3 — 0.5 mm (0.012 — 0.020 in)**

- 3) Wrap vinyl tape around the splined portion of the axle shaft.



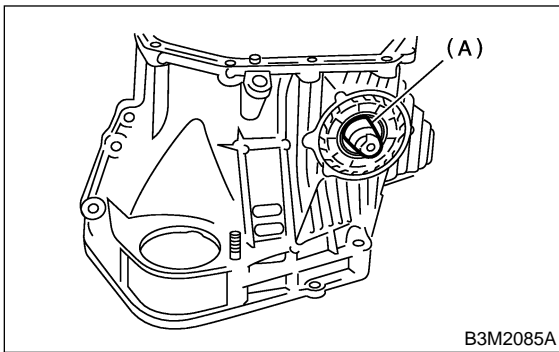

(A) Vinyl tape

4) Install the oil seal and outer race (taper roller bearing) to the differential side retainer. Then screw in the retainer and the O-ring after coating the threads with oil.

**NOTE:**

- Pay attention not to damage the oil seal lips.
- Do not confuse the RH and LH oil seals.
- Keep the O-ring removed from the retainer.

5) Using ST, install the side retainers. <Ref. to AT-74, ADJUSTMENT, Front Differential.>

ST 499787000 WRENCH ASSY

6) Install the lock plate.

**Tightening torque:**

**25 N·m (2.5 kgf-m, 18.1 ft-lb)**

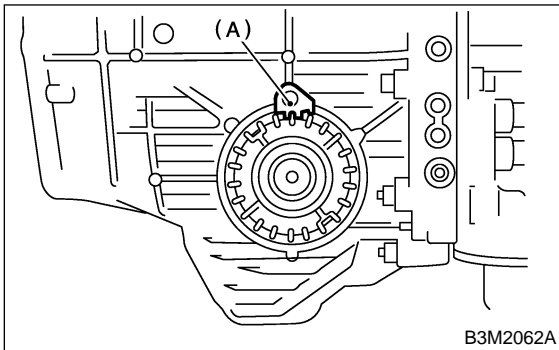

7) Install the new seal pipe to the torque converter clutch case.

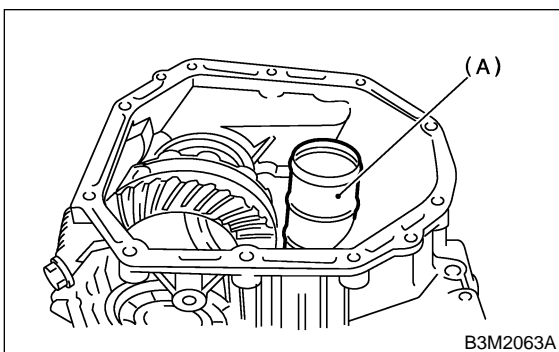

(A) Seal pipe

8) Install the torque converter clutch case to transmission case. <Ref. to AT-59, INSTALLATION, Torque Converter Clutch Case.>

9) Install air breather hose.

10) Insert inhibitor switch and transmission connector into stay.

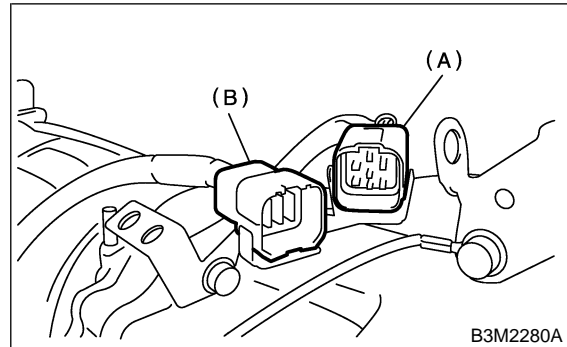

(A) Transmission harness

(B) Inhibitor switch harness

11) Install oil cooler pipes. <Ref. to AT-30, INSTALLATION, Oil Cooler Pipes.>

12) Install the oil charger pipe with O-ring <Ref. to AT-29, INSTALLATION, Oil Charger Pipe.>

13) Insert the input shaft while turning lightly by hand.

**NOTE:**

Be careful not to damage the bushing.

**Normal protrusion A:**

**50 — 55 mm (1.97 — 2.17 in)**

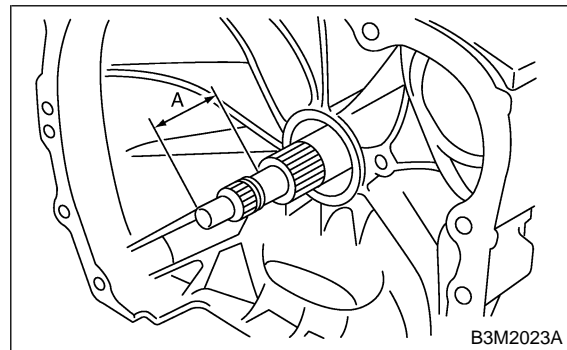

14) Install the torque converter clutch assembly. <Ref. to AT-35, INSTALLATION, Torque Converter Clutch Assembly.>

# FRONT DIFFERENTIAL

Automatic Transmission

## C: DISASSEMBLY S510152A06

### 1. DIFFERENTIAL CASE ASSEMBLY S510152A0601

S510152A0601

1) Using a press and ST, remove the taper roller bearing.

NOTE:

Replacing bearing inner and outer races as a single unit.

ST 498077000 REMOVER

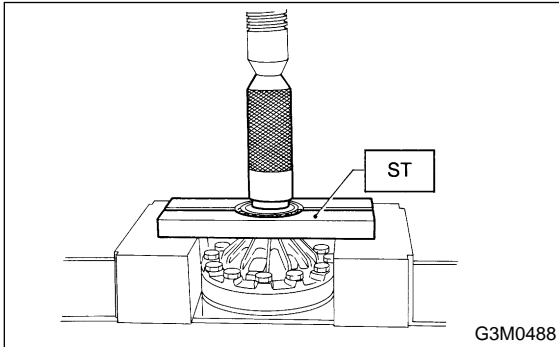

2) Secure the case in a vise and remove the crown gear tightening bolts, then separate the crown gear, case (RH) and case (LH).

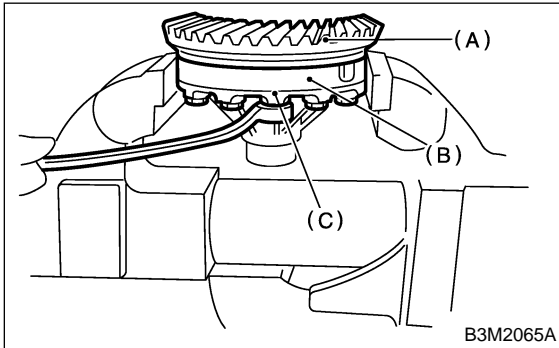

- (A) Crown gear
- (B) Differential case (RH)
- (C) Differential case (LH)

3) Pull out the straight pin and shaft, and remove the differential bevel gear, washer, and differential bevel pinion.

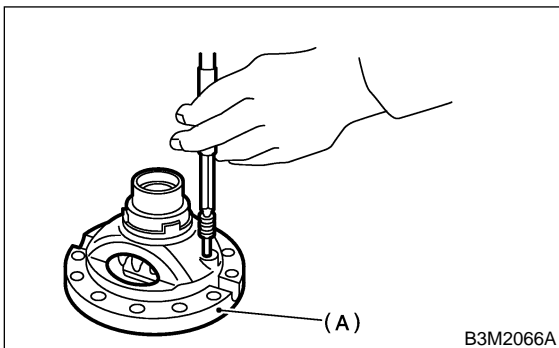

- (A) Differential case (RH)

### 2. SIDE RETAINER S510152A0602

1) Remove O-ring.

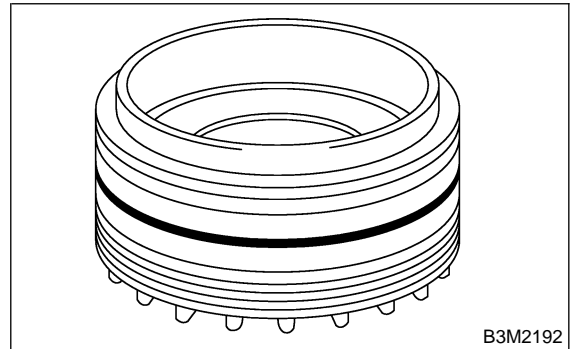

2) Remove oil seal.

NOTE:

Do not re-use oil seal. Prepare a new one.

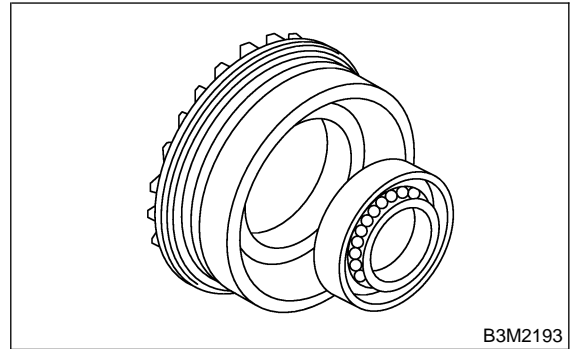

3) Take out either split pin, remove claw.  
ST 398527700 PULLER ASSY

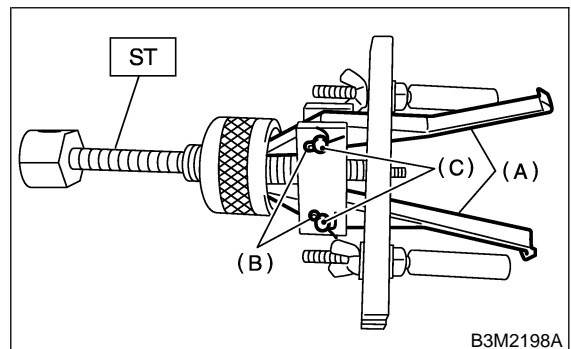

- (A) Claw
- (B) Split pin
- (C) Pin

4) Securely attach two claws to outer race, set ST to side retainer.

ST 398527700 PULLER ASSY

NOTE:

- Attach two shafts' notches to side retainer.
- Return removed claw to the original position, and install pin and split pin.

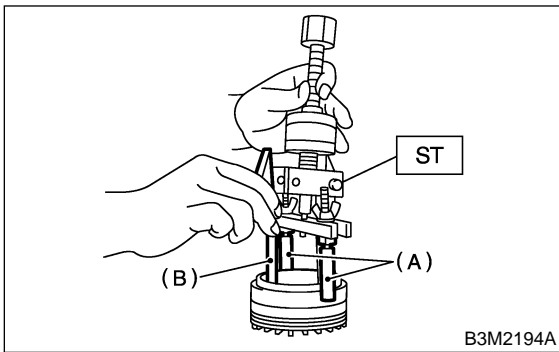

- (A) Shaft
- (B) Claw

5) Remove bearing outer race from side retainer.  
 ST 398527700 PULLER ASSY

**NOTE:**

- Secure ST shaft right up against the side retainer.
- Replace bearing inner and outer races as a single unit.

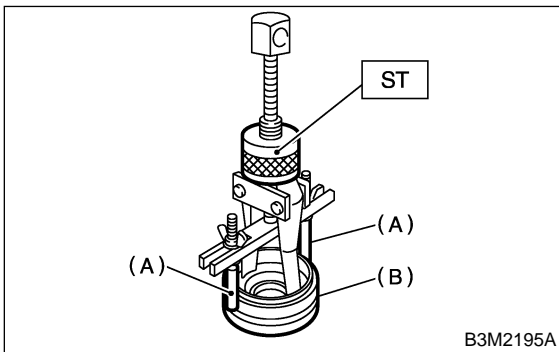

- (A) Shaft
- (B) Side retainer

**D: ASSEMBLY** S510152A02

**1. DIFFERENTIAL CASE ASSEMBLY**

S510152A0201

1) Install the washer, differential bevel gear and differential bevel pinion in the differential case (RH). Insert the pinion shaft, and fit the straight pin.

**NOTE:**

Install straight pin from reverse direction.

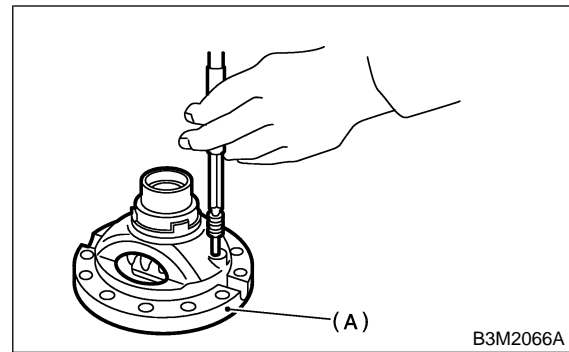

- (A) Differential case (RH)

- 2) Install the washer and differential bevel gear to the differential case (LH). Then put the case over the differential case (RH), and connect both cases.
- 3) Install the crown gear and secure by tightening the bolt.

**Standard tightening torque:**

**62 N·m (6.3 kgf·m, 45.6 ft·lb)**

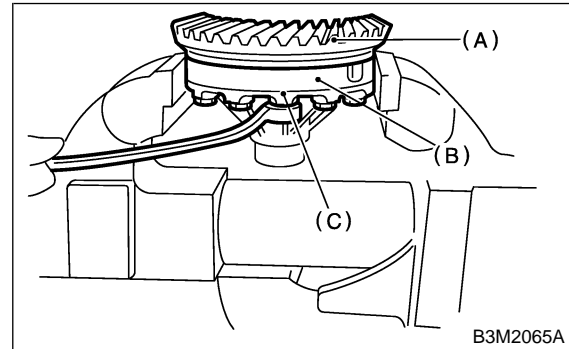

- (A) Crown gear
- (B) Differential case (RH)
- (C) Differential case (LH)

4) Measurement of backlash (Selection of washer)  
 Measure the gear backlash with ST1 and ST2, and insert ST2 through the access window of the case.

ST1 498247001 MAGNET BASE

ST2 498247100 DIAL GAUGE

# FRONT DIFFERENTIAL

Automatic Transmission

## NOTE:

- Measure the backlash by applying a pinion tooth between two bevel gear teeth.
- Fix bevel pinion gear in place with a screwdriver or similar tool when measuring.

## Standard value:

0.13 — 0.18 mm (0.0051 — 0.0071 in)

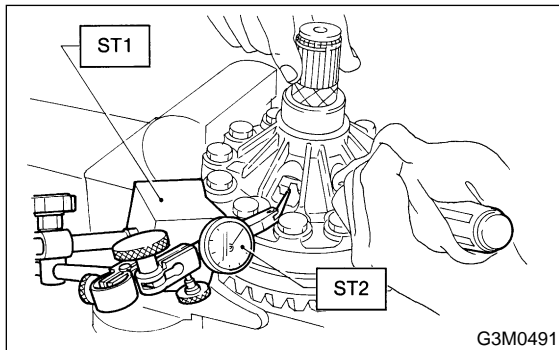

- 5) Using ST, install taper roller bearing.  
ST 398487700 DRIFT

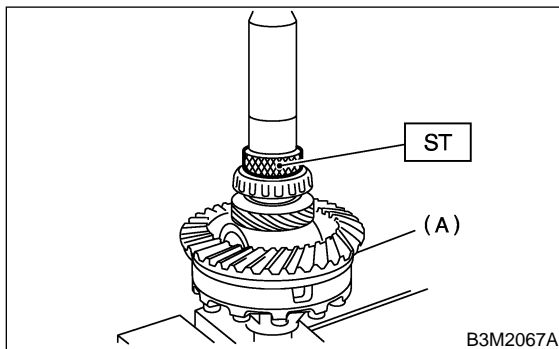

(A) Taper roller bearing

## 2. SIDE RETAINER S510152A020

- 1) Install bearing outer race to side retainer.

## NOTE:

Avoid scratching side retainer and bearing outer race when pressing into place.

- 2) Install new oil seal.

ST 499797000 INSTALLER

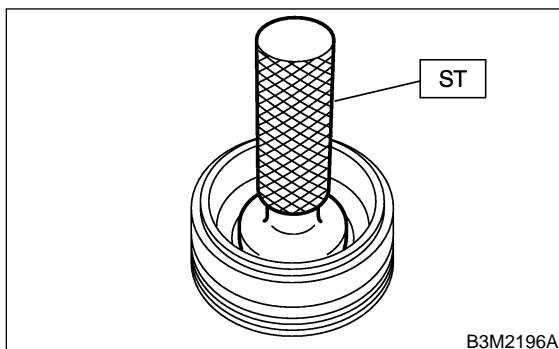

- 3) Install new O-ring.

## NOTE:

Do not stretch or damage O-ring.

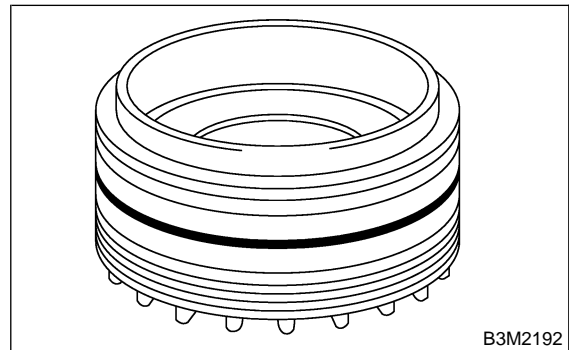

## E: INSPECTION S510152A10

- Check each component for harmful cuts, damage and other faults.
  - Measure the backlash and adjust to within specifications.
- <Ref. to AT-78, ADJUSTMENT, Front Differential.>

## F: ADJUSTMENT S510152A01

- 1) Using ST, screw in the retainer until light contact is felt.

## NOTE:

Screw in the RH side slightly deeper than the LH side.

ST 499787000 WRENCH ASSY

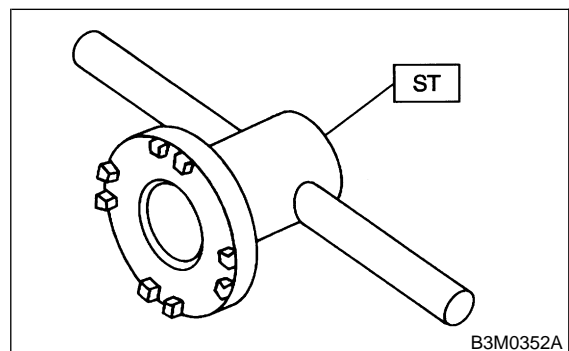

- 2) Remove the oil pump housing.  
3) Install the oil pump housing assembly to the torque converter clutch case, and secure evenly by tightening four bolts.

**NOTE:**

- Thoroughly remove the liquid gasket from the case mating surface beforehand.
- Use an old gasket or an aluminum washer so as not to damage the mating surface of the housing.

**Tightening torque:**

**41 N·m (4.2 kgf·m, 30.4 ft·lb)**

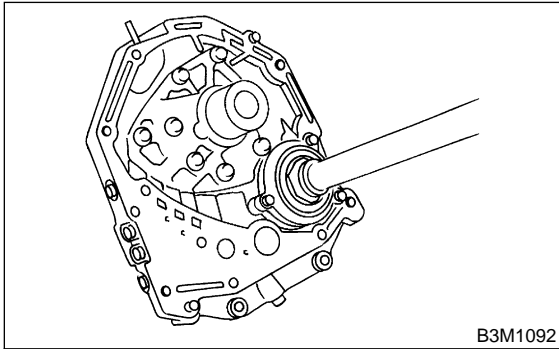

4) Rotate the drive pinion several times with ST1 and ST2.

ST1 498937110 HOLDER  
ST2 499787700 WRENCH

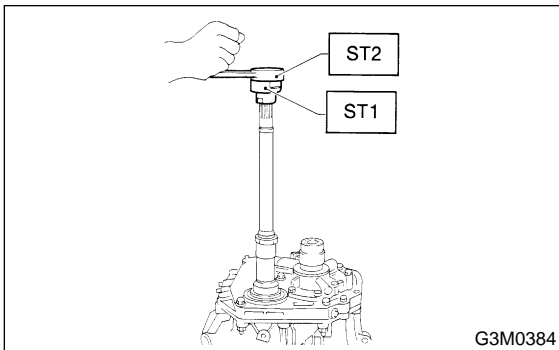

5) Tighten the LH retainer until contact is felt while rotating the shaft. Then loosen the RH retainer. Keep tightening the LH retainer and loosening the RH retainer until the pinion shaft can no longer be turned. This is the “zero” state.

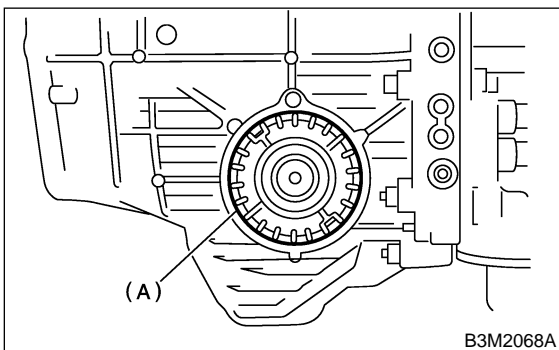

(A) Retainer

6) After the “zero” state is established, back off the LH retainer 3 notches and secure it with the lock plate. Then back off the RH retainer and retighten until it stops. Rotate drive pinion a few times. Tighten the RH retainer 1-3/4 notches further. This sets the preload. Finally, secure the retainer with its lock plate.

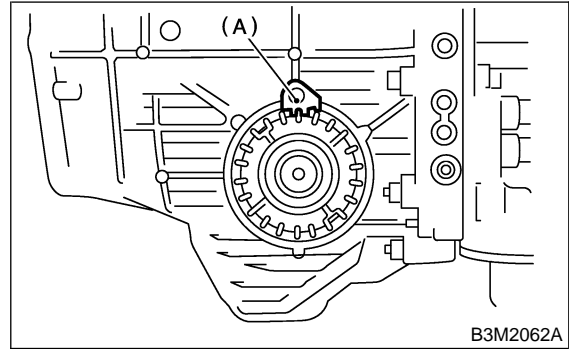

(A) Lock plate

**NOTE:**

Turning the retainer by one tooth changes the backlash about 0.05 mm (0.0020 in).

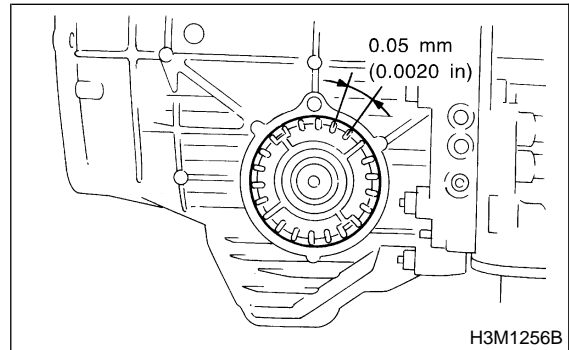

# FRONT DIFFERENTIAL

Automatic Transmission

---

7) Turn the drive pinion several rotations with ST1 and check to see if the backlash is within the standard value with ST2, ST3, ST4 and ST5.

**NOTE:**

After confirming that the backlash is correct, check the tooth contact.

ST1	499787700	WRENCH
ST2	498247001	MAGNET BASE
ST3	498247100	DIAL GAUGE
ST4	499787500	ADAPTER
ST5	498255400	PLATE

**Backlash:**

***0.13 — 0.18 mm (0.0051 — 0.0071 in)***

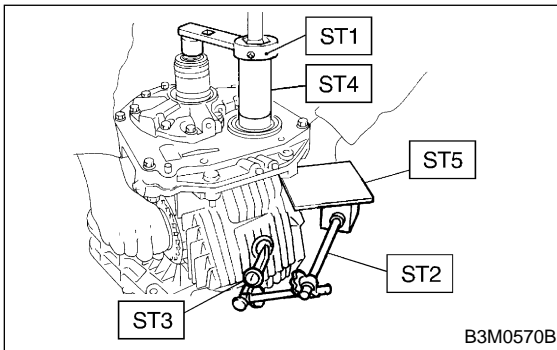

## 21. Control Valve Body Assembly

S510593

### A: REMOVAL

S510593A18

- 1) Extract the torque converter clutch assembly. <Ref. to AT-35, REMOVAL, Torque Converter Clutch Assembly.>
- 2) Remove the input shaft.

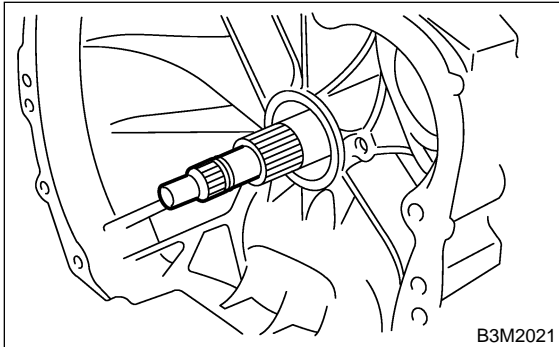

- 3) Disconnect the air breather hose. <Ref. to AT-28, REMOVAL, Air Breather Hose.>
- 4) Disconnect transmission harness connector from stay.

**NOTE:**

Lift-up lever behind the connector and disconnect it from stay.

- 5) Disconnect inhibitor switch from stay.
- 6) Remove the oil charger pipe. <Ref. to AT-29, REMOVAL, Oil Charger Pipe.>
- 7) To plug the hole, wrap vinyl tape around the nipple attached to the air breather hose.
- 8) Remove pitching stopper bracket.
- 9) Remove the inhibitor switch.

**NOTE:**

For removal procedures of inhibitor switch, refer to "AT" sections for each model.

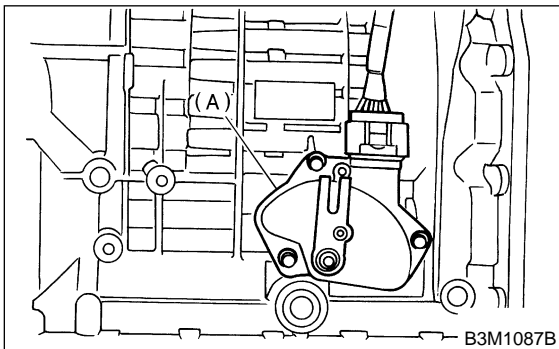

(A) Inhibitor switch

- 10) Prepare a block of wood. Turn the transmission case over, and support it with the block of wood.

**NOTE:**

Turn the transmission case in the direction the inhibitor switch was installed.

- 11) Remove the oil pan.

**NOTE:**

Use a scraper to remove oil pan.

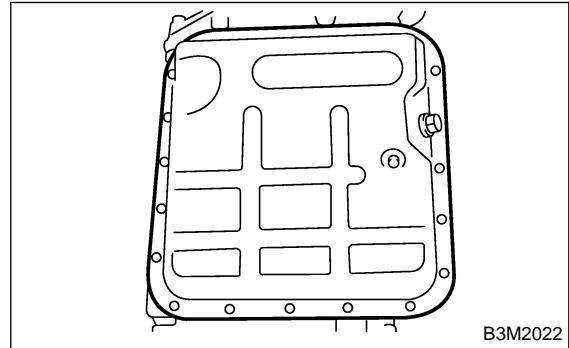

- 12) Disconnect the harness connectors for the solenoids, duty solenoids, ATF temperature sensor and the ground cord.

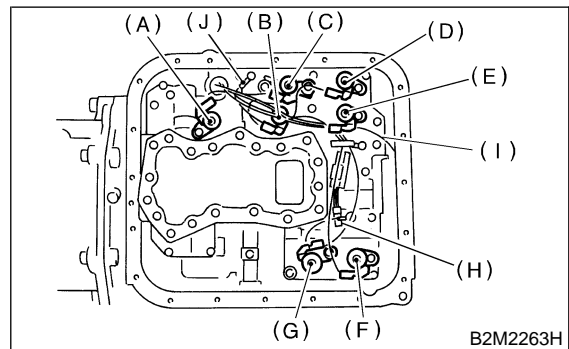

- (A) Lock-up duty solenoid (Blue)
- (B) Low clutch timing solenoid (Gray)
- (C) Line pressure duty solenoid (Red)
- (D) Shift solenoid 2 (Yellow)
- (E) Shift solenoid 1 (Green)
- (F) 2-4 brake timing solenoid (Black)
- (G) 2-4 brake duty solenoid (Red)
- (H) ATF temperature sensor
- (I) Transfer duty solenoid (Brown)
- (J) Transmission ground

- 13) Remove the control valve body assembly.

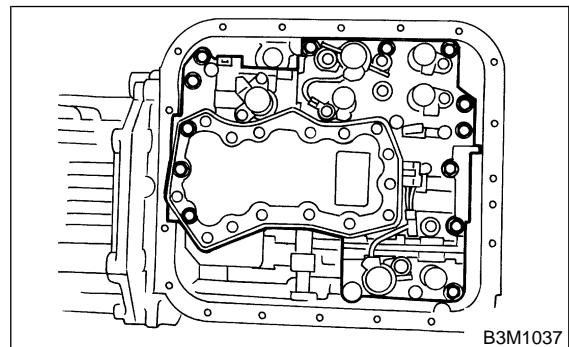

# CONTROL VALVE BODY ASSEMBLY

Automatic Transmission

## B: INSTALLATION S510593A11

- 1) Set the select lever in range "N".
- 2) Align the groove of the manual valve to the protrusion of the manual lever, and then install the control valve body assembly.

**Tightening torque:**  
**8 N·m (0.8 kgf-m, 5.8 ft-lb)**

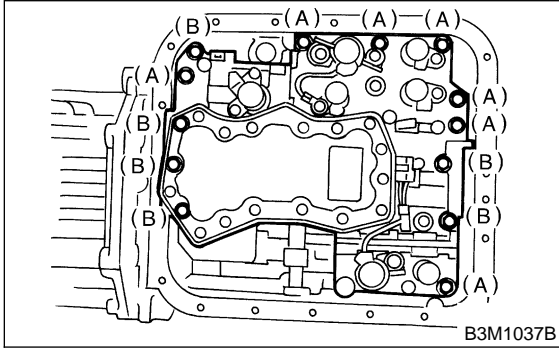

- (A) Short bolts
- (B) Long bolts

- 3) Tighten the valve body to the specified torque.

**NOTE:**  
 Tighten the control valve mounting bolts evenly.

**Tightening torque:**  
**8 N·m (0.8 kgf-m, 5.8 ft-lb)**

- 4) Connect all connectors.

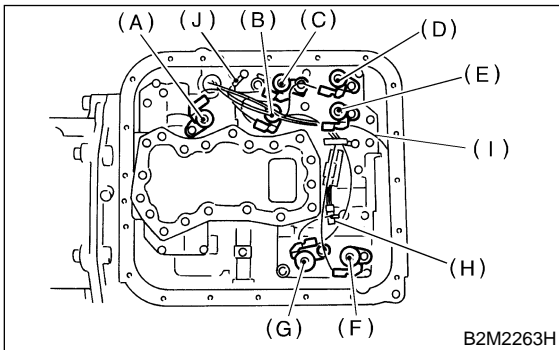

- (A) Lock-up duty solenoid (Blue)
- (B) Low clutch timing solenoid (Gray)
- (C) Line pressure duty solenoid (Red)
- (D) Shift solenoid 2 (Yellow)
- (E) Shift solenoid 1 (Green)
- (F) 2-4 brake timing solenoid (Black)
- (G) 2-4 brake duty solenoid (Red)
- (H) ATF temperature sensor
- (I) Transfer duty solenoid (Brown)
- (J) Transmission ground

- 5) Attach the magnet at the specified position.

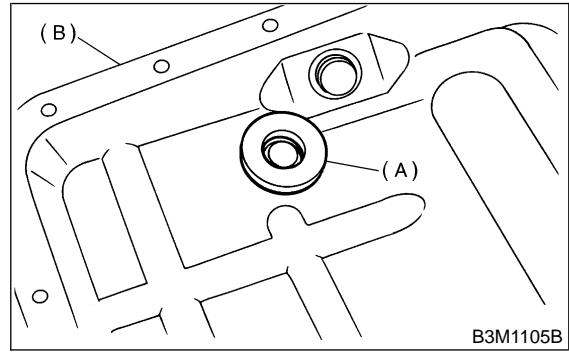

- (A) Magnet
- (B) Oil pan

- 6) Apply proper amount of liquid gasket to the entire oil pan mating surface.

**Liquid gasket:**  
**THREE BOND 1217B**

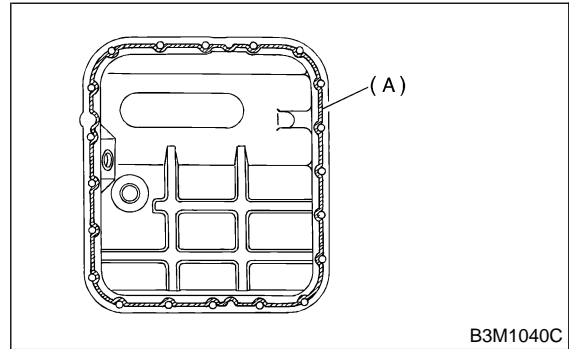

- (A) THREE BOND (Part No. 1217B)

- 7) Besides bolt hole on transmission side, completely fill in liquid gasket at three holes.

**Fluid packing:**  
**THREE BOND 1217B**

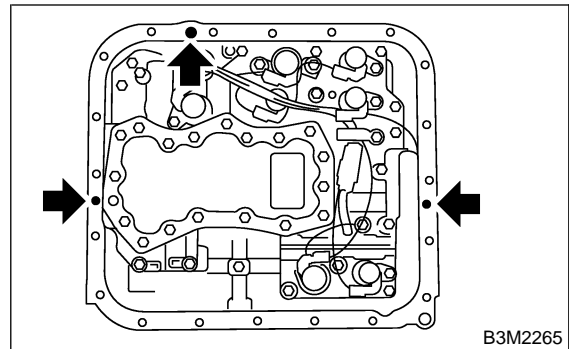



8) Install the oil pan to the transmission case assembly.

**NOTE:**

Tighten the bolts evenly.

**Tightening torque:**

**5 N·m (0.50 kgf-m, 3.6 ft-lb)**

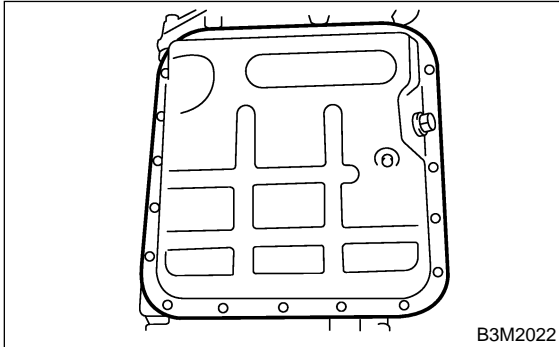

9) Turn over the transmission case to its original position.

10) Install inhibitor switch and adjust the inhibitor switch by referring to Supplement AT section.

11) Install air breather hose. <Ref. to AT-28, INSTALLATION, Air Breather Hose.>

12) Insert inhibitor switch and transmission connector into stay.

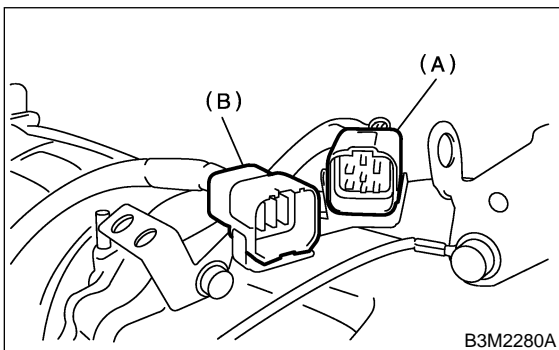

- (A) Transmission harness
- (B) Inhibitor switch harness

13) Insert the input shaft while turning lightly by hand.

**CAUTION:**

**Be careful not to damage the bushing.**

**Normal protrusion A:**

**50 — 55 mm (1.97 — 2.17 in)**

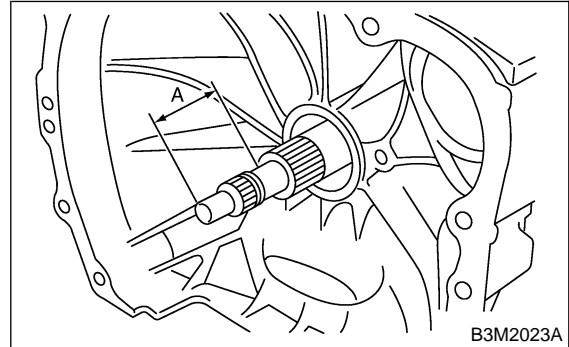

14) Install the torque converter clutch assembly.

<Ref. to AT-35, INSTALLATION, Torque Converter Clutch Assembly.>

**C: DISASSEMBLY** S510593A06

1) Remove oil strainer from lower control valve body.

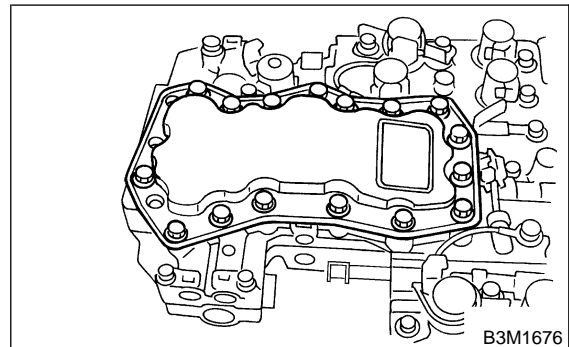

# CONTROL VALVE BODY ASSEMBLY

Automatic Transmission

2) Remove the duty solenoids, solenoids and sensor from the lower valve body.

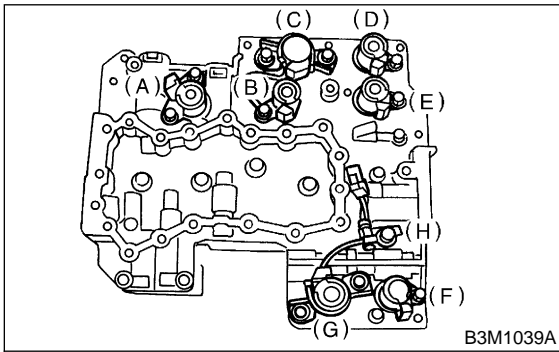

- (A) Lock-up duty solenoid (Blue)
- (B) Low clutch timing solenoid (Gray)
- (C) Line pressure duty solenoid (Red)
- (D) Shift solenoid 1 (Yellow)
- (E) Shift solenoid 2 (Green)
- (F) 2-4 brake timing solenoid (Black)
- (G) 2-4 brake duty solenoid (Red)
- (H) ATF temperature sensor

3) Remove the upper-lower valve body tightening bolts.

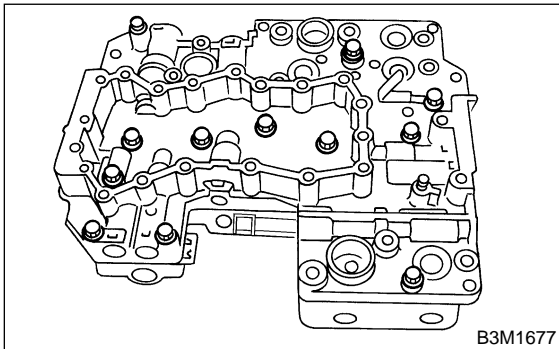

4) Separate the control valve body.

NOTE:

- Do not lose the ten (10) steel balls contained in the upper valve body and middle valve body.
- Do not lose strainers contained in the lower valve body.

NOTE:

During ordinary servicing, clean the control valve bodies in this condition, without further disassembly. In the event of a seized clutch or other problem, disassemble the control valve bodies further, and clean the component parts.

5) Remove upper separator plate from middle valve body.

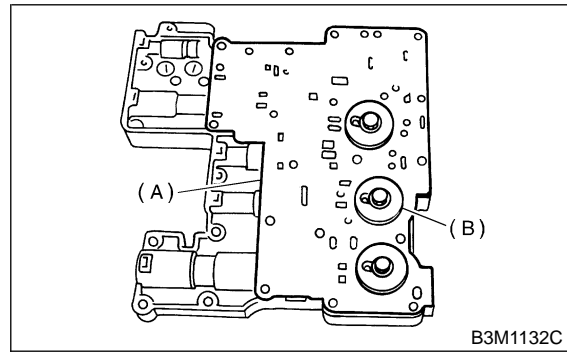

- (A) Upper separator plate
- (B) Side plate

6) Remove valve springs from upper valve body.  
7) Using air compressor, remove accumulator piston from upper valve body.

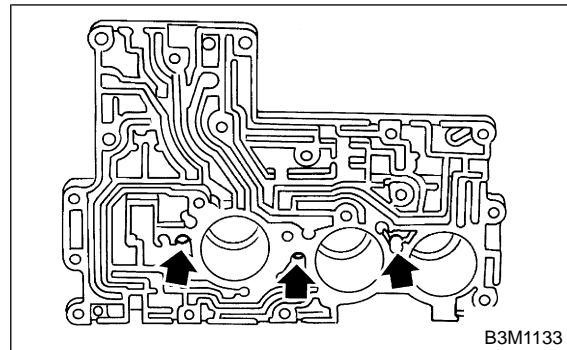

## D: ASSEMBLY S510593A02

1) Install accumulator pistons, valve springs and steel balls to upper valve body.

NOTE:

Insert steel balls in their proper positions.

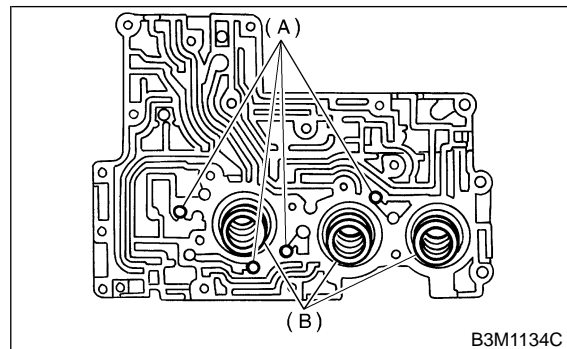

- (A) Steel balls
- (B) Valve spring

# CONTROL VALVE BODY ASSEMBLY

Automatic Transmission

2) Install support plate and upper separator plate to middle valve body.

**NOTE:**

Align the hole in side plate with the hole in separator plate.

**Tightening torque:**

**8 N·m (0.8 kgf·m, 5.8 ft·lb)**

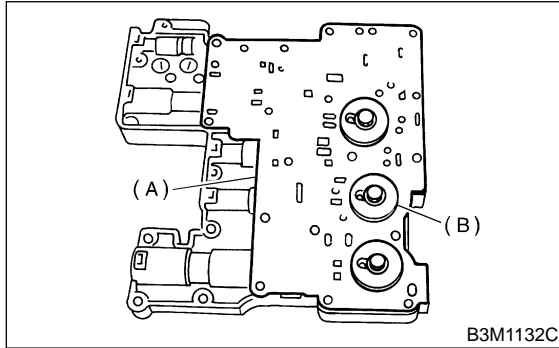

- (A) Upper separator plate
- (B) Side plate

3) Install steel balls to middle valve body.

**NOTE:**

Insert steel balls in their proper positions.

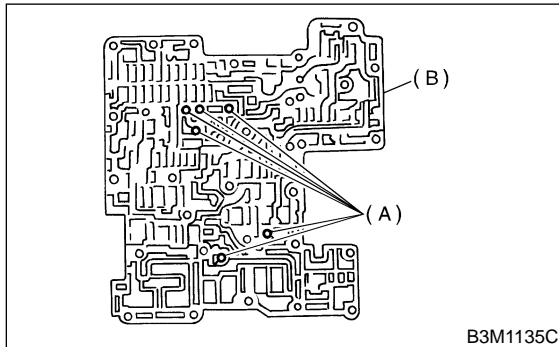

- (A) Steel ball
- (B) Middle valve body

4) Install three filters to lower valve body.

**NOTE:**

Pay attention to the location of filters.

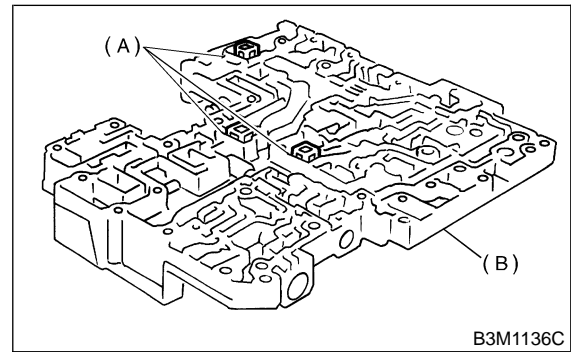

- (A) Strainer
- (B) Lower valve body

5) Install lower separator plate to lower valve body.

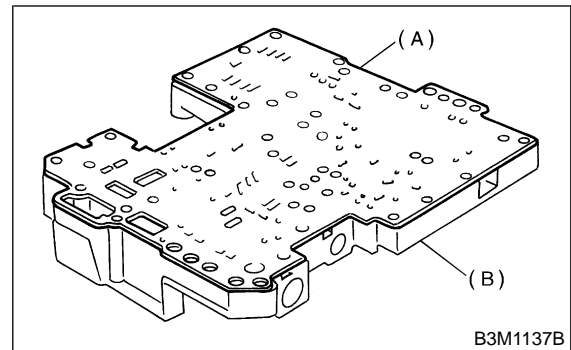

- (A) Lower separator plate
- (B) Lower valve body

6) Temporarily assemble valve body.

**NOTE:**

Be careful not to drop the middle valve body and upper body interior steel ball, or the lower body filter.

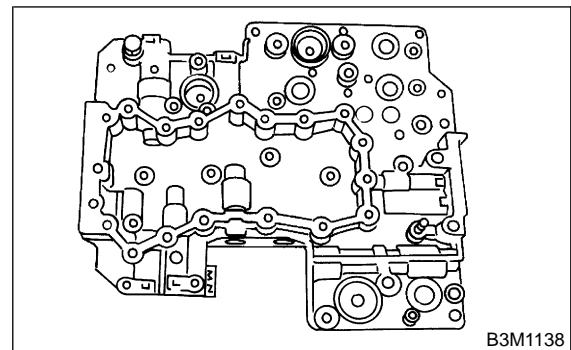

# CONTROL VALVE BODY ASSEMBLY

Automatic Transmission

7) Tighten bolts.

**Tightening torque:**

**8 N·m (0.8 kgf-m, 5.8 ft-lb)**

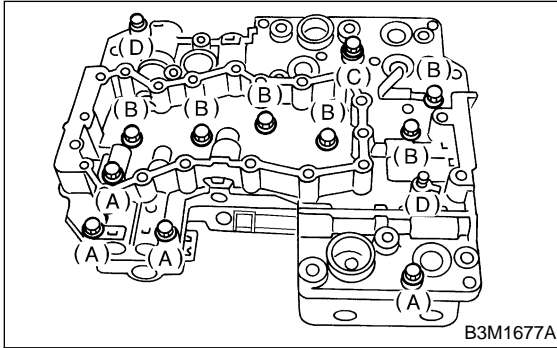

- (A) Short bolts
- (B) Middle bolts
- (C) Long bolt
- (D) Reamer bolts

8) Install the sensor, solenoids and duty solenoids.

**Tightening torque:**

**T: 8 N·m (0.8 kgf-m, 5.8 ft-lb)**

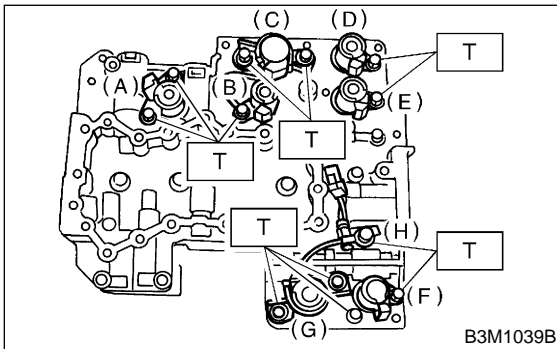

- (A) Lock-up duty solenoid (Blue)
- (B) Low clutch timing solenoid (Gray)
- (C) Line pressure duty solenoid (Red)
- (D) Shift solenoid 1 (Yellow)
- (E) Shift solenoid 2 (Green)
- (F) 2-4 brake timing solenoid (Black)
- (G) 2-4 brake duty solenoid (Red)
- (H) ATF temperature sensor

9) Install oil strainer to lower valve body.

**Tightening torque:**

**8 N·m (0.8 kgf-m, 5.8 ft-lb)**

## E: INSPECTION S510593A10

Make sure that each component is free of harmful gouges, cuts, or dust.

## 21. Control Valve Body Assembly

S510593

### A: REMOVAL

S510593A18

- 1) Extract the torque converter clutch assembly. <Ref. to AT-35, REMOVAL, Torque Converter Clutch Assembly.>
- 2) Remove the input shaft.

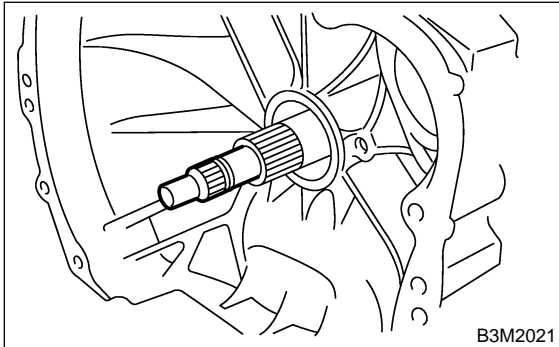

- 3) Disconnect the air breather hose. <Ref. to AT-28, REMOVAL, Air Breather Hose.>
- 4) Disconnect transmission harness connector from stay.

**NOTE:**

Lift-up lever behind the connector and disconnect it from stay.

- 5) Disconnect inhibitor switch from stay.
- 6) Remove the oil charger pipe. <Ref. to AT-29, REMOVAL, Oil Charger Pipe.>
- 7) To plug the hole, wrap vinyl tape around the nipple attached to the air breather hose.
- 8) Remove pitching stopper bracket.
- 9) Remove the inhibitor switch.

**NOTE:**

For removal procedures of inhibitor switch, refer to "AT" sections for each model.

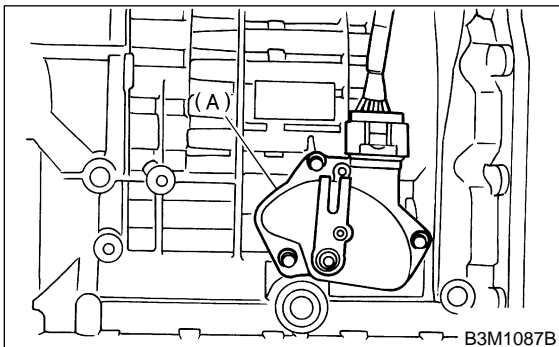

(A) Inhibitor switch

- 10) Prepare a block of wood. Turn the transmission case over, and support it with the block of wood.

**NOTE:**

Turn the transmission case in the direction the inhibitor switch was installed.

- 11) Remove the oil pan.

**NOTE:**

Use a scraper to remove oil pan.

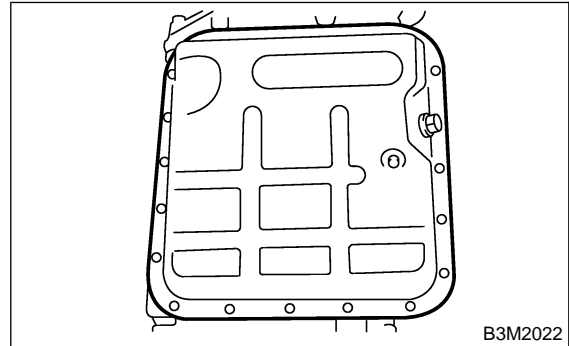

- 12) Disconnect the harness connectors for the solenoids, duty solenoids, ATF temperature sensor and the ground cord.

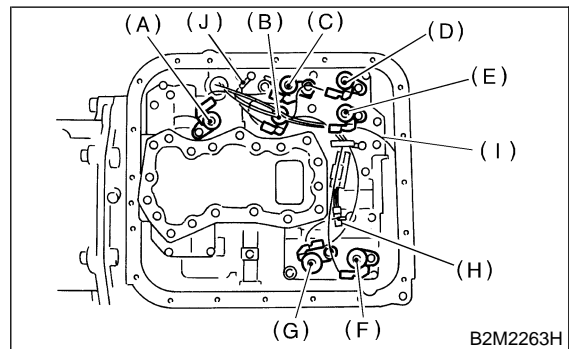

- (A) Lock-up duty solenoid (Blue)
- (B) Low clutch timing solenoid (Gray)
- (C) Line pressure duty solenoid (Red)
- (D) Shift solenoid 2 (Yellow)
- (E) Shift solenoid 1 (Green)
- (F) 2-4 brake timing solenoid (Black)
- (G) 2-4 brake duty solenoid (Red)
- (H) ATF temperature sensor
- (I) Transfer duty solenoid (Brown)
- (J) Transmission ground

- 13) Remove the control valve body assembly.

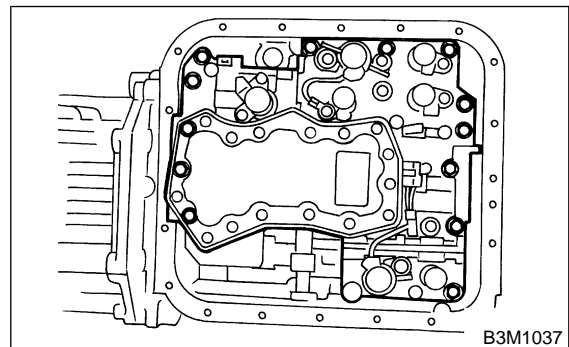

# CONTROL VALVE BODY ASSEMBLY

Automatic Transmission

## B: INSTALLATION S510593A11

- 1) Set the select lever in range "N".
- 2) Align the groove of the manual valve to the protrusion of the manual lever, and then install the control valve body assembly.

**Tightening torque:**  
**8 N·m (0.8 kgf-m, 5.8 ft-lb)**

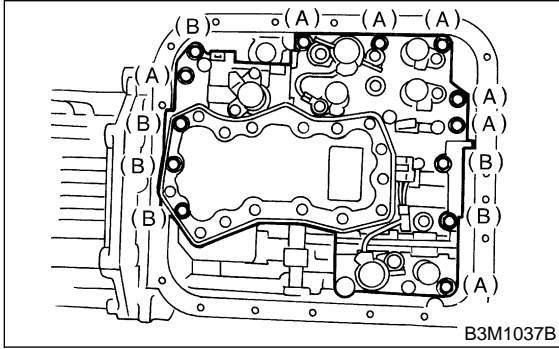

- (A) Short bolts
- (B) Long bolts

- 3) Tighten the valve body to the specified torque.

**NOTE:**  
 Tighten the control valve mounting bolts evenly.

**Tightening torque:**  
**8 N·m (0.8 kgf-m, 5.8 ft-lb)**

- 4) Connect all connectors.

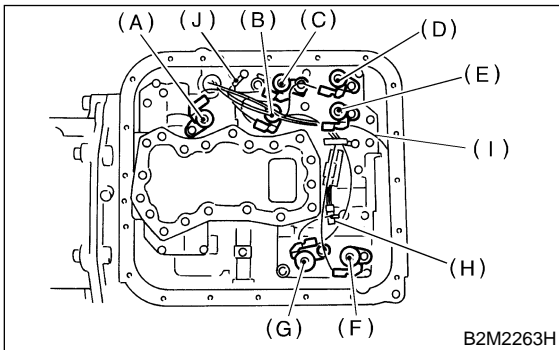

- (A) Lock-up duty solenoid (Blue)
- (B) Low clutch timing solenoid (Gray)
- (C) Line pressure duty solenoid (Red)
- (D) Shift solenoid 2 (Yellow)
- (E) Shift solenoid 1 (Green)
- (F) 2-4 brake timing solenoid (Black)
- (G) 2-4 brake duty solenoid (Red)
- (H) ATF temperature sensor
- (I) Transfer duty solenoid (Brown)
- (J) Transmission ground

- 5) Attach the magnet at the specified position.

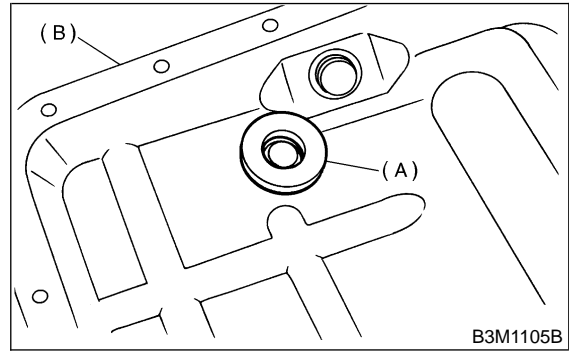

- (A) Magnet
- (B) Oil pan

- 6) Apply proper amount of liquid gasket to the entire oil pan mating surface.

**Liquid gasket:**  
**THREE BOND 1217B**

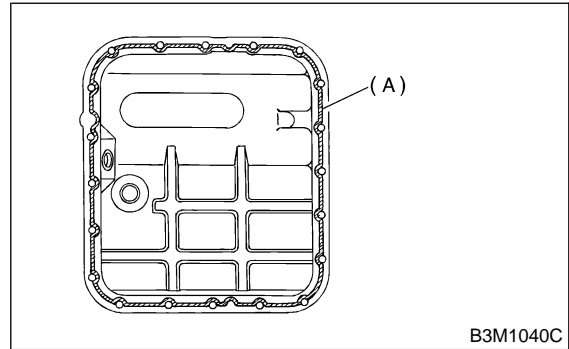

- (A) THREE BOND (Part No. 1217B)

- 7) Besides bolt hole on transmission side, completely fill in liquid gasket at three holes.

**Fluid packing:**  
**THREE BOND 1217B**

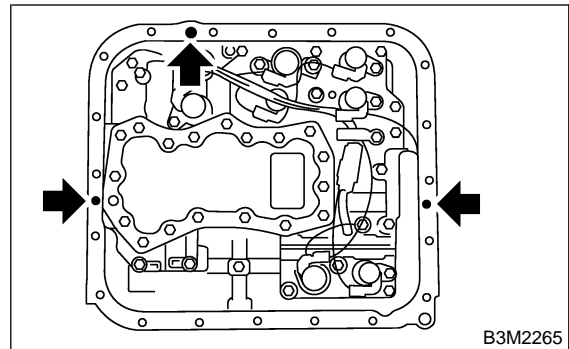

8) Install the oil pan to the transmission case assembly.

**NOTE:**

Tighten the bolts evenly.

**Tightening torque:**

**5 N·m (0.50 kgf-m, 3.6 ft-lb)**

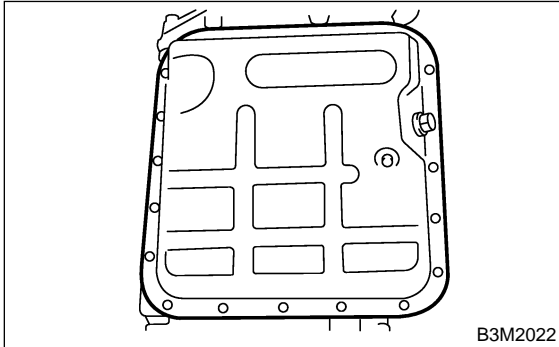

9) Turn over the transmission case to its original position.

10) Install inhibitor switch and adjust the inhibitor switch by referring to Supplement AT section.

11) Install air breather hose. <Ref. to AT-28, INSTALLATION, Air Breather Hose.>

12) Insert inhibitor switch and transmission connector into stay.

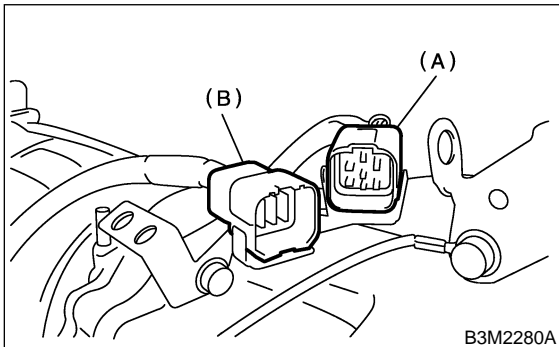

- (A) Transmission harness
- (B) Inhibitor switch harness

13) Insert the input shaft while turning lightly by hand.

**CAUTION:**

**Be careful not to damage the bushing.**

**Normal protrusion A:**

**50 — 55 mm (1.97 — 2.17 in)**

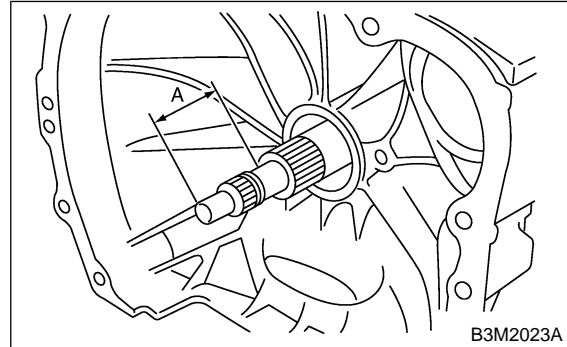

14) Install the torque converter clutch assembly.

<Ref. to AT-35, INSTALLATION, Torque Converter Clutch Assembly.>

**C: DISASSEMBLY** S510593A06

1) Remove oil strainer from lower control valve body.

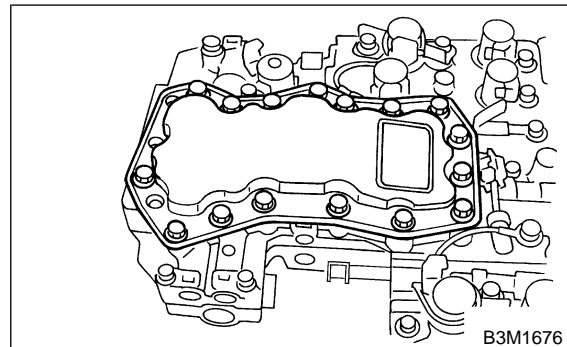

# CONTROL VALVE BODY ASSEMBLY

Automatic Transmission

2) Remove the duty solenoids, solenoids and sensor from the lower valve body.

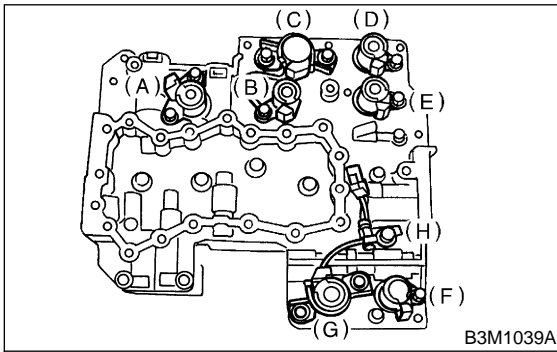

- (A) Lock-up duty solenoid (Blue)
- (B) Low clutch timing solenoid (Gray)
- (C) Line pressure duty solenoid (Red)
- (D) Shift solenoid 1 (Yellow)
- (E) Shift solenoid 2 (Green)
- (F) 2-4 brake timing solenoid (Black)
- (G) 2-4 brake duty solenoid (Red)
- (H) ATF temperature sensor

3) Remove the upper-lower valve body tightening bolts.

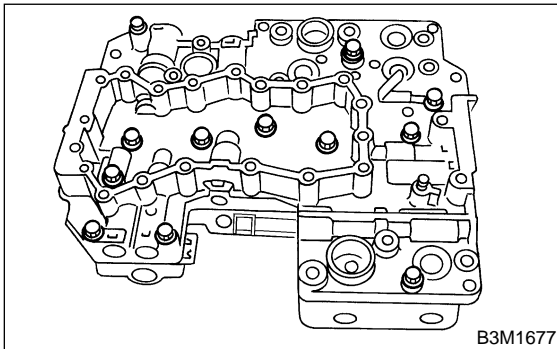

4) Separate the control valve body.

NOTE:

- Do not lose the ten (10) steel balls contained in the upper valve body and middle valve body.
- Do not lose strainers contained in the lower valve body.

NOTE:

During ordinary servicing, clean the control valve bodies in this condition, without further disassembly. In the event of a seized clutch or other problem, disassemble the control valve bodies further, and clean the component parts.

5) Remove upper separator plate from middle valve body.

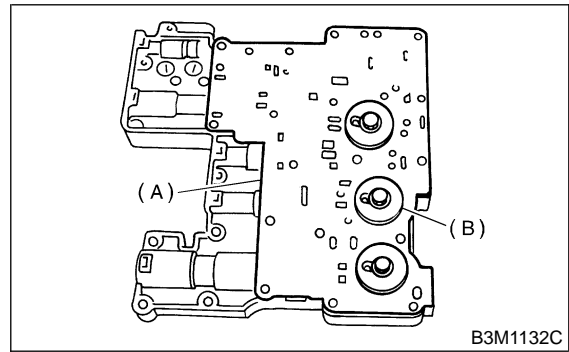

- (A) Upper separator plate
- (B) Side plate

6) Remove valve springs from upper valve body.  
7) Using air compressor, remove accumulator piston from upper valve body.

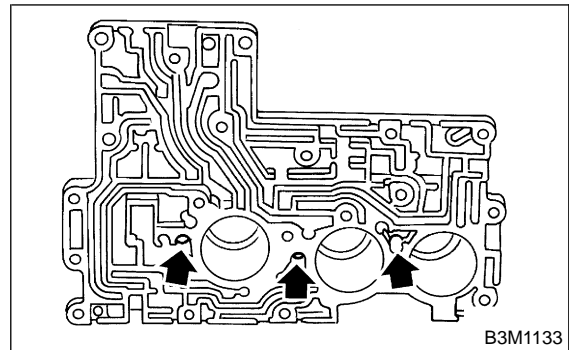

## D: ASSEMBLY S510593A02

1) Install accumulator pistons, valve springs and steel balls to upper valve body.

NOTE:

Insert steel balls in their proper positions.

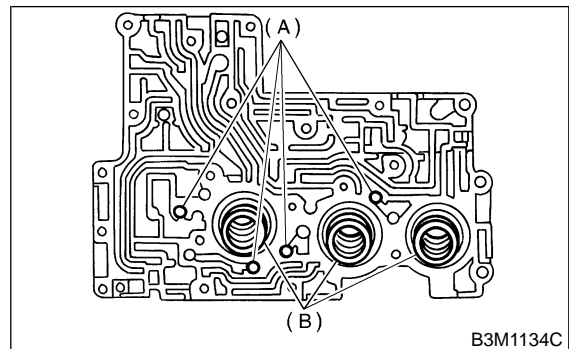

- (A) Steel balls
- (B) Valve spring



# CONTROL VALVE BODY ASSEMBLY

Automatic Transmission

2) Install support plate and upper separator plate to middle valve body.

**NOTE:**

Align the hole in side plate with the hole in separator plate.

**Tightening torque:**

**8 N·m (0.8 kgf·m, 5.8 ft·lb)**

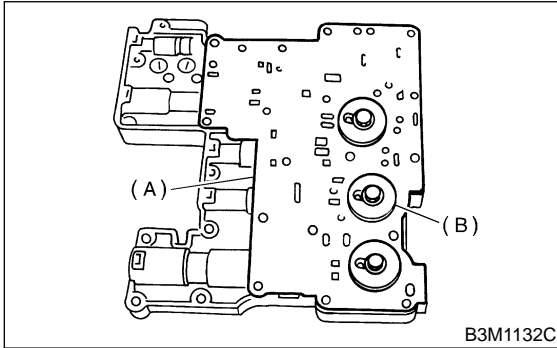

- (A) Upper separator plate
- (B) Side plate

3) Install steel balls to middle valve body.

**NOTE:**

Insert steel balls in their proper positions.

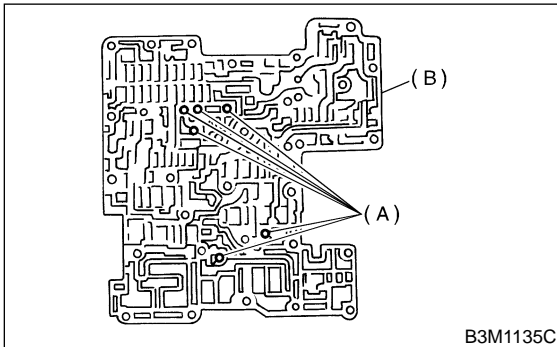

- (A) Steel ball
- (B) Middle valve body

4) Install three filters to lower valve body.

**NOTE:**

Pay attention to the location of filters.

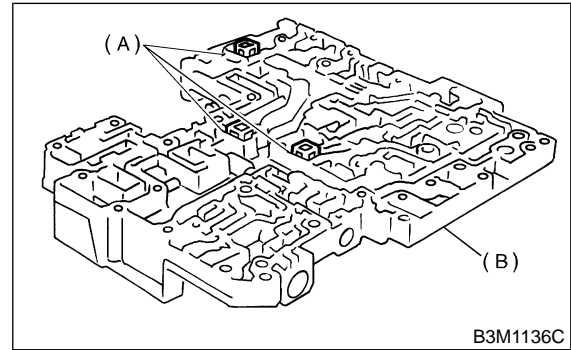

- (A) Strainer
- (B) Lower valve body

5) Install lower separator plate to lower valve body.

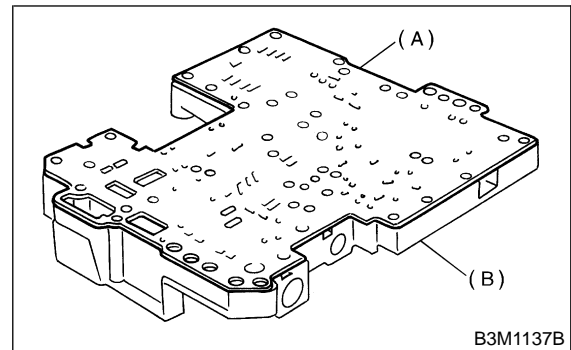

- (A) Lower separator plate
- (B) Lower valve body

6) Temporarily assemble valve body.

**NOTE:**

Be careful not to drop the middle valve body and upper body interior steel ball, or the lower body filter.

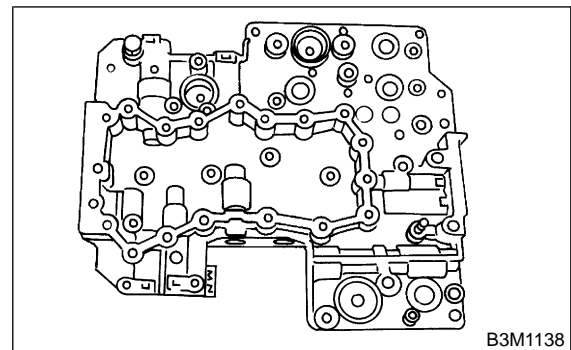

# CONTROL VALVE BODY ASSEMBLY

Automatic Transmission

7) Tighten bolts.

**Tightening torque:**

**8 N·m (0.8 kgf-m, 5.8 ft-lb)**

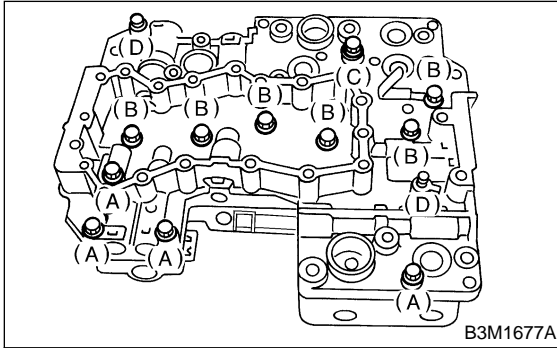

- (A) Short bolts
- (B) Middle bolts
- (C) Long bolt
- (D) Reamer bolts

8) Install the sensor, solenoids and duty solenoids.

**Tightening torque:**

**T: 8 N·m (0.8 kgf-m, 5.8 ft-lb)**

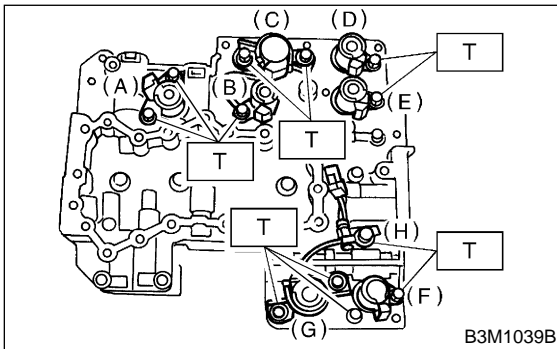

- (A) Lock-up duty solenoid (Blue)
- (B) Low clutch timing solenoid (Gray)
- (C) Line pressure duty solenoid (Red)
- (D) Shift solenoid 1 (Yellow)
- (E) Shift solenoid 2 (Green)
- (F) 2-4 brake timing solenoid (Black)
- (G) 2-4 brake duty solenoid (Red)
- (H) ATF temperature sensor

9) Install oil strainer to lower valve body.

**Tightening torque:**

**8 N·m (0.8 kgf-m, 5.8 ft-lb)**

## E: INSPECTION S510593A10

Make sure that each component is free of harmful gouges, cuts, or dust.

## 22. High Clutch and Reverse Clutch

S510213

### A: REMOVAL

S510213A18

- 1) Extract the torque converter clutch assembly.  
<Ref. to AT-35, REMOVAL, Torque Converter Clutch Assembly.>
- 2) Remove the input shaft.

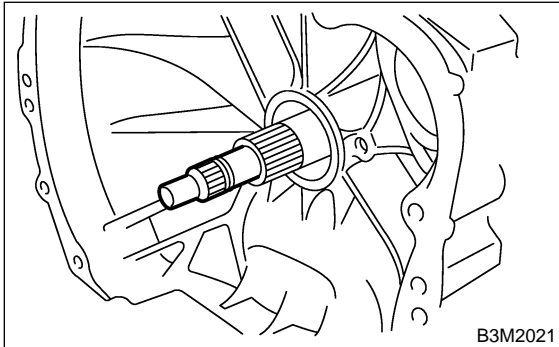

B3M2021

- 3) Disconnect transmission harness connector from stay.

#### NOTE:

Lift-up lever behind the connector and disconnect it from stay.

- 4) Disconnect inhibitor switch connector from stay.
- 5) Disconnect the air breather hose.
- 6) Remove the oil charger pipe. <Ref. to AT-29, REMOVAL, Oil Charger Pipe.>
- 7) Remove the oil cooler inlet and outlet pipes. <Ref. to AT-30, REMOVAL, Oil Cooler Pipes.>
- 8) Separation of torque converter clutch case and transmission case. <Ref. to AT-58, REMOVAL, Torque Converter Clutch Case.>
- 9) Remove the oil pump housing. <Ref. to AT-62, REMOVAL, Oil Pump.>
- 10) Take out the high clutch, thrust needle bearing and reverse clutch assembly.

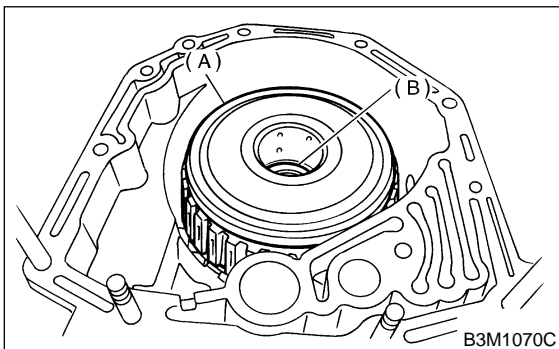

B3M1070C

- (A) High clutch and reverse clutch assembly
- (B) Thrust needle bearing

- 11) Take out the high clutch hub and the thrust bearing.

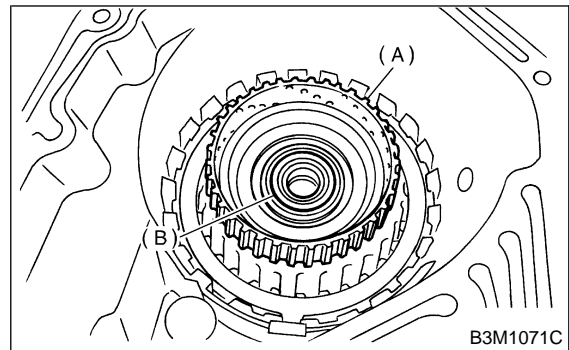

B3M1071C

- (A) High clutch hub
- (B) Thrust needle bearing

# HIGH CLUTCH AND REVERSE CLUTCH

Automatic Transmission

## B: INSTALLATION S510213A11

1) Install the high clutch hub and thrust needle bearing.

Attach the thrust needle bearing to the hub with vaseline and install the hub by correctly engaging the splines of the front planetary carrier.

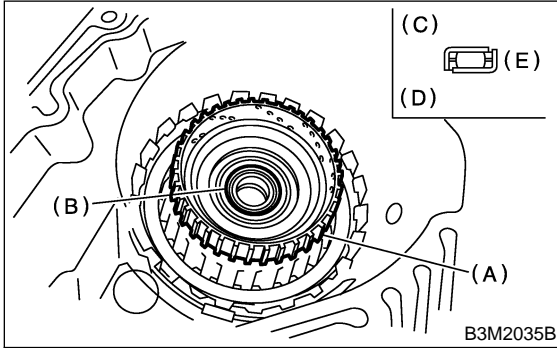

- (A) High clutch hub
- (B) Thrust needle bearing
- (C) Up side
- (D) Down side
- (E) Outside

2) Install the high clutch assembly.

NOTE:

Correctly engage the high clutch hub and clutch splines.

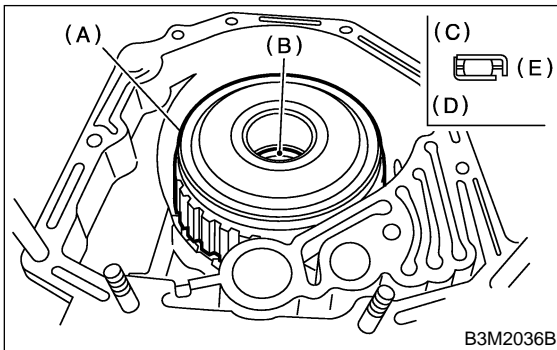

- (A) High clutch and reverse clutch assembly
- (B) Thrust needle bearing
- (C) Up side
- (D) Down side
- (E) Outside

3) Adjust total end play. <Ref. to AT-66, ADJUSTMENT, Oil Pump.>

4) Install the oil pump housing assembly.

5) Install the torque converter clutch case assembly to the transmission case assembly. <Ref. to AT-59, INSTALLATION, Torque Converter Clutch Case.>

6) Insert inhibitor switch and transmission connector into stay.

7) Install air breather hose. <Ref. to AT-28, INSTALLATION, Air Breather Hose.>

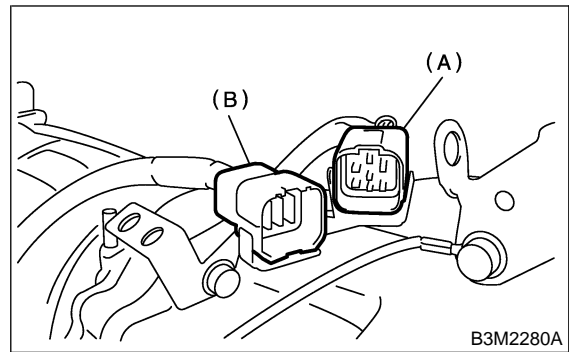

- (A) Transmission harness
- (B) Inhibitor switch harness

8) Install oil cooler pipes. <Ref. to AT-30, INSTALLATION, Oil Cooler Pipes.>

9) Install the oil charger pipe with O-ring. <Ref. to AT-29, INSTALLATION, Oil Charger Pipe.>

10) Insert the input shaft while turning lightly by hand.

**CAUTION:**

**Be careful not to damage the bushing.**

**Normal protrusion A:**

**50 — 55 mm (1.97 — 2.17 in)**

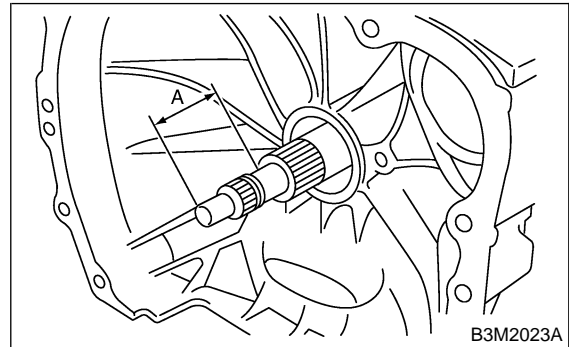

11) Install the torque converter clutch assembly. <Ref. to AT-35, INSTALLATION, Torque Converter Clutch Assembly.>

## C: DISASSEMBLY S510213A06

1) Remove the snap ring, and take out the retaining plate, drive plates, driven plates.

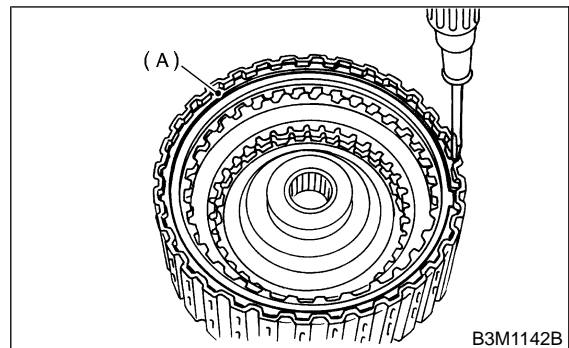

- (A) Snap ring

# HIGH CLUTCH AND REVERSE CLUTCH

Automatic Transmission

2) Remove snap ring, and take out the retaining plate, drive plates and driven plates.

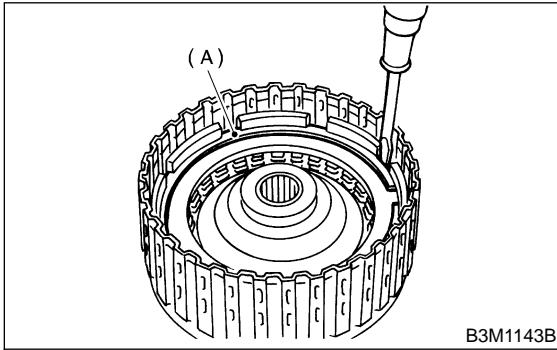

(A) Snap ring

3) Using ST1 and ST2, remove snap ring.  
ST1 398673600 COMPRESSOR  
ST2 498627100 SEAT

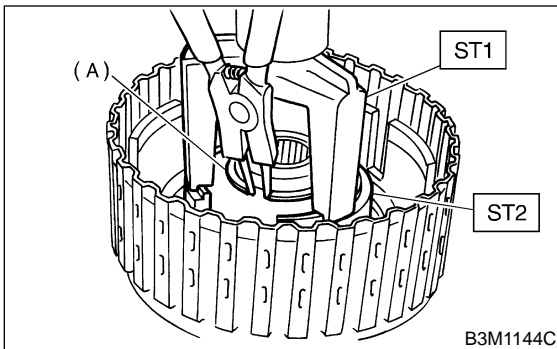

(A) Snap ring

4) Take out clutch cover, spring retainer, high clutch piston and reverse clutch piston.

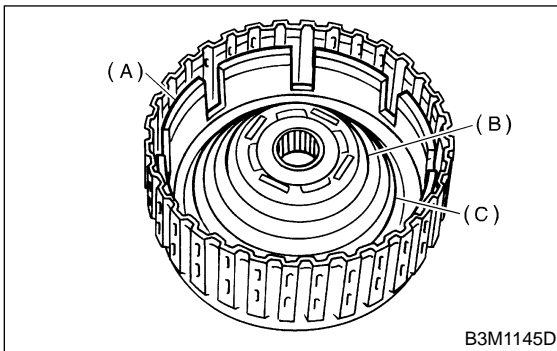

(A) Reverse clutch piston  
(B) Cover  
(C) Return spring

5) Remove seal rings and lip seal from high clutch piston and reverse clutch piston.

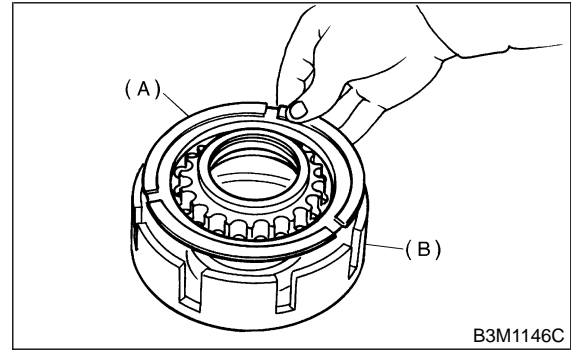

(A) High clutch piston  
(B) Reverse clutch piston

## D: ASSEMBLY S510213A02

1) Install seal rings and lip seal to high clutch piston and reverse clutch piston.

2) Install high clutch piston to reverse clutch piston.

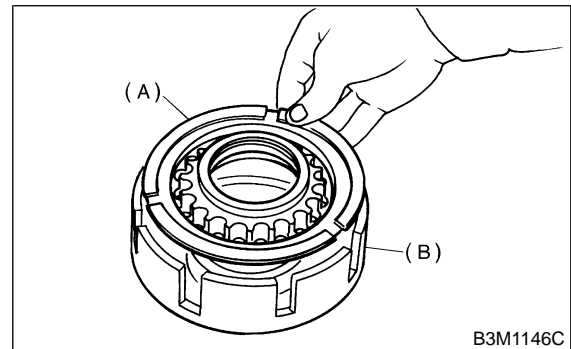

(A) High clutch piston  
(B) Reverse clutch piston

3) Install reverse clutch to high clutch drum.

### NOTE:

Align the groove on the reverse clutch piston with the groove on the high clutch drum during installation.

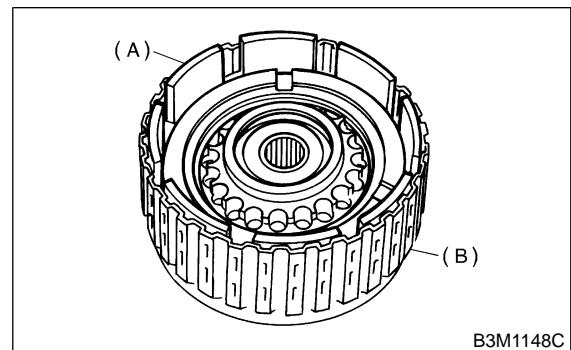

(A) Reverse clutch piston  
(B) High clutch drum

# HIGH CLUTCH AND REVERSE CLUTCH

Automatic Transmission

4) Install spring retainer to high clutch piston.

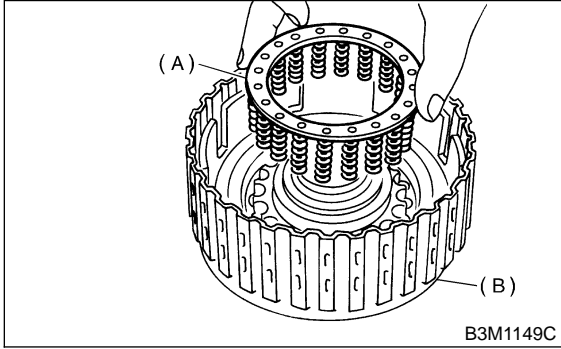

- (A) Return spring
- (B) High clutch drum

5) Install ST to high clutch piston.  
ST 498437000 HIGH CLUTCH PISTON GAUGE

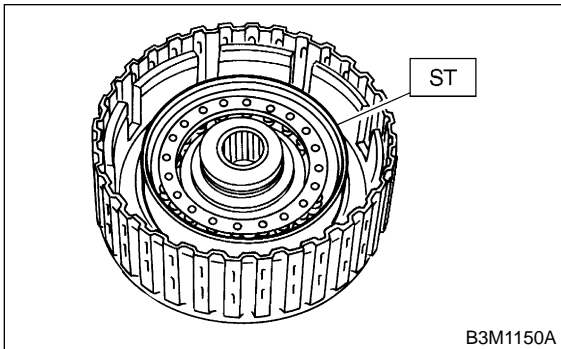

6) Install cover to high clutch piston.

NOTE:

Be careful not to fold over the high clutch piston seal during installation.

7) Using ST1 and ST2, install snap ring.

NOTE:

After installing snap ring, remove STs.

- ST1 398673600 COMPRESSOR
- ST2 498627100 SEAT
- ST3 498437000 HIGH CLUTCH PISTON GAUGE

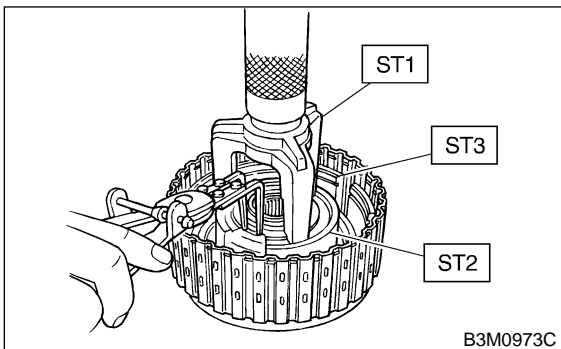

8) Install driven plate, drive plate and retaining plate to high clutch drum.

NOTE:

Install thicker driven plate on the piston side.

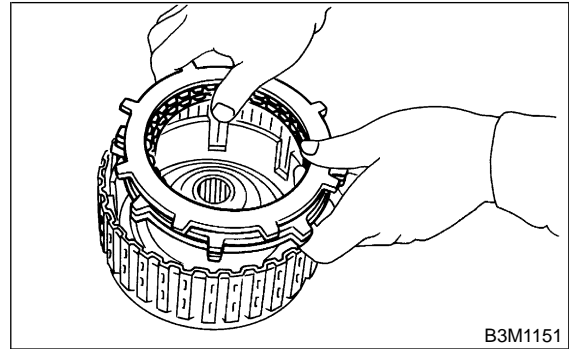

9) Install snap ring to high clutch drum.

10) Apply compressed air intermittently to check for operation.

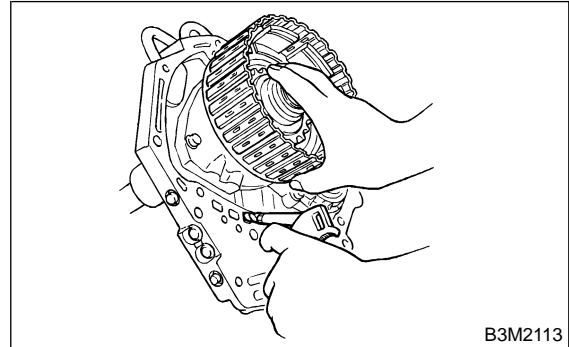

11) Measure the clearance between the retaining plate and snap ring. <Ref. to AT-91, INSPECTION, High Clutch and Reverse Clutch.>

12) Install driven plate, drive plate, retaining plate and snap ring.

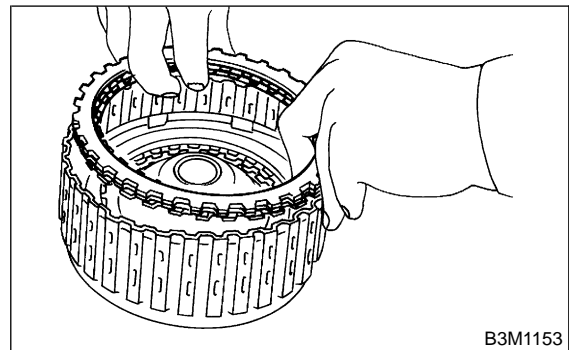

13) Apply compressed air intermittently to check for operation.

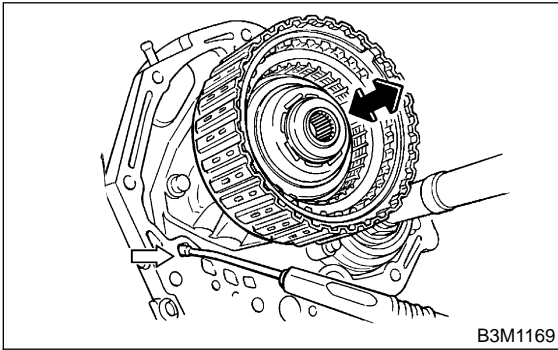

14) Measure the clearance between the retaining plate and snap ring. <Ref. to AT-90, INSPECTION, High Clutch and Reverse Clutch.>

## E: INSPECTION S510213A10

- Drive plate facing for wear and damage
- Snap ring for wear, return spring for setting and breakage, and snap ring retainer for deformation
- Lip seal and lathe cut ring for damage
- Piston and drum check ball for operation
- Adjust total end play. <Ref. to AT-66, ADJUSTMENT, Oil Pump.>

1) Inspect clearance between the retaining plate and snap ring. (High clutch)

### NOTE:

Do not press down retaining plate during clearance measurements.

### Standard value:

**0.8 — 1.1 mm (0.031 — 0.043 in)**

### Allowable limit:

**1.5 mm (0.059 in)**

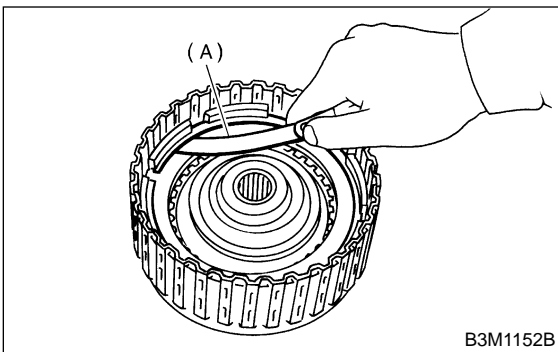

(A) Thickness gauge

If specified tolerance limits are exceeded, select a suitable high clutch retaining plate.

High clutch retaining plate	
Part No.	Thickness mm (in)
31567AA710	4.7 (0.185)
31567AA720	4.8 (0.189)
31567AA730	4.9 (0.193)
31567AA740	5.0 (0.197)
31567AA670	5.1 (0.201)
31567AA680	5.2 (0.205)
31567AA690	5.3 (0.209)
31567AA700	5.4 (0.213)

2) Inspect clearance between retaining plate and snap ring. (Reverse clutch)

### NOTE:

Do not press down retaining plate during clearance measurements.

### Standard value:

**0.5 — 0.8 mm (0.020 — 0.031 in)**

### Allowable limit:

**1.2 mm (0.047 in)**

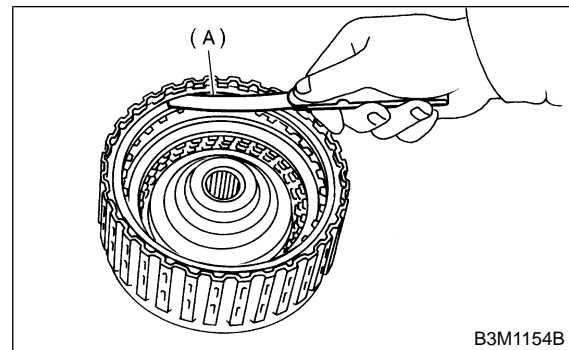

(A) Thickness gauge

If specified tolerance limits are exceeded, select a suitable high clutch retaining plate.

Reverse clutch retaining plates	
Part No.	Thickness mm (in)
31567AA910	4.0 (0.157)
31567AA920	4.2 (0.165)
31567AA930	4.4 (0.173)
31567AA940	4.6 (0.181)
31567AA950	4.8 (0.189)
31567AA960	5.0 (0.197)
31567AA970	5.2 (0.205)
31567AA980	5.4 (0.213)

## 22. High Clutch and Reverse Clutch

S510213

### A: REMOVAL

S510213A18

- 1) Extract the torque converter clutch assembly.  
<Ref. to AT-35, REMOVAL, Torque Converter Clutch Assembly.>
- 2) Remove the input shaft.

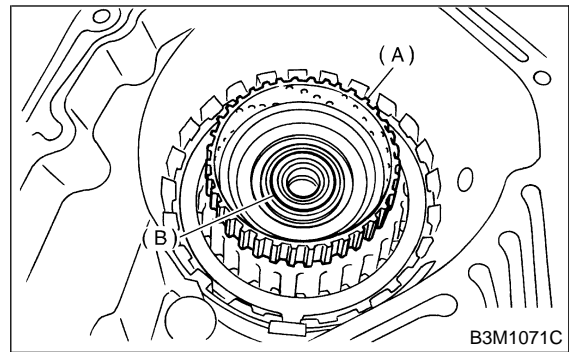
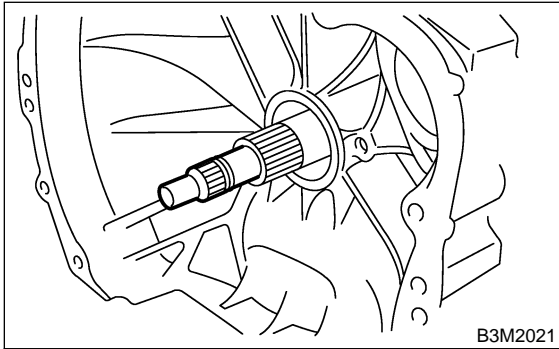

- (A) High clutch hub
- (B) Thrust needle bearing

- 3) Disconnect transmission harness connector from stay.

#### NOTE:

Lift-up lever behind the connector and disconnect it from stay.

- 4) Disconnect inhibitor switch connector from stay.
- 5) Disconnect the air breather hose.
- 6) Remove the oil charger pipe. <Ref. to AT-29, REMOVAL, Oil Charger Pipe.>
- 7) Remove the oil cooler inlet and outlet pipes. <Ref. to AT-30, REMOVAL, Oil Cooler Pipes.>
- 8) Separation of torque converter clutch case and transmission case. <Ref. to AT-58, REMOVAL, Torque Converter Clutch Case.>
- 9) Remove the oil pump housing. <Ref. to AT-62, REMOVAL, Oil Pump.>
- 10) Take out the high clutch, thrust needle bearing and reverse clutch assembly.

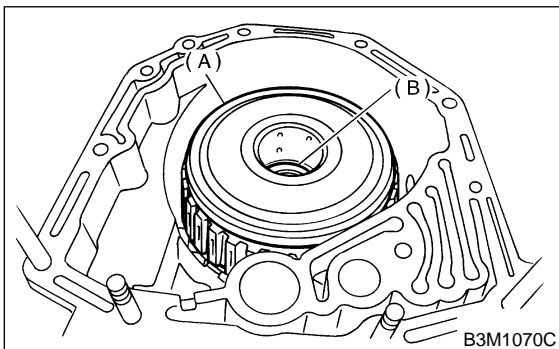

- (A) High clutch and reverse clutch assembly
- (B) Thrust needle bearing

- 11) Take out the high clutch hub and the thrust bearing.



# HIGH CLUTCH AND REVERSE CLUTCH

Automatic Transmission

## B: INSTALLATION S510213A11

1) Install the high clutch hub and thrust needle bearing.

Attach the thrust needle bearing to the hub with vaseline and install the hub by correctly engaging the splines of the front planetary carrier.

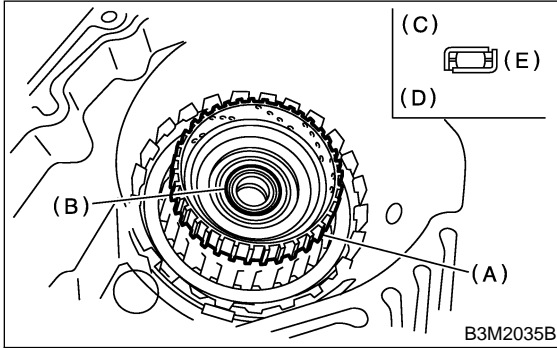

- (A) High clutch hub
- (B) Thrust needle bearing
- (C) Up side
- (D) Down side
- (E) Outside

2) Install the high clutch assembly.

NOTE:

Correctly engage the high clutch hub and clutch splines.

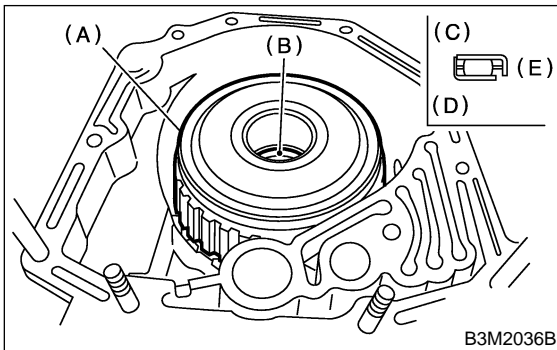

- (A) High clutch and reverse clutch assembly
- (B) Thrust needle bearing
- (C) Up side
- (D) Down side
- (E) Outside

3) Adjust total end play. <Ref. to AT-66, ADJUSTMENT, Oil Pump.>

4) Install the oil pump housing assembly.

5) Install the torque converter clutch case assembly to the transmission case assembly. <Ref. to AT-59, INSTALLATION, Torque Converter Clutch Case.>

6) Insert inhibitor switch and transmission connector into stay.

7) Install air breather hose. <Ref. to AT-28, INSTALLATION, Air Breather Hose.>

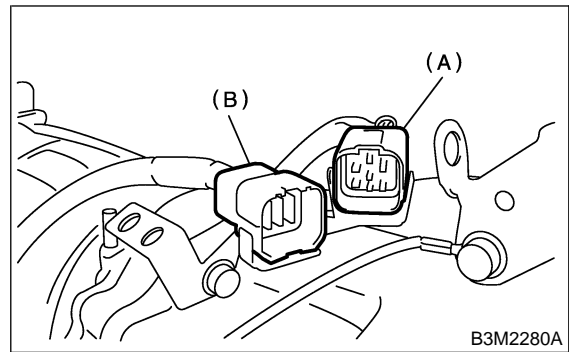

- (A) Transmission harness
- (B) Inhibitor switch harness

8) Install oil cooler pipes. <Ref. to AT-30, INSTALLATION, Oil Cooler Pipes.>

9) Install the oil charger pipe with O-ring. <Ref. to AT-29, INSTALLATION, Oil Charger Pipe.>

10) Insert the input shaft while turning lightly by hand.

**CAUTION:**

**Be careful not to damage the bushing.**

**Normal protrusion A:**

**50 — 55 mm (1.97 — 2.17 in)**

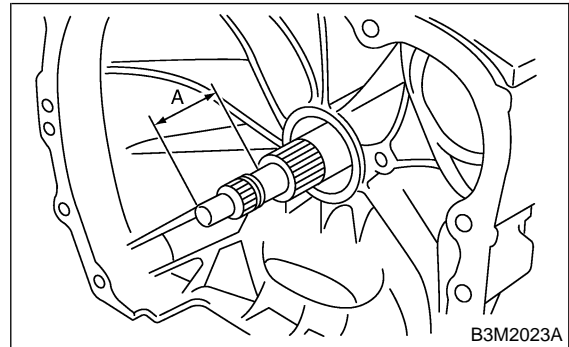

11) Install the torque converter clutch assembly. <Ref. to AT-35, INSTALLATION, Torque Converter Clutch Assembly.>

## C: DISASSEMBLY S510213A06

1) Remove the snap ring, and take out the retaining plate, drive plates, driven plates.

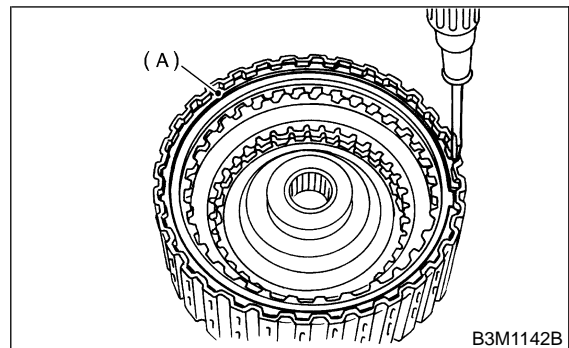

- (A) Snap ring

# HIGH CLUTCH AND REVERSE CLUTCH

Automatic Transmission

2) Remove snap ring, and take out the retaining plate, drive plates and driven plates.

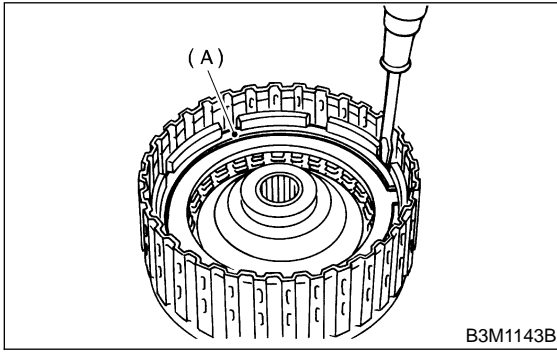

(A) Snap ring

3) Using ST1 and ST2, remove snap ring.  
ST1 398673600 COMPRESSOR  
ST2 498627100 SEAT

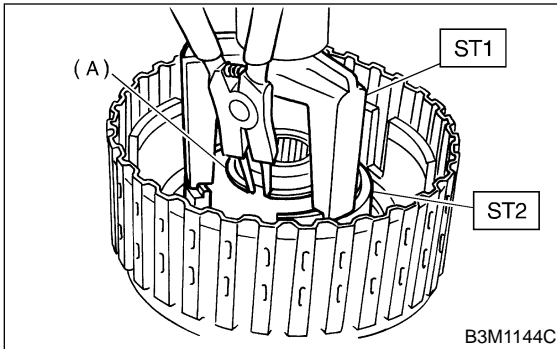

(A) Snap ring

4) Take out clutch cover, spring retainer, high clutch piston and reverse clutch piston.

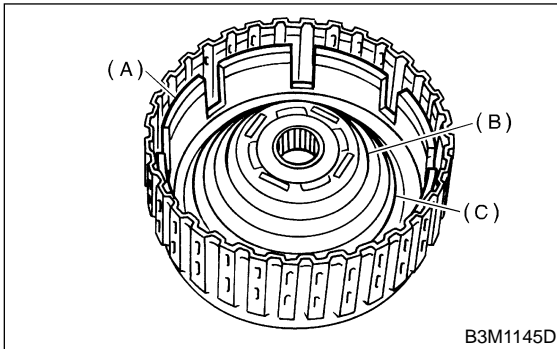

(A) Reverse clutch piston  
(B) Cover  
(C) Return spring

5) Remove seal rings and lip seal from high clutch piston and reverse clutch piston.

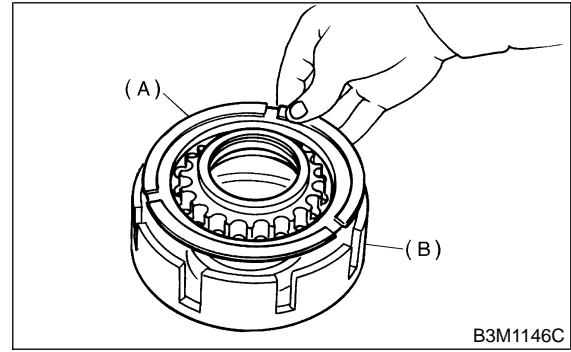

(A) High clutch piston  
(B) Reverse clutch piston

## D: ASSEMBLY S510213A02

1) Install seal rings and lip seal to high clutch piston and reverse clutch piston.

2) Install high clutch piston to reverse clutch piston.

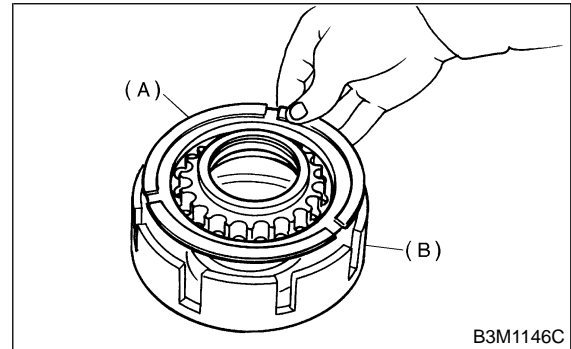

(A) High clutch piston  
(B) Reverse clutch piston

3) Install reverse clutch to high clutch drum.

### NOTE:

Align the groove on the reverse clutch piston with the groove on the high clutch drum during installation.

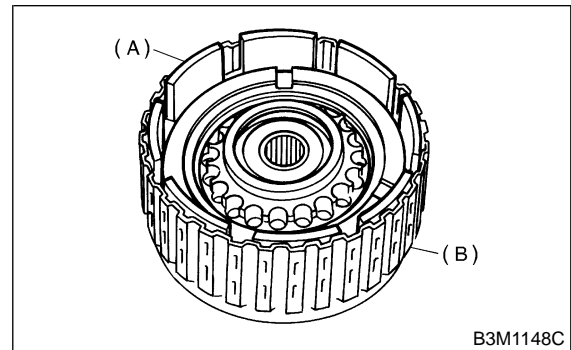

(A) Reverse clutch piston  
(B) High clutch drum

# HIGH CLUTCH AND REVERSE CLUTCH

Automatic Transmission

4) Install spring retainer to high clutch piston.

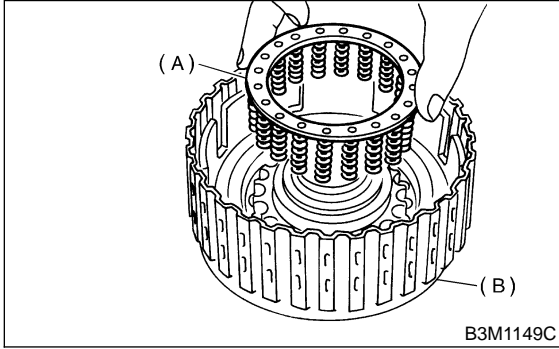

- (A) Return spring
- (B) High clutch drum

5) Install ST to high clutch piston.  
ST 498437000 HIGH CLUTCH PISTON GAUGE

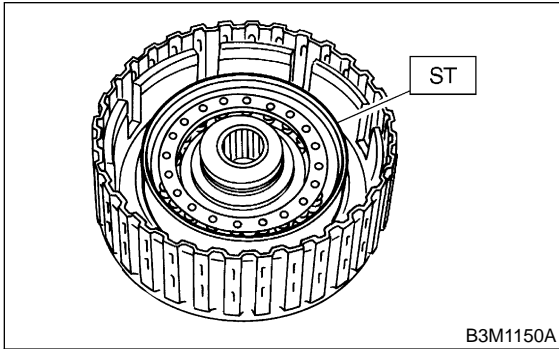

6) Install cover to high clutch piston.

NOTE:

Be careful not to fold over the high clutch piston seal during installation.

7) Using ST1 and ST2, install snap ring.

NOTE:

After installing snap ring, remove STs.

- ST1 398673600 COMPRESSOR
- ST2 498627100 SEAT
- ST3 498437000 HIGH CLUTCH PISTON GAUGE

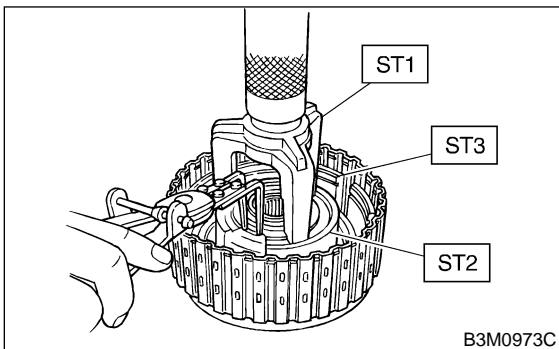

8) Install driven plate, drive plate and retaining plate to high clutch drum.

NOTE:

Install thicker driven plate on the piston side.

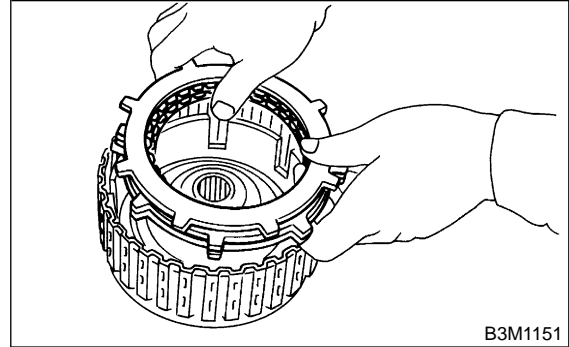

9) Install snap ring to high clutch drum.

10) Apply compressed air intermittently to check for operation.

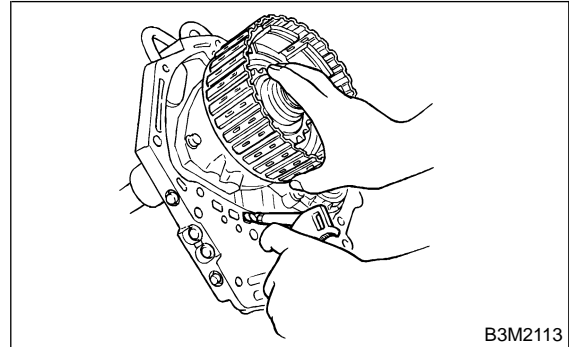

11) Measure the clearance between the retaining plate and snap ring. <Ref. to AT-91, INSPECTION, High Clutch and Reverse Clutch.>

12) Install driven plate, drive plate, retaining plate and snap ring.

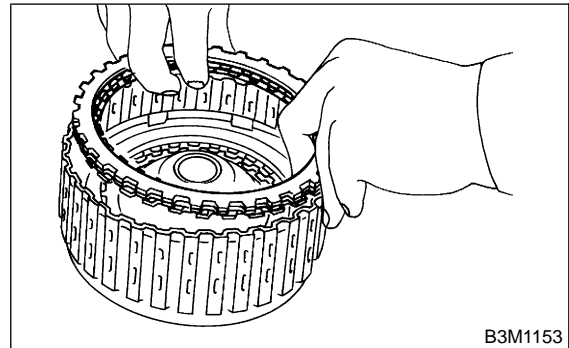

# HIGH CLUTCH AND REVERSE CLUTCH

Automatic Transmission

13) Apply compressed air intermittently to check for operation.

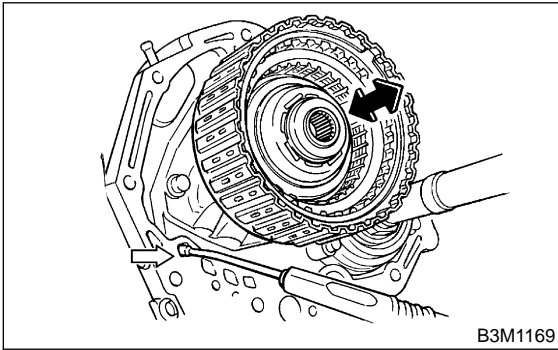

14) Measure the clearance between the retaining plate and snap ring. <Ref. to AT-90, INSPECTION, High Clutch and Reverse Clutch.>

## E: INSPECTION S510213A10

- Drive plate facing for wear and damage
- Snap ring for wear, return spring for setting and breakage, and snap ring retainer for deformation
- Lip seal and lathe cut ring for damage
- Piston and drum check ball for operation
- Adjust total end play. <Ref. to AT-66, ADJUSTMENT, Oil Pump.>

1) Inspect clearance between the retaining plate and snap ring. (High clutch)

### NOTE:

Do not press down retaining plate during clearance measurements.

### Standard value:

**0.8 — 1.1 mm (0.031 — 0.043 in)**

### Allowable limit:

**1.5 mm (0.059 in)**

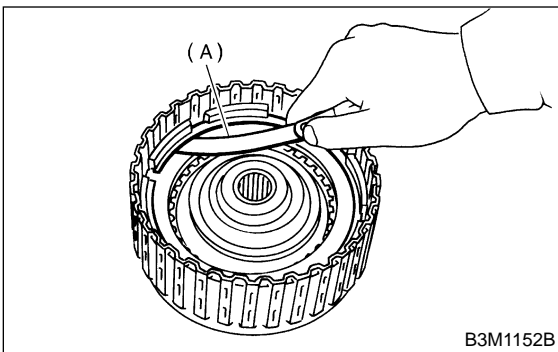

(A) Thickness gauge

If specified tolerance limits are exceeded, select a suitable high clutch retaining plate.

High clutch retaining plate	
Part No.	Thickness mm (in)
31567AA710	4.7 (0.185)
31567AA720	4.8 (0.189)
31567AA730	4.9 (0.193)
31567AA740	5.0 (0.197)
31567AA670	5.1 (0.201)
31567AA680	5.2 (0.205)
31567AA690	5.3 (0.209)
31567AA700	5.4 (0.213)

2) Inspect clearance between retaining plate and snap ring. (Reverse clutch)

### NOTE:

Do not press down retaining plate during clearance measurements.

### Standard value:

**0.5 — 0.8 mm (0.020 — 0.031 in)**

### Allowable limit:

**1.2 mm (0.047 in)**

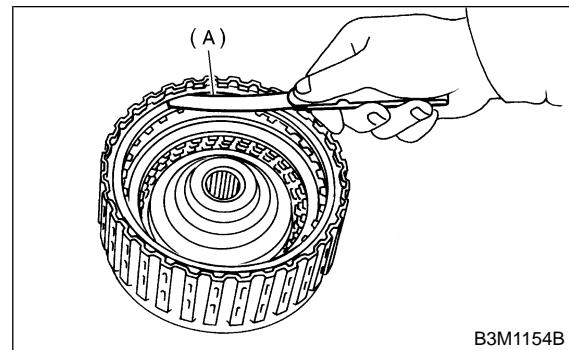

(A) Thickness gauge

If specified tolerance limits are exceeded, select a suitable high clutch retaining plate.

Reverse clutch retaining plates	
Part No.	Thickness mm (in)
31567AA910	4.0 (0.157)
31567AA920	4.2 (0.165)
31567AA930	4.4 (0.173)
31567AA940	4.6 (0.181)
31567AA950	4.8 (0.189)
31567AA960	5.0 (0.197)
31567AA970	5.2 (0.205)
31567AA980	5.4 (0.213)

## 23. Planetary Gear and Low Clutch

S510212

### A: REMOVAL

S510212A18

- 1) Extract the torque converter clutch assembly. <Ref. to AT-35, REMOVAL, Torque Converter Clutch Assembly.>
- 2) Remove the input shaft.

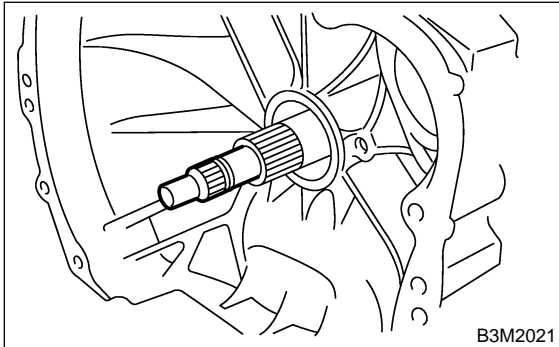

- 3) Disconnect the air breather hose. <Ref. to AT-28, REMOVAL, Air Breather Hose.>
- 4) Disconnect transmission harness connector from stay.

#### NOTE:

Lift-up lever behind the connector and disconnect from stay.

- 5) Disconnect inhibitor switch connector from stay.
- 6) Remove the oil charger pipe, and remove the O-ring from the flange face. Attach the O-ring to the pipe. <Ref. to AT-29, REMOVAL, Oil Charger Pipe.>
- 7) Remove the oil cooler inlet and outlet pipes. <Ref. to AT-30, REMOVAL, Oil Cooler Pipes.>
- 8) Remove rear vehicle speed sensor, and separate the transmission case and extension case. <Ref. to AT-36, REMOVAL, Extension Case.>
- 9) Remove reduction driven gear. WITHOUT VTD <Ref. to AT-48, WITHOUT VTD, REMOVAL, Reduction Driven Gear.> WITH VTD <Ref. to AT-48, WITH VTD, REMOVAL, Reduction Driven Gear.>
- 10) Separation of torque converter clutch case and transmission case. <Ref. to AT-58, REMOVAL, Torque Converter Clutch Case.>
- 11) Remove the oil pump housing. <Ref. to AT-62, REMOVAL, Oil Pump.>
- 12) Take out the high clutch and reverse clutch assembly. <Ref. to AT-87, REMOVAL, High Clutch and Reverse Clutch.>

- 13) Take out the front sun gear and the thrust bearing.

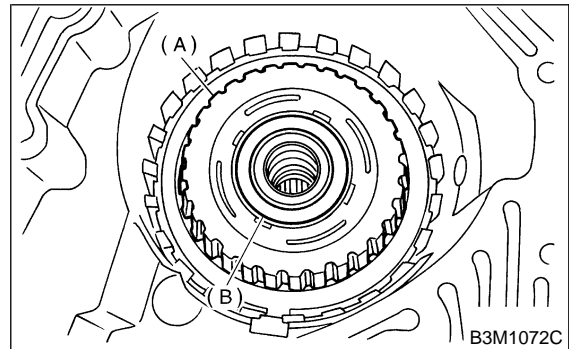

- (A) Front sun gear
- (B) Thrust needle bearing

- 14) Pull out leaf spring.

#### NOTE:

- Be careful not to bend leaf spring during removal.
- Remove it while pressing down on lower leaf spring.

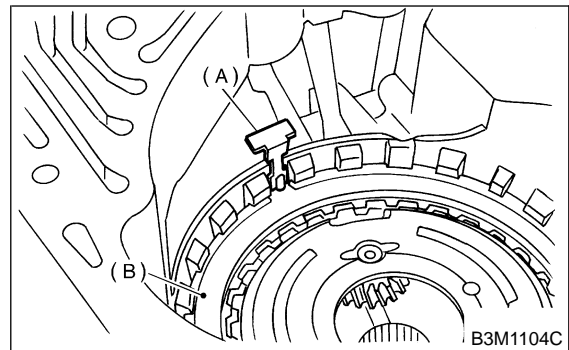

- (A) Leaf spring
- (B) Retaining plate

- 15) Remove snap ring and thrust needle bearing.

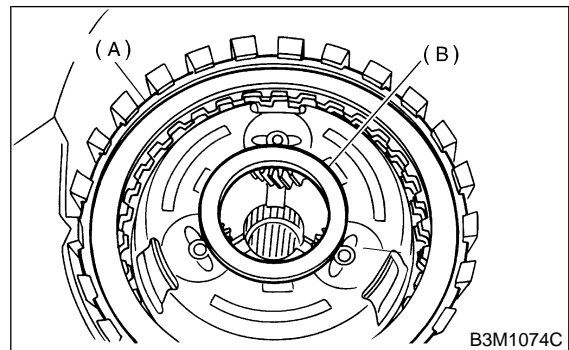

- (A) Snap ring
- (B) Thrust needle bearing

16) Take out retaining plate, drive plate and driven plate of 2-4 brake.

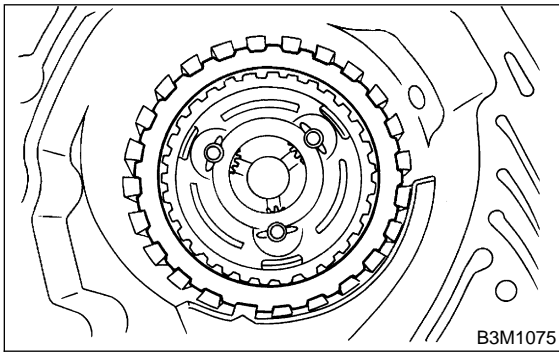

17) Take out the thrust needle bearing, planetary gear assembly and the low clutch assembly.

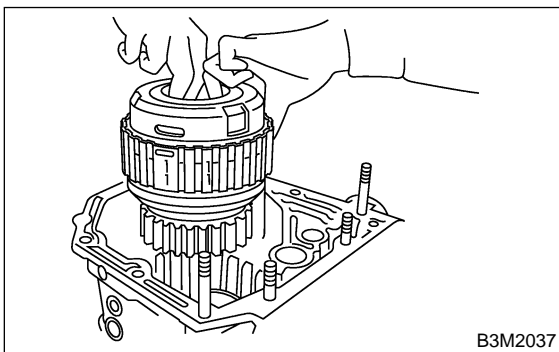

## B: INSTALLATION S510212A11

1) Install planetary gear and low clutch assembly to transmission case.

Install carefully while rotating the low clutch and planetary gear assembly slowly paying special attention not to damage the seal ring.

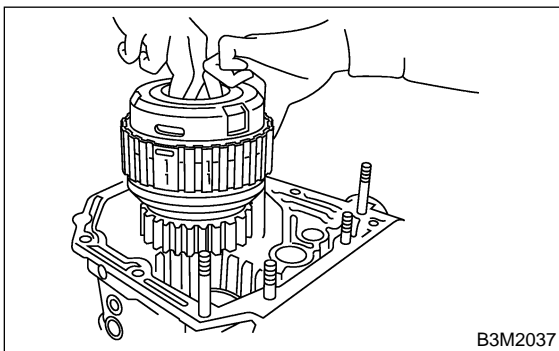

2) Install leaf spring of 2-4 brake.

NOTE:

Be careful not to mistake the location of the leaf spring to be inserted.

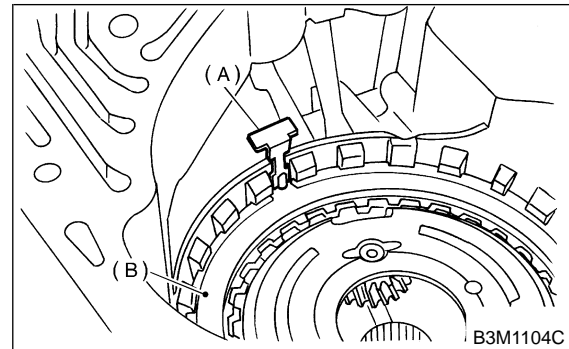

- (A) Leaf spring
- (B) Retaining plate

3) Install thrust needle bearing and snap ring.

NOTE:

Install thrust needle bearing in the correct direction.

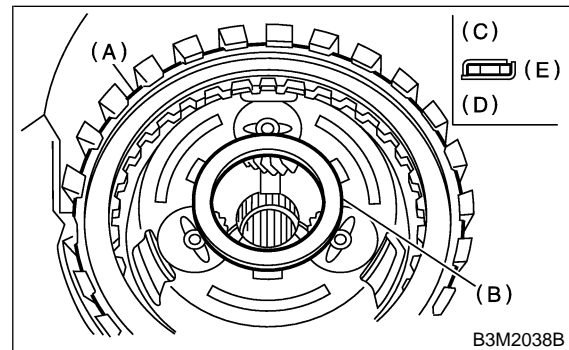

- (A) Snap ring
- (B) Thrust needle bearing
- (C) Up side
- (D) Down side
- (E) Outside

4) Install front sun gear and thrust needle bearing.  
5) Install the high clutch hub and thrust needle bearing.

Attach the thrust needle bearing to the hub with vaseline and install the hub by correctly engaging the splines of the front planetary carrier.

NOTE:

Install thrust needle bearing in the correct direction.

# PLANETARY GEAR AND LOW CLUTCH

Automatic Transmission

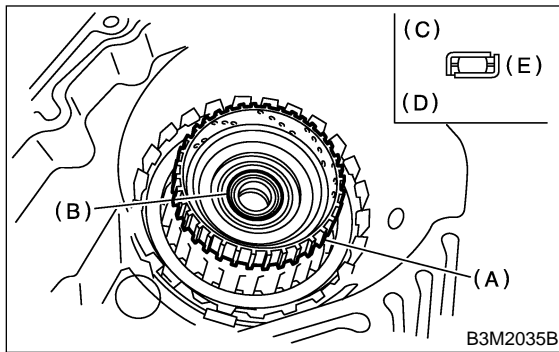

- (A) High clutch hub
- (B) Thrust needle bearing
- (C) Up side
- (D) Down side
- (E) Outside

6) Install the high clutch assembly.

### NOTE:

Correctly engage the high clutch hub and clutch splines.

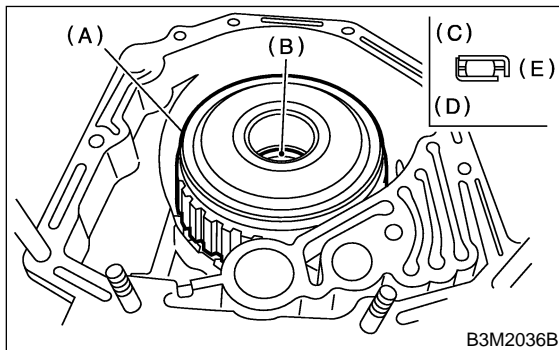

- (A) High clutch and reverse clutch assembly
- (B) Thrust needle bearing
- (C) Up side
- (D) Down side
- (E) Outside

7) Install oil pump housing assembly with gasket.  
8) Install torque converter clutch case. <Ref. to AT-59, INSTALLATION, Torque Converter Clutch Case.>

9) Insert inhibitor switch and transmission connector into stay.

10) Install air breather hose. <Ref. to AT-28, INSTALLATION, Air Breather Hose.>

11) Install oil cooler pipes. <Ref. to AT-30, INSTALLATION, Oil Cooler Pipes.>

12) Install the oil charger pipe with O-ring. <Ref. to AT-29, INSTALLATION, Oil Charger Pipe.>

13) Insert the input shaft while turning lightly by hand.

### CAUTION:

Be careful not to damage the bushing.

Normal protrusion A:  
50 — 55 mm (1.97 — 2.17 in)

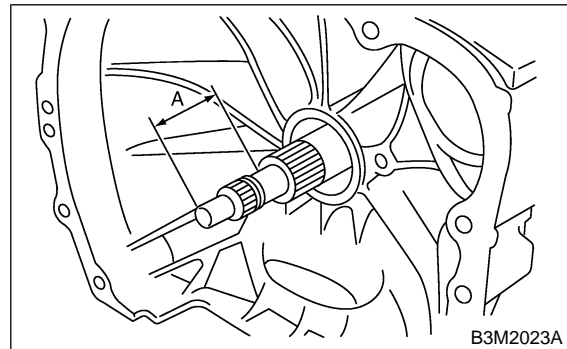

14) Install the torque converter clutch assembly. <Ref. to AT-35, INSTALLATION, Torque Converter Clutch Assembly.>

### C: DISASSEMBLY S510212A06

1) Remove snap ring from the low clutch drum.

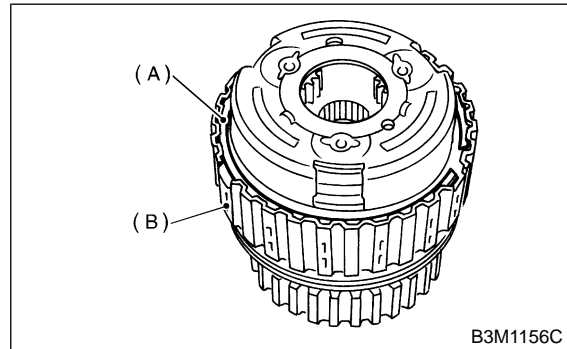

- (A) Snap ring
- (B) Low clutch drum

2) Take out front planetary carrier.

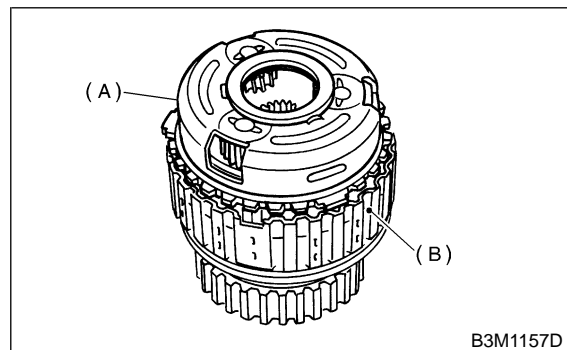

- (A) Front planetary carrier
- (B) Low clutch drum

3) Take out rear sun gear.

# PLANETARY GEAR AND LOW CLUTCH

Automatic Transmission

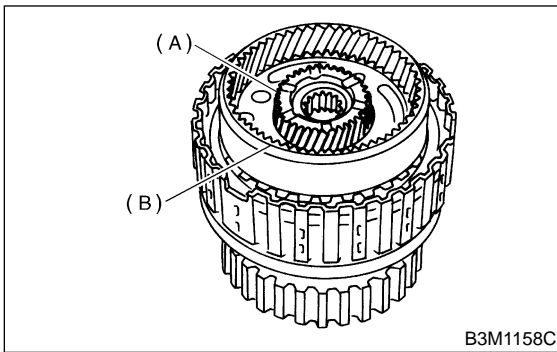

- (A) Rear sun gear
- (B) Rear planetary carrier

4) Take out rear planetary carrier, washer and thrust needle bearing.

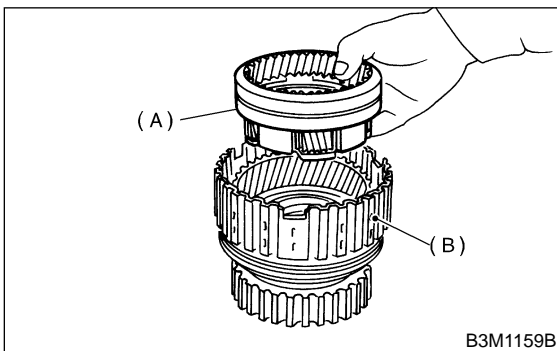

- (A) Rear planetary carrier
- (B) Low clutch drum

5) Take out rear internal gear.

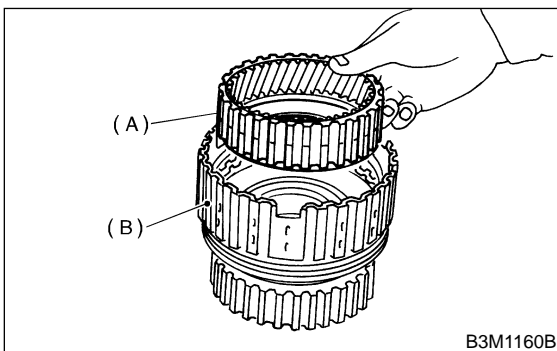

- (A) Rear internal gear
- (B) Low clutch drum

6) Remove the snap ring from the low clutch drum.

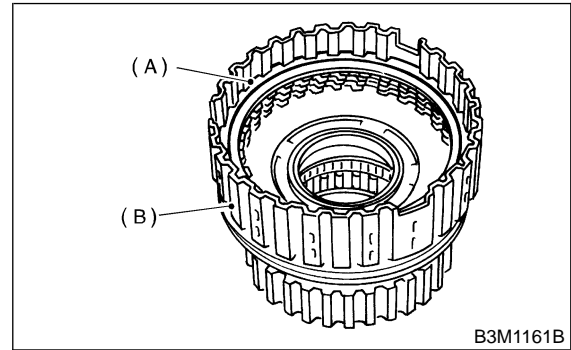

- (A) Snap ring
- (B) Low clutch drum

7) Compress the spring retainer, and remove the snap ring from the low clutch drum, by using ST1 and ST2.

ST1 498627100 SEAT  
ST2 398673600 COMPRESSOR

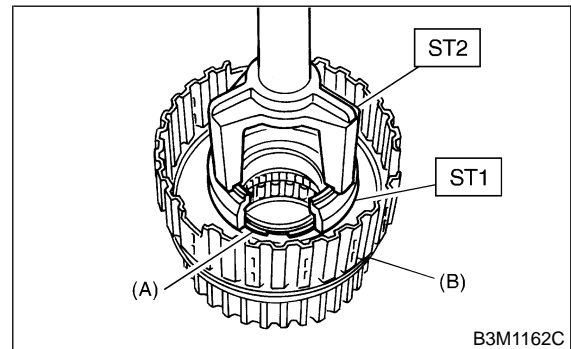

- (A) Snap ring
- (B) Low clutch drum

8) Remove one-way clutch. <Ref. to AT-104, REMOVAL, One-way Clutch.>

Install the one-way clutch inner race to the low clutch drum, and apply compressed air to remove the low clutch piston.

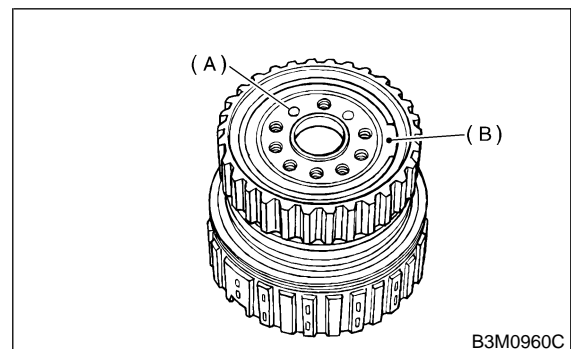

- (A) Apply compressed air
- (B) One-way clutch inner race

9) Remove the one-way clutch inner race.



# PLANETARY GEAR AND LOW CLUTCH

Automatic Transmission

10) Remove the one-way clutch after taking out the snap ring.

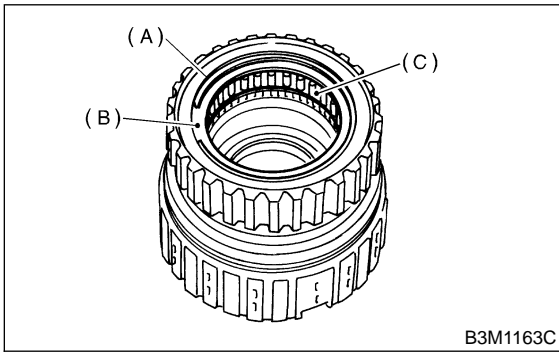

- (A) Snap ring
- (B) Plate
- (C) One-way clutch

11) Remove the needle bearing after taking out the snap ring.

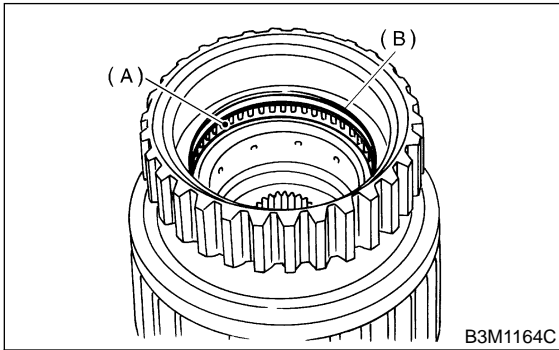

- (A) Needle bearing
- (B) Snap ring

## D: ASSEMBLY S510212A02

- 1) Install lathe cut seal ring to low clutch piston.
- 2) Fit the low clutch piston to the low clutch drum.

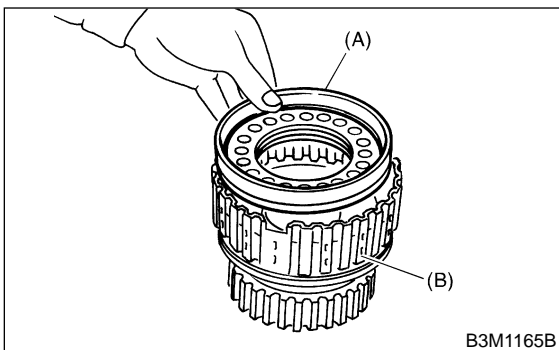

- (A) Low clutch piston
- (B) Low clutch drum

3) Install spring retainer to low clutch piston.

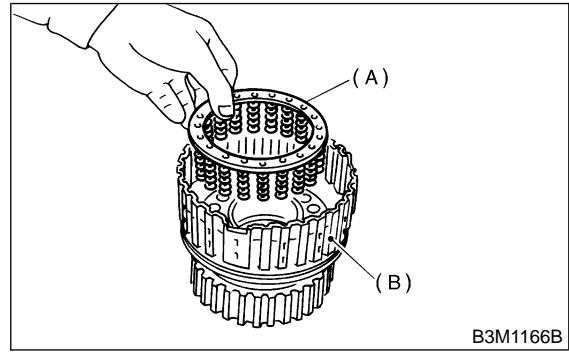

- (A) Spring retainer
- (B) Low clutch drum

4) Install ST to low clutch drum.  
ST 498437100 LOW CLUTCH PISTON GUIDE

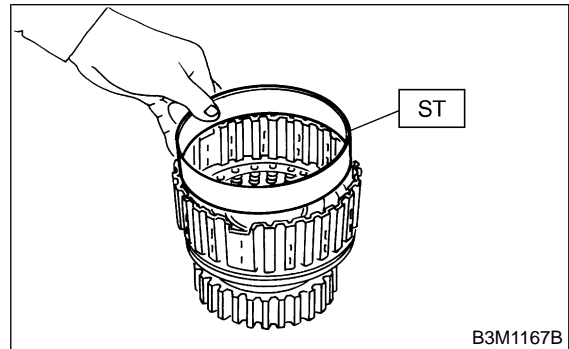

5) Set the cover on the piston with a press using ST1 and ST2, and attach the snap ring.

### NOTE:

- Be careful not to fold cover seal during installation.
- After installing snap ring, remove ST1, ST2 and ST3.

ST1 498627100 SEAT  
ST2 398673600 COMPRESSOR  
ST3 498437100 LOW CLUTCH PISTON GUIDE

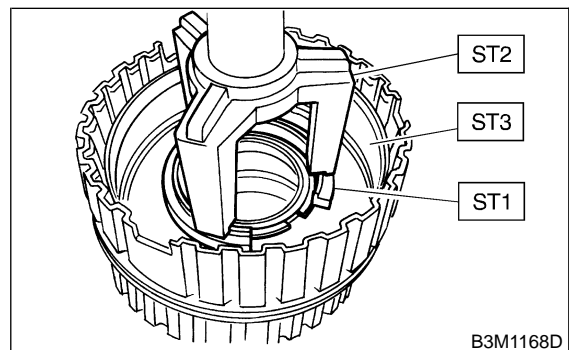

6) Install the dish plate, driven plates, drive plates, and retaining plate, and secure with the snap ring.

**NOTE:**

Pay attention to the orientation of the dish plate.

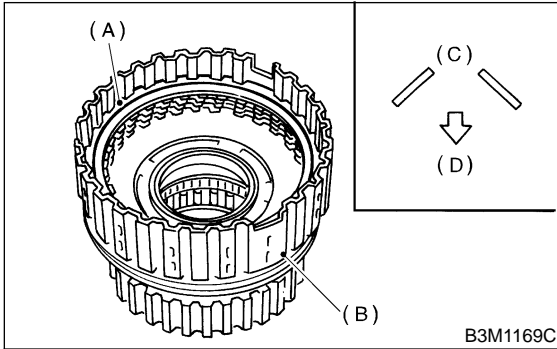

- (A) Snap ring
- (B) Low clutch drum
- (C) Dish plate
- (D) Low clutch piston side

7) Check the low clutch for operation.

- (1) Remove one-way clutch. <Ref. to AT-104, REMOVAL, One-way Clutch.>
- (2) Set the one-way clutch inner race, and apply compressed air for checking.

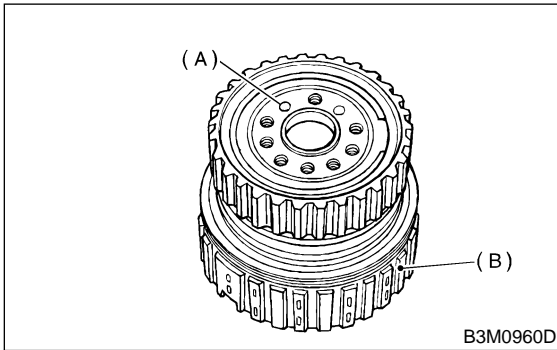

- (A) Apply compressed air
- (B) Low clutch drum

8) Checking low clutch clearance. <Ref. to AT-99, INSPECTION, Planetary Gear and Low Clutch.>

9) Install washer to rear internal gear.

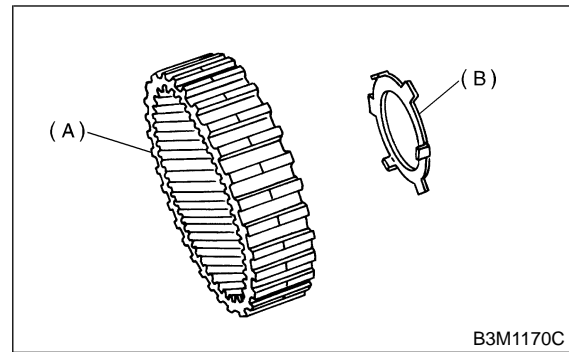

- (A) Rear internal gear
- (B) Washer

10) Install rear internal gear.

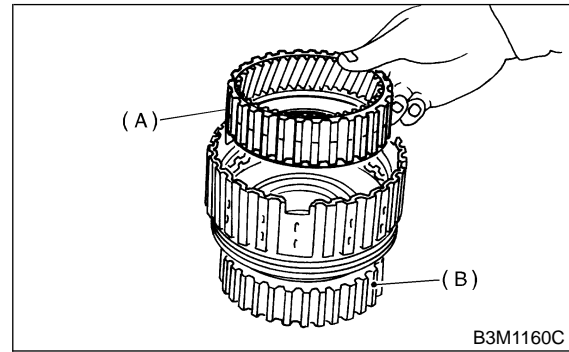

- (A) Rear internal gear
- (B) Low clutch drum

11) Install thrust needle bearing.

**NOTE:**

Install thrust needle bearing in the correct direction.

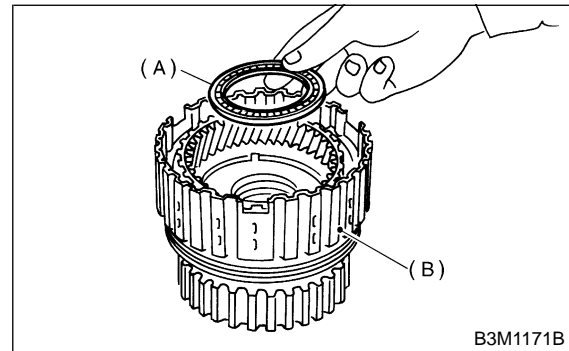

- (A) Thrust needle bearing
- (B) Low clutch drum

12) Install washer to rear planetary carrier.

**NOTE:**

Make sure washer tooth is inserted into hole on planetary carrier.

# PLANETARY GEAR AND LOW CLUTCH

Automatic Transmission

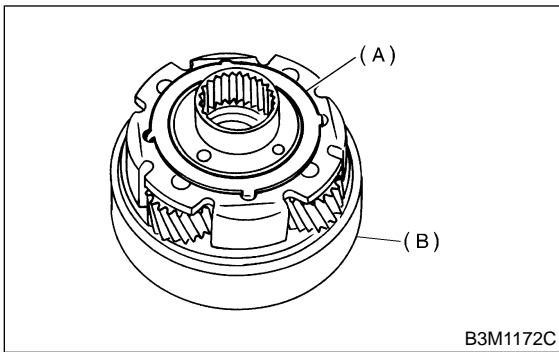

- (A) Washer
- (B) Rear planetary carrier

13) Install rear planetary carrier to low clutch drum.

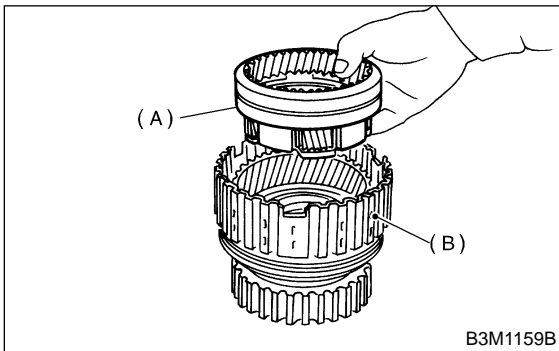

- (A) Rear planetary carrier
- (B) Low clutch drum

14) Install thrust needle bearing to rear planetary carrier.

**NOTE:**  
Install thrust needle bearing in the correct direction.

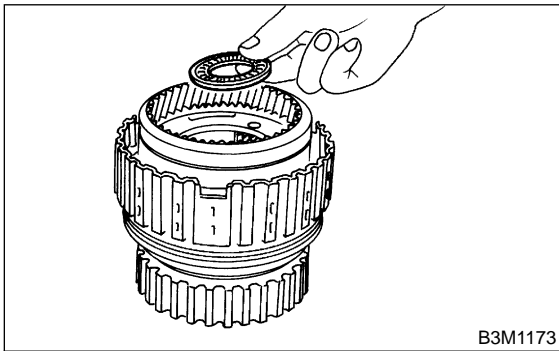

15) Install rear sun gear.

**NOTE:**  
Pay attention to the orientation of the rear sun gear.

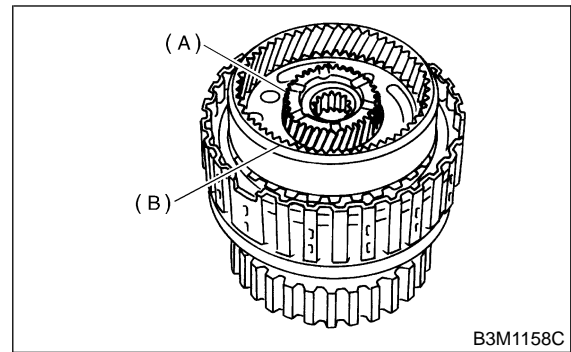

- (A) Rear sun gear
- (B) Rear planetary carrier

16) Install thrust needle bearing to front planetary carrier.

**NOTE:**  
Pay attention to the orientation of the thrust needle bearing.

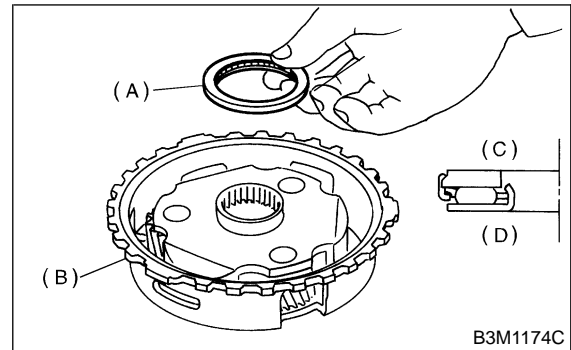

- (A) Thrust needle bearing
- (B) Front planetary carrier
- (C) Rear sun gear side
- (D) Front planetary carrier side

17) Install front planetary carrier to low clutch drum.

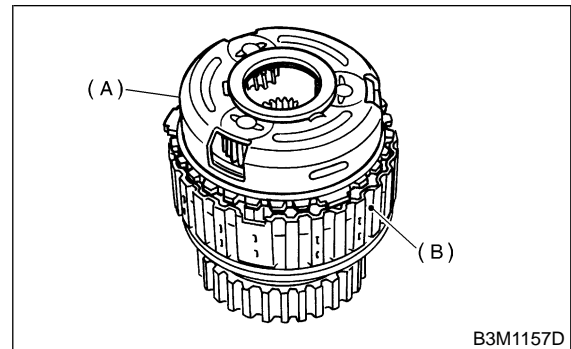

- (A) Front planetary carrier
- (B) Low clutch drum

18) Install snap ring to low clutch drum.

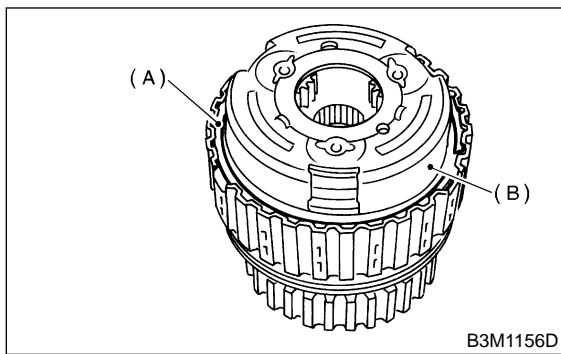

- (A) Snap ring
- (B) Front planetary carrier

19) Install the needle bearing, and secure with the snap ring.

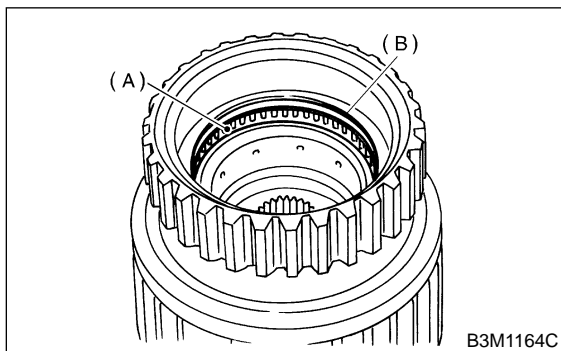

- (A) Needle bearing
- (B) Snap ring

20) Install the one-way clutch, one-way clutch inner race and plate, and secure with the snap ring.

**NOTE:**

Set the inner race. Make sure that the forward clutch is free in the clockwise direction and locked in the counterclockwise direction, as viewed from the front of the vehicle.

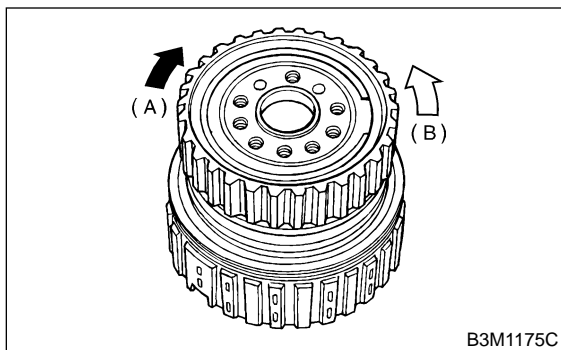

- (A) Locked
- (B) Free

**E: INSPECTION** S510212A10

- Drive plate facing for wear and damage
- Snap ring for wear, return spring for breakage or setting, and spring retainer for deformation

- Lip seal and lathe cut seal ring for damage
- Piston check ball for operation
- Measure the total end play and adjust to within specifications.

<Ref. to AT-66, ADJUSTMENT, Oil Pump.>

1) Inspect clearance between retaining plate and operation of the low clutch.

**NOTE:**

Before measuring clearance, place the same thickness of shim on both sides to prevent retaining plate from tilting.

**Standard value:**

**0.7 — 1.1 mm (0.028 — 0.043 in)**

**Allowable limit:**

**1.6 mm (0.063 in)**

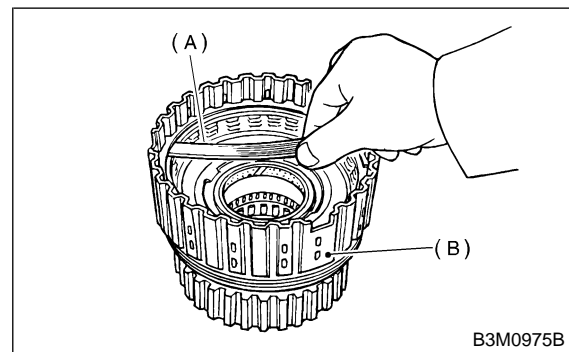

- (A) Thickness gauge
- (B) Low clutch drum

If the clearance is out of the specified range, select a proper retaining plate so that the standard clearance can be obtained.

Available retaining plates	
Part No.	Thickness mm (in)
31567AA830	3.8 (0.150)
31567AA840	4.0 (0.157)
31567AA850	4.2 (0.165)
31567AA860	4.4 (0.173)
31567AA870	4.6 (0.181)

## 23. Planetary Gear and Low Clutch

S510212

### A: REMOVAL

S510212A18

- 1) Extract the torque converter clutch assembly. <Ref. to AT-35, REMOVAL, Torque Converter Clutch Assembly.>
- 2) Remove the input shaft.

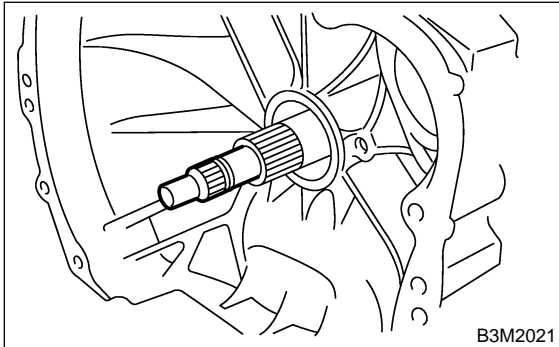

- 3) Disconnect the air breather hose. <Ref. to AT-28, REMOVAL, Air Breather Hose.>
- 4) Disconnect transmission harness connector from stay.

**NOTE:**

Lift-up lever behind the connector and disconnect from stay.

- 5) Disconnect inhibitor switch connector from stay.
- 6) Remove the oil charger pipe, and remove the O-ring from the flange face. Attach the O-ring to the pipe. <Ref. to AT-29, REMOVAL, Oil Charger Pipe.>
- 7) Remove the oil cooler inlet and outlet pipes. <Ref. to AT-30, REMOVAL, Oil Cooler Pipes.>
- 8) Remove rear vehicle speed sensor, and separate the transmission case and extension case. <Ref. to AT-36, REMOVAL, Extension Case.>
- 9) Remove reduction driven gear.  
WITHOUT VTD <Ref. to AT-48, WITHOUT VTD, REMOVAL, Reduction Driven Gear.>  
WITH VTD <Ref. to AT-48, WITH VTD, REMOVAL, Reduction Driven Gear.>
- 10) Separation of torque converter clutch case and transmission case. <Ref. to AT-58, REMOVAL, Torque Converter Clutch Case.>
- 11) Remove the oil pump housing. <Ref. to AT-62, REMOVAL, Oil Pump.>
- 12) Take out the high clutch and reverse clutch assembly. <Ref. to AT-87, REMOVAL, High Clutch and Reverse Clutch.>

- 13) Take out the front sun gear and the thrust bearing.

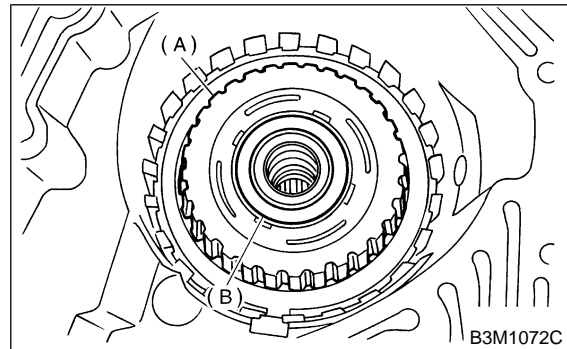

- (A) Front sun gear
- (B) Thrust needle bearing

- 14) Pull out leaf spring.

**NOTE:**

- Be careful not to bend leaf spring during removal.
- Remove it while pressing down on lower leaf spring.

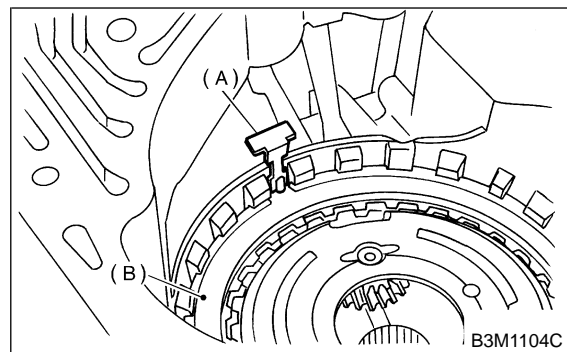

- (A) Leaf spring
- (B) Retaining plate

- 15) Remove snap ring and thrust needle bearing.

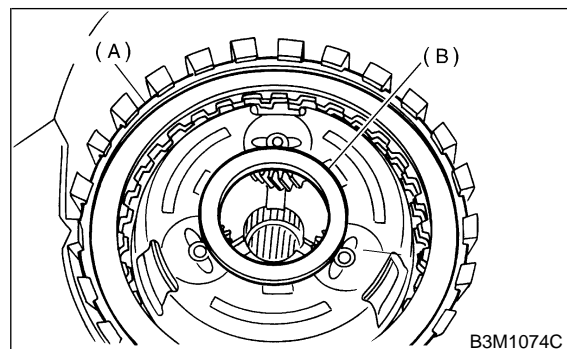

- (A) Snap ring
- (B) Thrust needle bearing

16) Take out retaining plate, drive plate and driven plate of 2-4 brake.

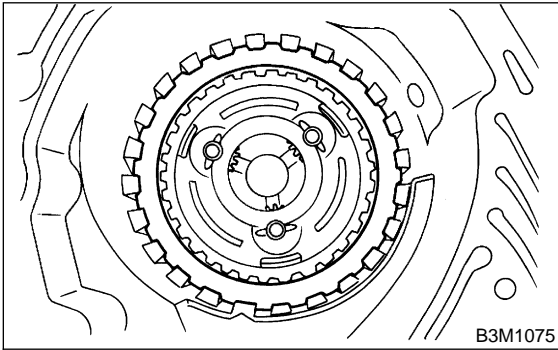

17) Take out the thrust needle bearing, planetary gear assembly and the low clutch assembly.

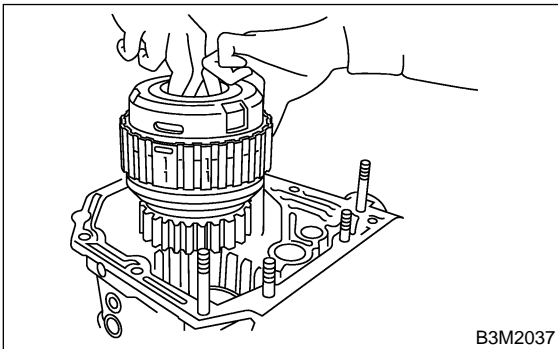

2) Install leaf spring of 2-4 brake.

NOTE:

Be careful not to mistake the location of the leaf spring to be inserted.

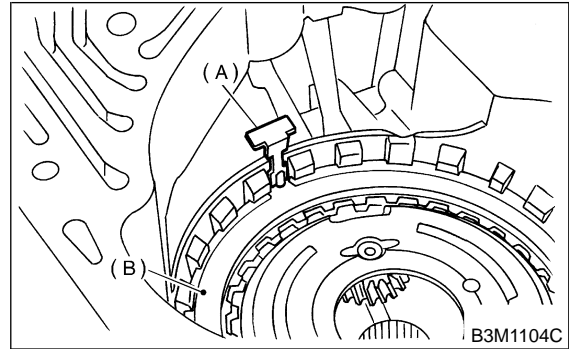

- (A) Leaf spring
- (B) Retaining plate

3) Install thrust needle bearing and snap ring.

NOTE:

Install thrust needle bearing in the correct direction.

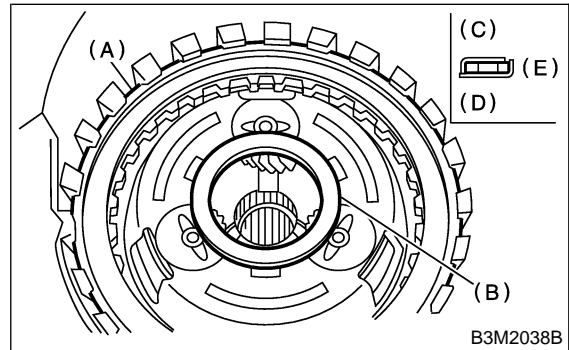

- (A) Snap ring
- (B) Thrust needle bearing
- (C) Up side
- (D) Down side
- (E) Outside

## B: INSTALLATION

S510212A11

1) Install planetary gear and low clutch assembly to transmission case.

Install carefully while rotating the low clutch and planetary gear assembly slowly paying special attention not to damage the seal ring.

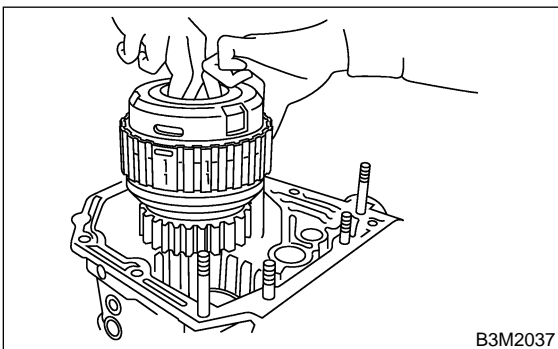

4) Install front sun gear and thrust needle bearing.  
5) Install the high clutch hub and thrust needle bearing.

Attach the thrust needle bearing to the hub with vaseline and install the hub by correctly engaging the splines of the front planetary carrier.

NOTE:

Install thrust needle bearing in the correct direction.

# PLANETARY GEAR AND LOW CLUTCH

Automatic Transmission

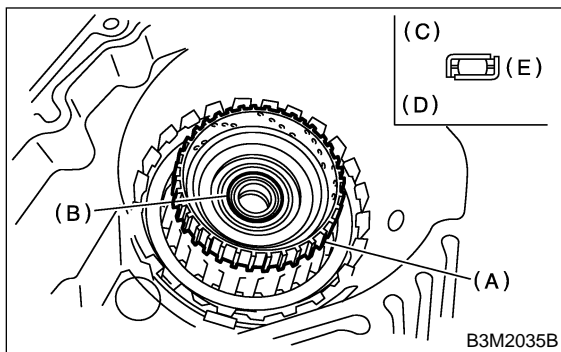

- (A) High clutch hub
- (B) Thrust needle bearing
- (C) Up side
- (D) Down side
- (E) Outside

6) Install the high clutch assembly.

**NOTE:**

Correctly engage the high clutch hub and clutch splines.

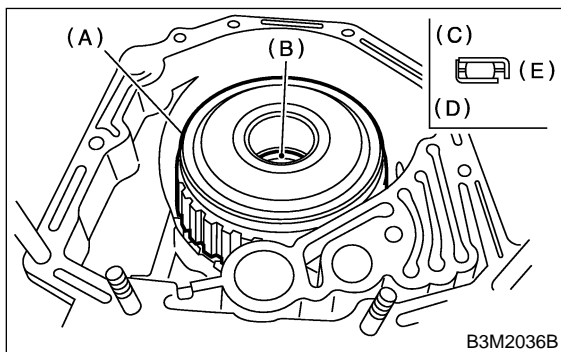

- (A) High clutch and reverse clutch assembly
- (B) Thrust needle bearing
- (C) Up side
- (D) Down side
- (E) Outside

7) Install oil pump housing assembly with gasket.  
 8) Install torque converter clutch case. <Ref. to AT-59, INSTALLATION, Torque Converter Clutch Case.>

9) Insert inhibitor switch and transmission connector into stay.

10) Install air breather hose. <Ref. to AT-28, INSTALLATION, Air Breather Hose.>

11) Install oil cooler pipes. <Ref. to AT-30, INSTALLATION, Oil Cooler Pipes.>

12) Install the oil charger pipe with O-ring. <Ref. to AT-29, INSTALLATION, Oil Charger Pipe.>

13) Insert the input shaft while turning lightly by hand.

**CAUTION:**

Be careful not to damage the bushing.

**Normal protrusion A:**  
 50 — 55 mm (1.97 — 2.17 in)

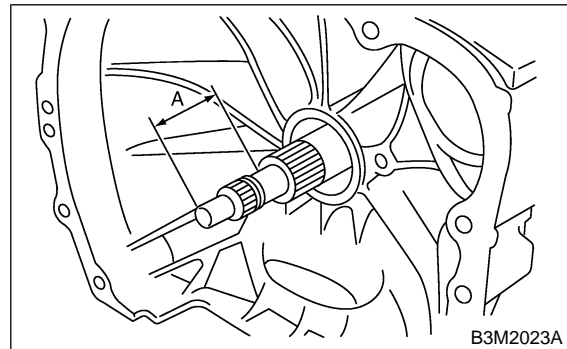

14) Install the torque converter clutch assembly. <Ref. to AT-35, INSTALLATION, Torque Converter Clutch Assembly.>

**C: DISASSEMBLY** S510212A06

1) Remove snap ring from the low clutch drum.

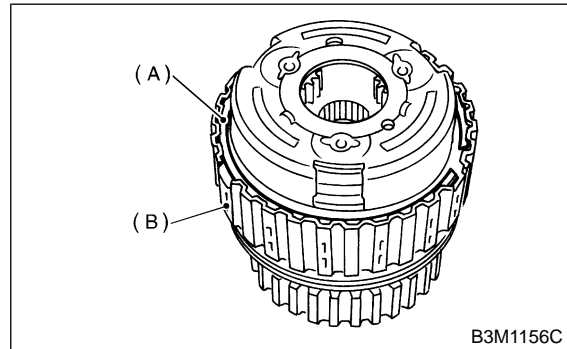

- (A) Snap ring
- (B) Low clutch drum

2) Take out front planetary carrier.

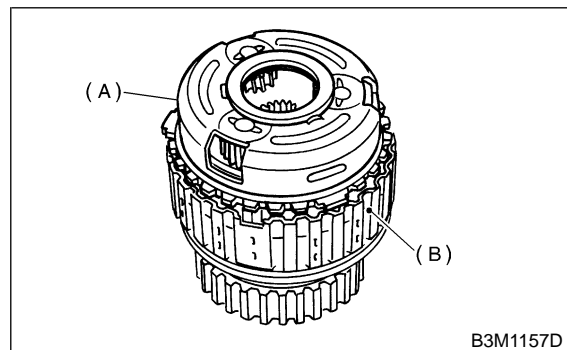

- (A) Front planetary carrier
- (B) Low clutch drum

3) Take out rear sun gear.

# PLANETARY GEAR AND LOW CLUTCH

Automatic Transmission

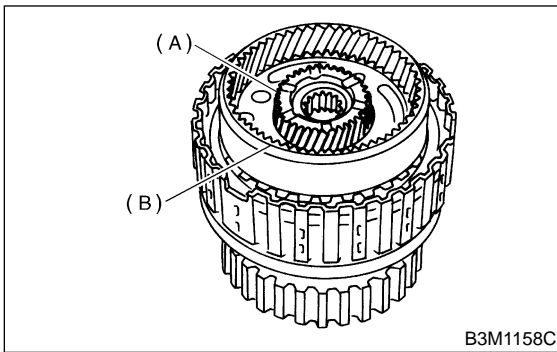

- (A) Rear sun gear
- (B) Rear planetary carrier

4) Take out rear planetary carrier, washer and thrust needle bearing.

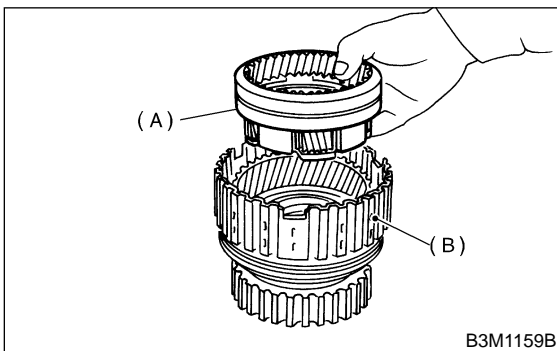

- (A) Rear planetary carrier
- (B) Low clutch drum

5) Take out rear internal gear.

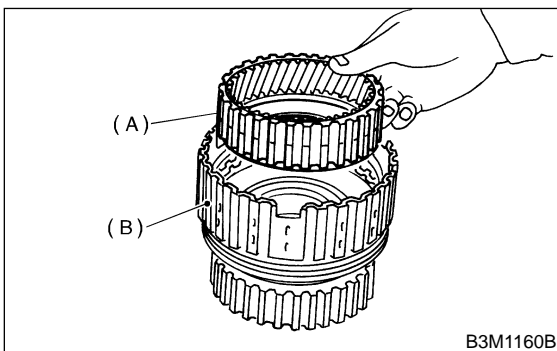

- (A) Rear internal gear
- (B) Low clutch drum

6) Remove the snap ring from the low clutch drum.

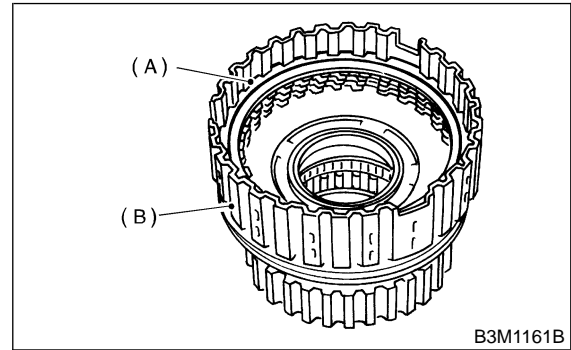

- (A) Snap ring
- (B) Low clutch drum

7) Compress the spring retainer, and remove the snap ring from the low clutch drum, by using ST1 and ST2.

ST1 498627100 SEAT  
ST2 398673600 COMPRESSOR

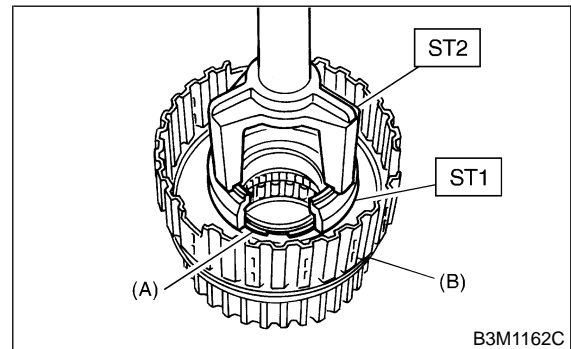

- (A) Snap ring
- (B) Low clutch drum

8) Remove one-way clutch. <Ref. to AT-104, REMOVAL, One-way Clutch.>

Install the one-way clutch inner race to the low clutch drum, and apply compressed air to remove the low clutch piston.

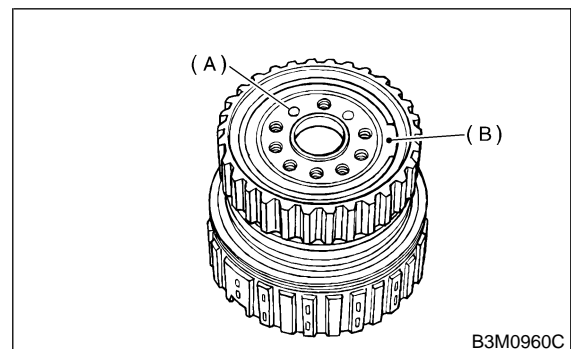

- (A) Apply compressed air
- (B) One-way clutch inner race

9) Remove the one-way clutch inner race.



# PLANETARY GEAR AND LOW CLUTCH

Automatic Transmission

10) Remove the one-way clutch after taking out the snap ring.

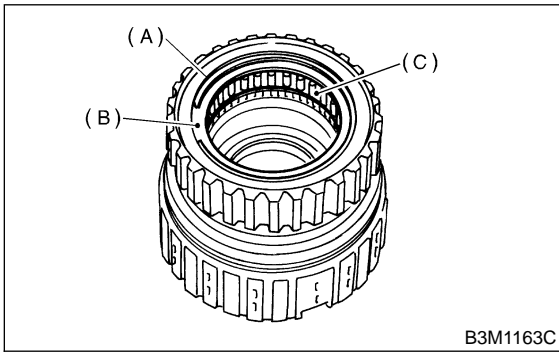

- (A) Snap ring
- (B) Plate
- (C) One-way clutch

11) Remove the needle bearing after taking out the snap ring.

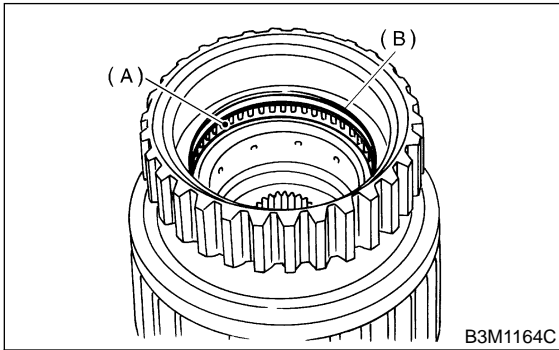

- (A) Needle bearing
- (B) Snap ring

## D: ASSEMBLY S510212A02

- 1) Install lathe cut seal ring to low clutch piston.
- 2) Fit the low clutch piston to the low clutch drum.

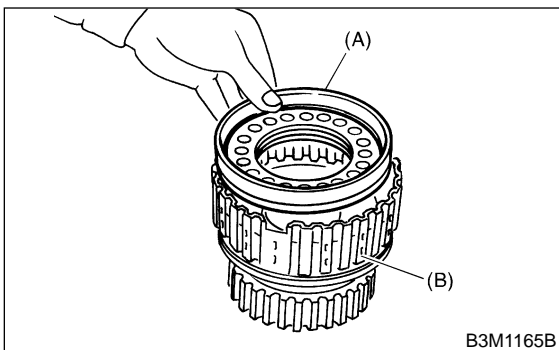

- (A) Low clutch piston
- (B) Low clutch drum

3) Install spring retainer to low clutch piston.

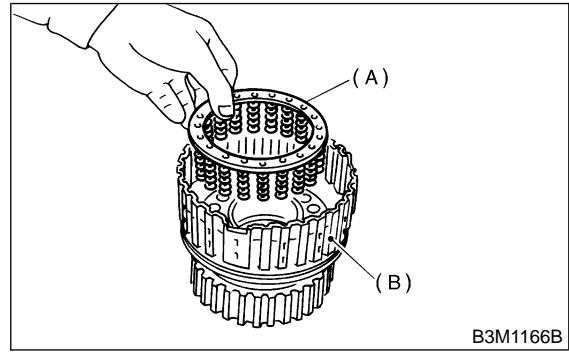

- (A) Spring retainer
- (B) Low clutch drum

4) Install ST to low clutch drum.  
ST 498437100 LOW CLUTCH PISTON GUIDE

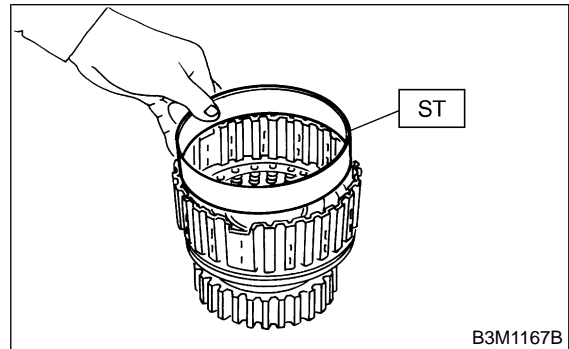

5) Set the cover on the piston with a press using ST1 and ST2, and attach the snap ring.

### NOTE:

- Be careful not to fold cover seal during installation.
- After installing snap ring, remove ST1, ST2 and ST3.

ST1 498627100 SEAT  
ST2 398673600 COMPRESSOR  
ST3 498437100 LOW CLUTCH PISTON GUIDE

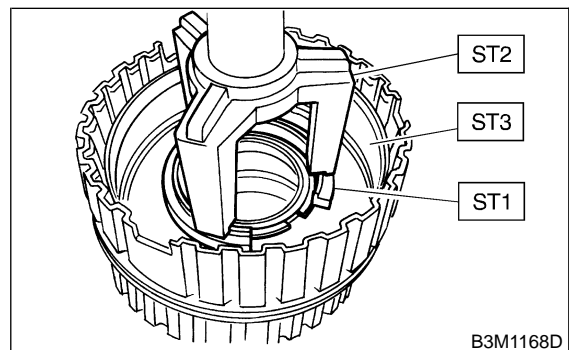

6) Install the dish plate, driven plates, drive plates, and retaining plate, and secure with the snap ring.

**NOTE:**

Pay attention to the orientation of the dish plate.

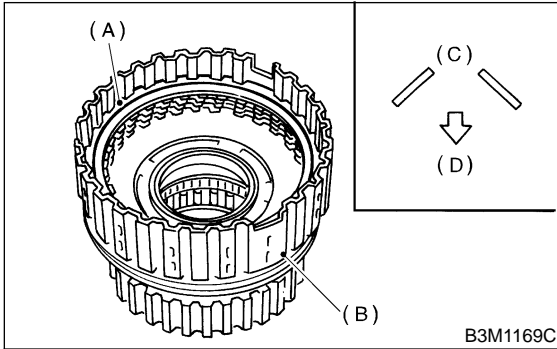

- (A) Snap ring
- (B) Low clutch drum
- (C) Dish plate
- (D) Low clutch piston side

7) Check the low clutch for operation.

(1) Remove one-way clutch. <Ref. to AT-104, REMOVAL, One-way Clutch.>

(2) Set the one-way clutch inner race, and apply compressed air for checking.

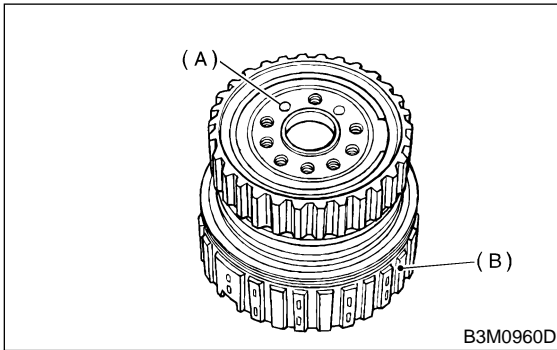

- (A) Apply compressed air
- (B) Low clutch drum

8) Checking low clutch clearance. <Ref. to AT-99, INSPECTION, Planetary Gear and Low Clutch.>

9) Install washer to rear internal gear.

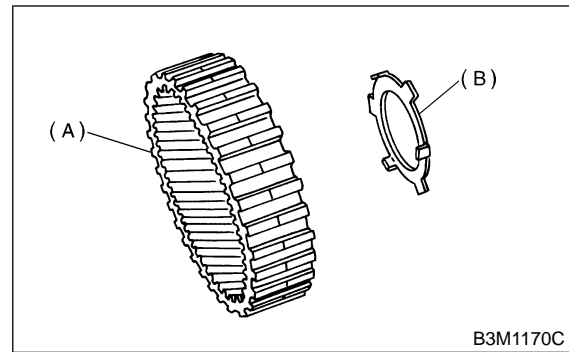

- (A) Rear internal gear
- (B) Washer

10) Install rear internal gear.

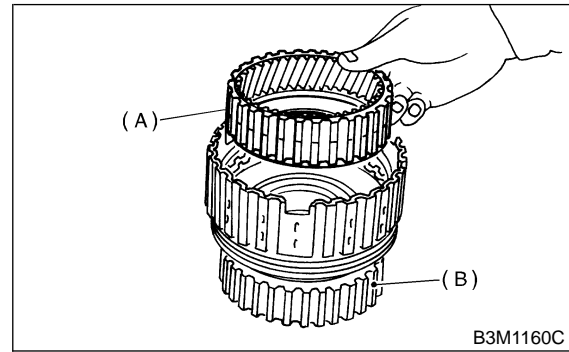

- (A) Rear internal gear
- (B) Low clutch drum

11) Install thrust needle bearing.

**NOTE:**

Install thrust needle bearing in the correct direction.

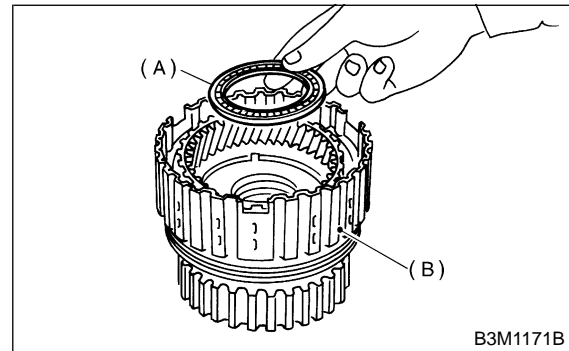

- (A) Thrust needle bearing
- (B) Low clutch drum

12) Install washer to rear planetary carrier.

**NOTE:**

Make sure washer tooth is inserted into hole on planetary carrier.

# PLANETARY GEAR AND LOW CLUTCH

Automatic Transmission

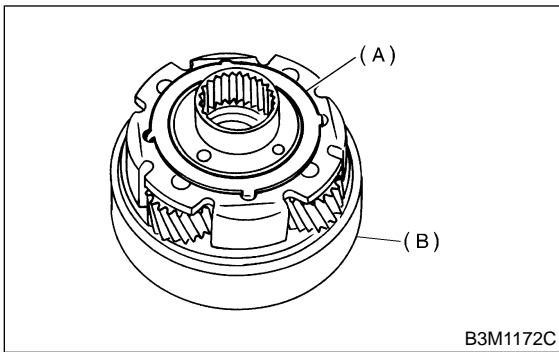

- (A) Washer
- (B) Rear planetary carrier

13) Install rear planetary carrier to low clutch drum.

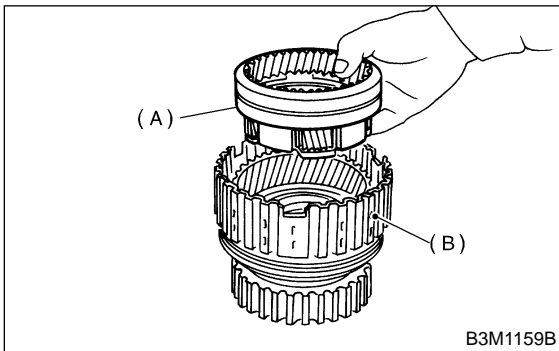

- (A) Rear planetary carrier
- (B) Low clutch drum

14) Install thrust needle bearing to rear planetary carrier.

**NOTE:**  
Install thrust needle bearing in the correct direction.

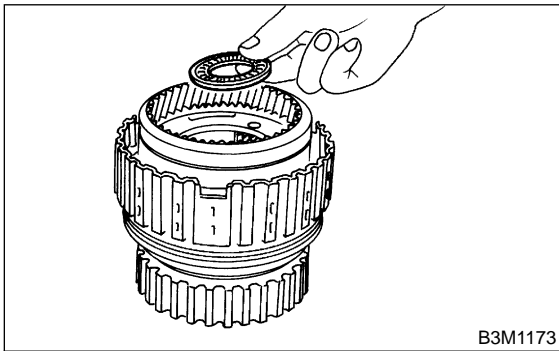

15) Install rear sun gear.

**NOTE:**  
Pay attention to the orientation of the rear sun gear.

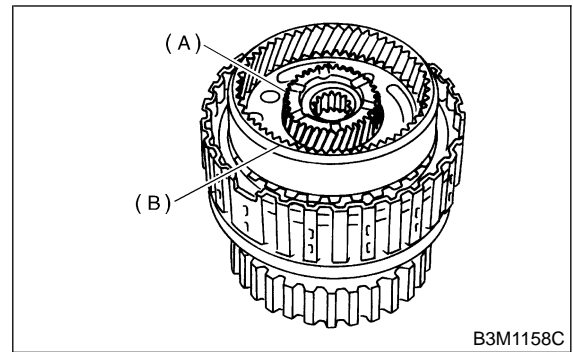

- (A) Rear sun gear
- (B) Rear planetary carrier

16) Install thrust needle bearing to front planetary carrier.

**NOTE:**  
Pay attention to the orientation of the thrust needle bearing.

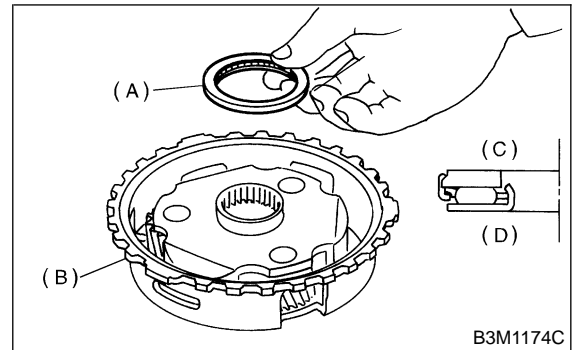

- (A) Thrust needle bearing
- (B) Front planetary carrier
- (C) Rear sun gear side
- (D) Front planetary carrier side

17) Install front planetary carrier to low clutch drum.

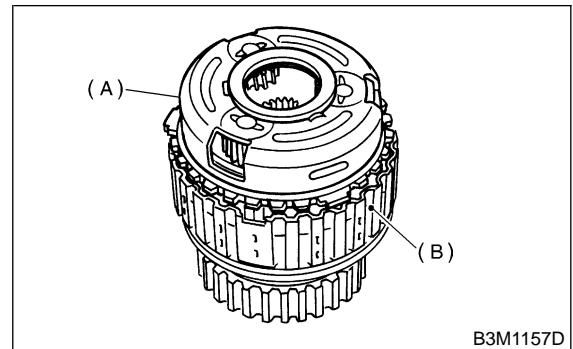

- (A) Front planetary carrier
- (B) Low clutch drum

18) Install snap ring to low clutch drum.

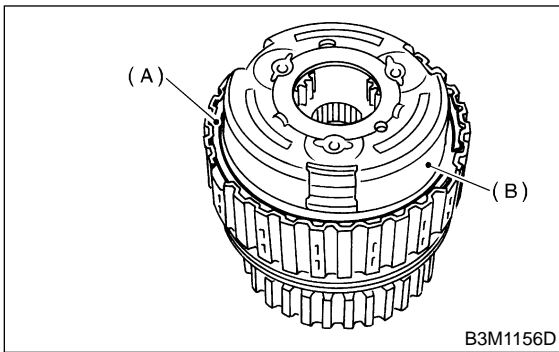

- (A) Snap ring
- (B) Front planetary carrier

19) Install the needle bearing, and secure with the snap ring.

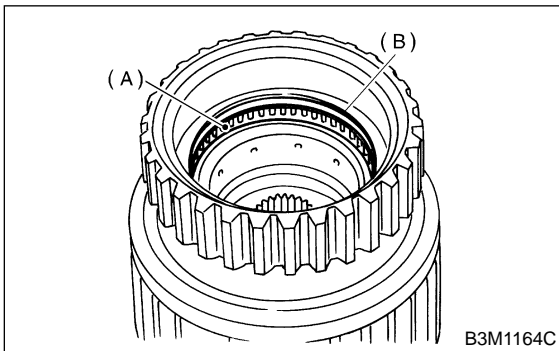

- (A) Needle bearing
- (B) Snap ring

20) Install the one-way clutch, one-way clutch inner race and plate, and secure with the snap ring.

**NOTE:**

Set the inner race. Make sure that the forward clutch is free in the clockwise direction and locked in the counterclockwise direction, as viewed from the front of the vehicle.

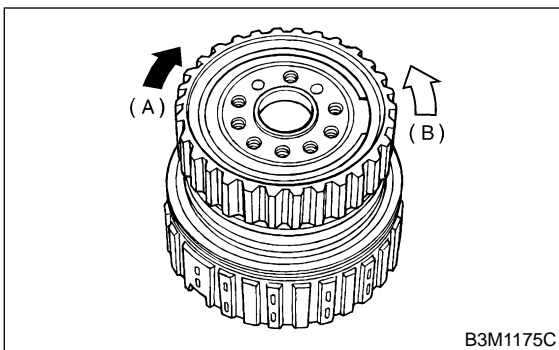

- (A) Locked
- (B) Free

**E: INSPECTION** S510212A10

- Drive plate facing for wear and damage
- Snap ring for wear, return spring for breakage or setting, and spring retainer for deformation

- Lip seal and lathe cut seal ring for damage
- Piston check ball for operation
- Measure the total end play and adjust to within specifications.

<Ref. to AT-66, ADJUSTMENT, Oil Pump.>

1) Inspect clearance between retaining plate and operation of the low clutch.

**NOTE:**

Before measuring clearance, place the same thickness of shim on both sides to prevent retaining plate from tilting.

**Standard value:**

**0.7 — 1.1 mm (0.028 — 0.043 in)**

**Allowable limit:**

**1.6 mm (0.063 in)**

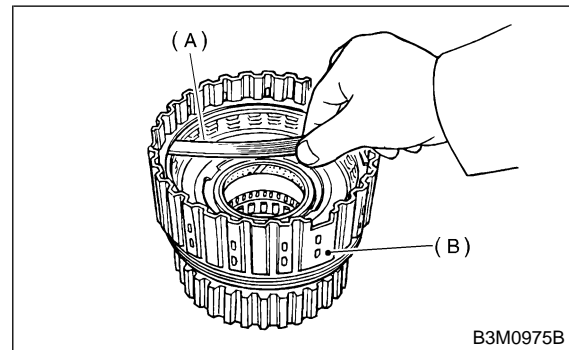

- (A) Thickness gauge
- (B) Low clutch drum

If the clearance is out of the specified range, select a proper retaining plate so that the standard clearance can be obtained.

Available retaining plates	
Part No.	Thickness mm (in)
31567AA830	3.8 (0.150)
31567AA840	4.0 (0.157)
31567AA850	4.2 (0.165)
31567AA860	4.4 (0.173)
31567AA870	4.6 (0.181)

### 24. 2-4 Brake S510205

#### A: REMOVAL S510205A18

- 1) Extract the torque converter clutch assembly. <Ref. to AT-35, REMOVAL, Torque Converter Clutch Assembly.>
- 2) Remove the input shaft.

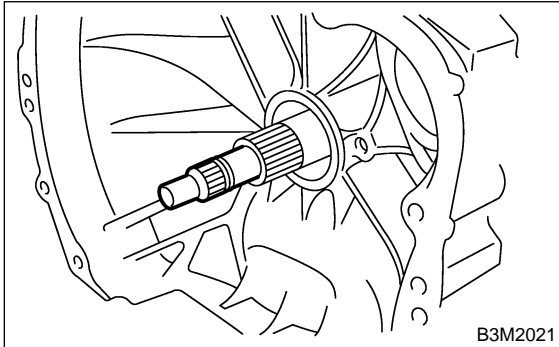

- 3) Disconnect the air breather hose. <Ref. to AT-28, REMOVAL, Air Breather Hose.>
- 4) Disconnect transmission harness connector from stay.

**NOTE:**

Lift-up lever behind the connector and disconnect it from stay.

- 5) Disconnect inhibitor switch connector from stay.
- 6) Remove the oil charger pipe. <Ref. to AT-29, REMOVAL, Oil Charger Pipe.>
- 7) Remove the oil cooler inlet and outlet pipes with washers. <Ref. to AT-30, REMOVAL, Oil Cooler Pipes.>
- 8) Remove rear vehicle speed sensor, and separate the transmission case and extension case. <Ref. to AT-36, REMOVAL, Extension Case.>
- 9) Remove reduction driven gear.  
WITHOUT VTD <Ref. to AT-48, WITHOUT VTD, REMOVAL, Reduction Driven Gear.>  
WITH VTD <Ref. to AT-48, WITH VTD, REMOVAL, Reduction Driven Gear.>
- 10) Separation of torque converter clutch case and transmission case. <Ref. to AT-58, REMOVAL, Torque Converter Clutch Case.>
- 11) Remove the oil pan and control valve body. <Ref. to AT-81, REMOVAL, Control Valve Body.>
- 12) Remove the oil pump housing. <Ref. to AT-62, REMOVAL, Oil Pump.>

- 13) Remove 2-4 brake seal.

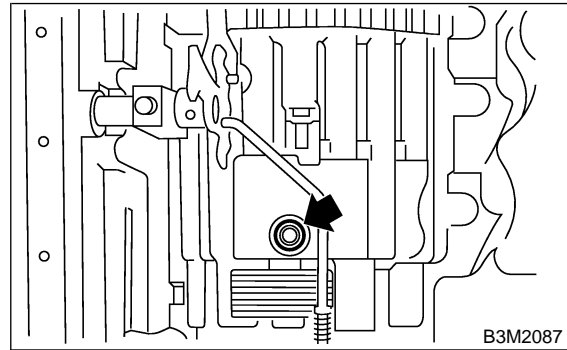

- 14) Take out the high clutch and reverse clutch assembly. <Ref. to AT-87, REMOVAL, High Clutch and Reverse Clutch.>
- 15) Take out the thrust needle bearing, planetary gear assembly and the low clutch assembly. <Ref. to AT-92, REMOVAL, Planetary Gear and Low Clutch.>
- 16) Remove snap ring.

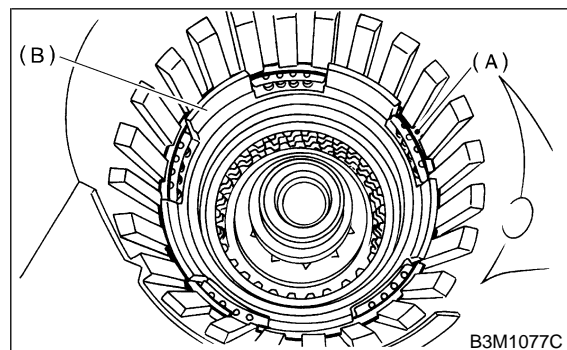

- (A) Snap ring
- (B) 2-4 brake piston

- 17) Take out 2-4 brake return spring.

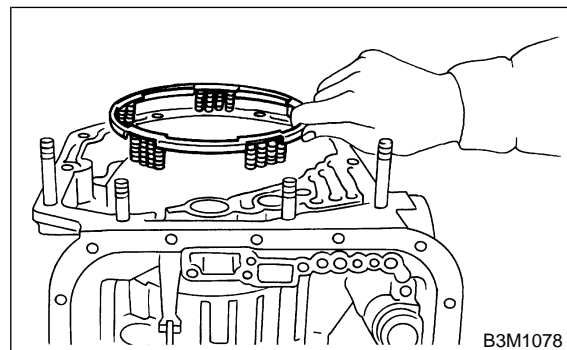

18) Take out 2-4 brake piston and piston retainer.

**CAUTION:**

When removing the brake piston 2-4 and piston retainer, be careful not to rub or bump them against the transmission case.

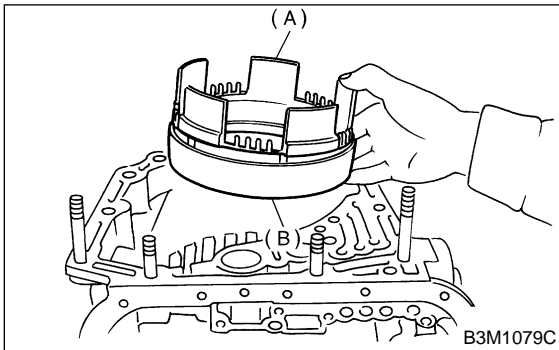

(A) 2-4 brake piston  
(B) 2-4 brake piston retainer

19) Separate 2-4 brake piston and piston retainer.

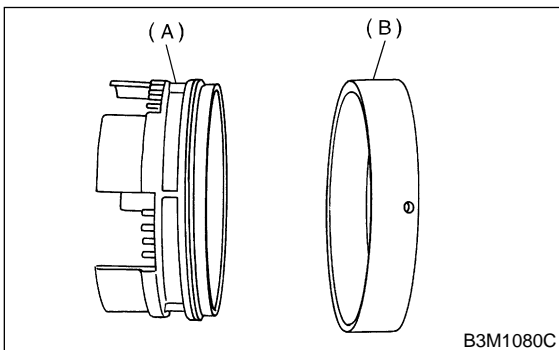

(A) 2-4 brake piston  
(B) 2-4 brake piston retainer

**B: INSTALLATION** S510205A11

1) Install 2-4 brake piston to 2-4 brake piston retainer.

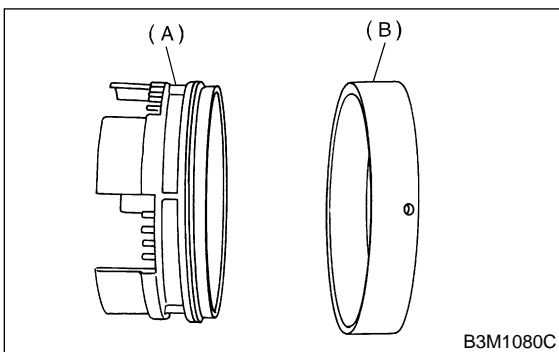

(A) 2-4 brake piston  
(B) 2-4 brake retainer

2) Install 2-4 brake piston and retainer to transmission case.

**CAUTION:**

Align the hole in the 2-4 brake seal of transmission case with the hole in 2-4 brake piston retainer during installation.

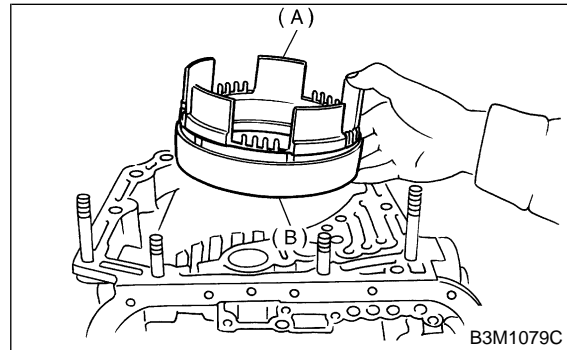

(A) 2-4 brake piston  
(B) 2-4 brake piston retainer

3) Install 2-4 brake piston return spring to transmission case.

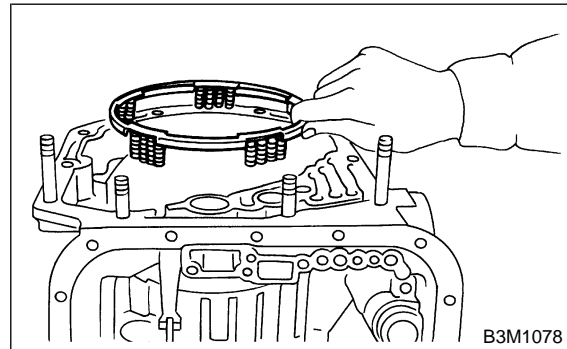

4) Position snap ring in transmission. Using ST, press the snap ring into place.  
ST 498677100 COMPRESSOR

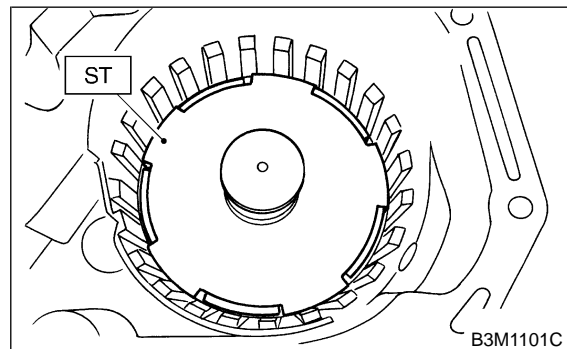

5) Install planetary gear and low clutch assembly to transmission case.

Install carefully while rotating the low clutch and planetary gear assembly slowly paying special attention not to damage the seal ring. <Ref. to AT-93, INSTALLATION, Planetary Gear and Low Clutch.>

## 2-4 BRAKE

### Automatic Transmission

6) Install pressure plate, drive plate, driven plate, retaining plate and snap ring.

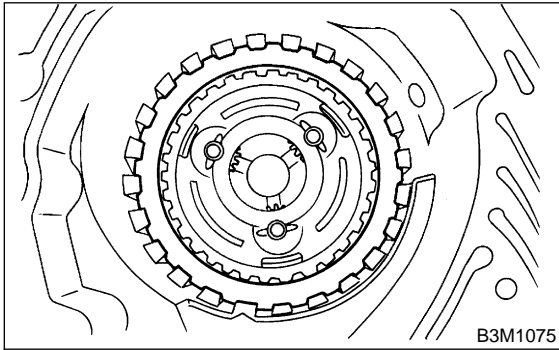

7) Install 2-4 brake oil seal to transmission case.

**NOTE:**

Be sure to use a new one.

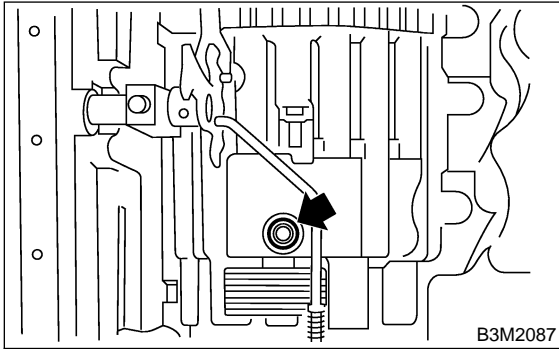

8) After all 2-4 brake component parts have been installed, blow in air intermittently and confirm the operation of the brake.

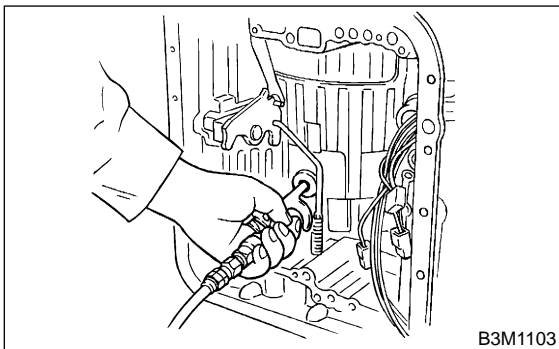

9) Check the clearance between the retaining plate and the snap ring. <Ref. to AT-103, INSPECTION, 2-4 Brake.>

10) Install leaf spring of 2-4 brake.

**NOTE:**

Be careful not to mistake the location of the leaf spring to be inserted.

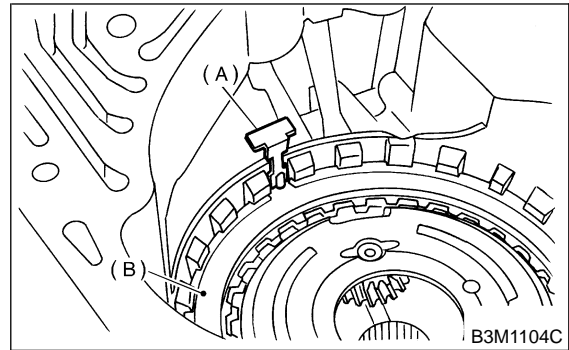

- (A) Leaf spring
- (B) Retaining plate

11) Install thrust needle bearing.

**NOTE:**

Install thrust needle bearing in the correct direction.

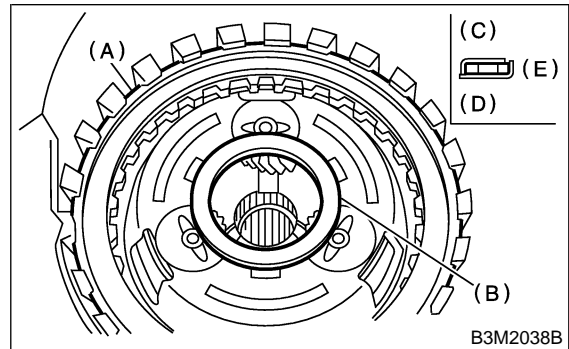

- (A) Snap ring
- (B) Thrust needle bearing
- (C) Up side
- (D) Down side
- (E) Outside

12) Install front sun gear and thrust needle bearing.

**NOTE:**

Install thrust needle bearing in the correct direction.

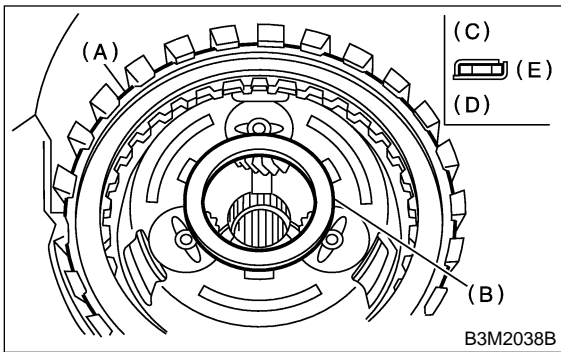

- (A) Front sun gear
- (B) Thrust needle bearing
- (C) Up side
- (D) Down side
- (E) Outside

13) Install the high clutch assembly. <Ref. to AT-88, INSTALLATION, High Clutch and Reverse Clutch.>

14) Install oil pump housing to transmission case. <Ref. to AT-63, INSTALLATION, Oil Pump.>

15) Install the control valve body and oil pan. <Ref. to AT-82, INSTALLATION, Control Valve Body.>

16) Install the torque converter clutch case assembly to the transmission case assembly. <Ref. to AT-59, INSTALLATION, Torque Converter Clutch Case.>

17) Insert inhibitor switch and transmission connector into stay.

18) Install air breather hose. <Ref. to AT-28, INSTALLATION, Air Breather Hose.>

19) Install the oil cooler pipes. <Ref. to AT-30, INSTALLATION, Oil Cooler Pipes.>

20) Install the oil charger pipe with O-ring. <Ref. to AT-29, INSTALLATION, Oil Charger Pipe.>

21) Insert the input shaft while turning lightly by hand.

**CAUTION:**

**Be careful not to damage the bushing.**

**Normal protrusion A:**

**50 — 55 mm (1.97 — 2.17 in)**

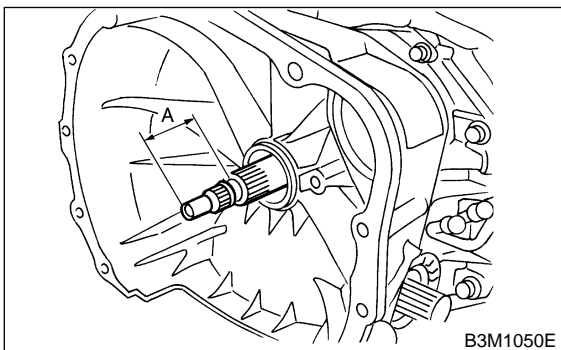

22) Install the torque converter clutch assembly. <Ref. to AT-35, INSTALLATION, Torque Converter Clutch Assembly.>

**C: INSPECTION** SS10205A10

- Drive plate facing for wear and damage
- Snap ring for wear and spring retainer for deformation
- Lip seal and lathe cut seal ring for damage
- Measure the total end play and adjust to within specifications. <Ref. to AT-66, ADJUSTMENT, Oil Pump.>

1) Inspect the clearance between the retaining plate and the snap ring.

**NOTE:**

Select a retaining plate with a suitable value from the following table, so that the clearance becomes the standard value.

**Standard value:**

**0.8 — 1.2 mm (0.031 — 0.047 in)**

**Allowable limit:**

**1.5 mm (0.059 in)**

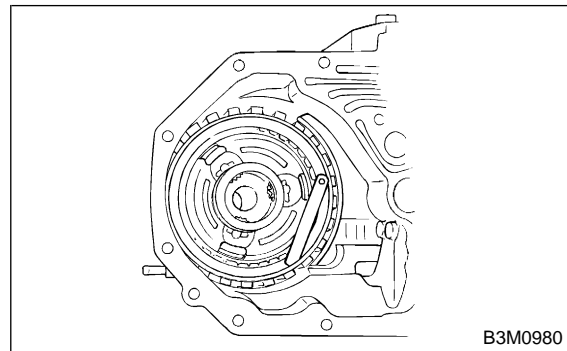

Available retaining plates	
Part No.	Thickness mm (in)
31567AA612	5.6 (0.220)
31567AA622	5.8 (0.228)
31567AA632	6.0 (0.236)
31567AA642	6.2 (0.244)
31567AA652	6.4 (0.252)
31567AA662	6.6 (0.260)



### 24. 2-4 Brake S510205

#### A: REMOVAL S510205A18

- 1) Extract the torque converter clutch assembly. <Ref. to AT-35, REMOVAL, Torque Converter Clutch Assembly.>
- 2) Remove the input shaft.

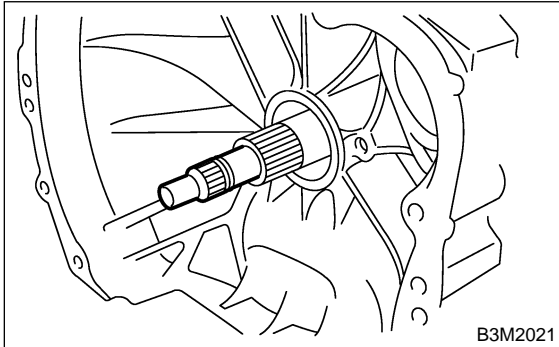

- 3) Disconnect the air breather hose. <Ref. to AT-28, REMOVAL, Air Breather Hose.>
- 4) Disconnect transmission harness connector from stay.

**NOTE:**

Lift-up lever behind the connector and disconnect it from stay.

- 5) Disconnect inhibitor switch connector from stay.
- 6) Remove the oil charger pipe. <Ref. to AT-29, REMOVAL, Oil Charger Pipe.>
- 7) Remove the oil cooler inlet and outlet pipes with washers. <Ref. to AT-30, REMOVAL, Oil Cooler Pipes.>
- 8) Remove rear vehicle speed sensor, and separate the transmission case and extension case. <Ref. to AT-36, REMOVAL, Extension Case.>
- 9) Remove reduction driven gear.  
WITHOUT VTD <Ref. to AT-48, WITHOUT VTD, REMOVAL, Reduction Driven Gear.>  
WITH VTD <Ref. to AT-48, WITH VTD, REMOVAL, Reduction Driven Gear.>
- 10) Separation of torque converter clutch case and transmission case. <Ref. to AT-58, REMOVAL, Torque Converter Clutch Case.>
- 11) Remove the oil pan and control valve body. <Ref. to AT-81, REMOVAL, Control Valve Body.>
- 12) Remove the oil pump housing. <Ref. to AT-62, REMOVAL, Oil Pump.>

- 13) Remove 2-4 brake seal.

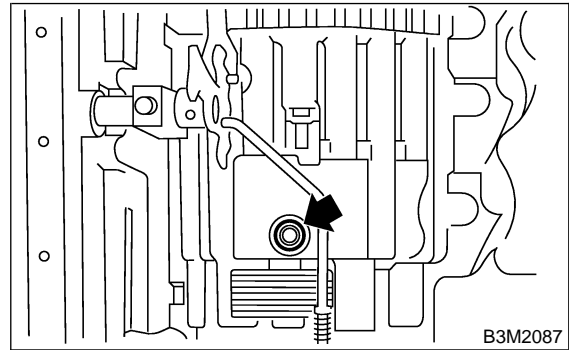

- 14) Take out the high clutch and reverse clutch assembly. <Ref. to AT-87, REMOVAL, High Clutch and Reverse Clutch.>
- 15) Take out the thrust needle bearing, planetary gear assembly and the low clutch assembly. <Ref. to AT-92, REMOVAL, Planetary Gear and Low Clutch.>
- 16) Remove snap ring.

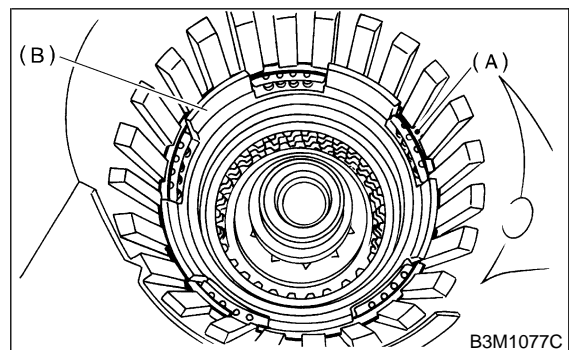

- (A) Snap ring
- (B) 2-4 brake piston

- 17) Take out 2-4 brake return spring.

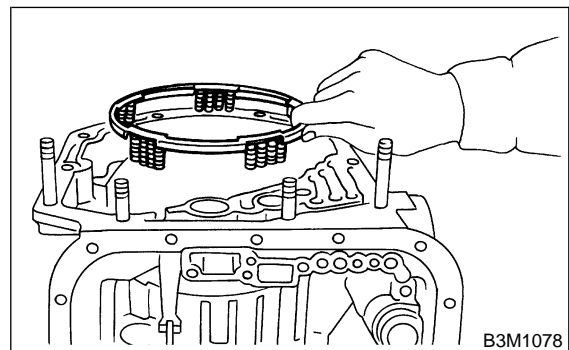

18) Take out 2-4 brake piston and piston retainer.

**CAUTION:**

When removing the brake piston 2-4 and piston retainer, be careful not to rub or bump them against the transmission case.

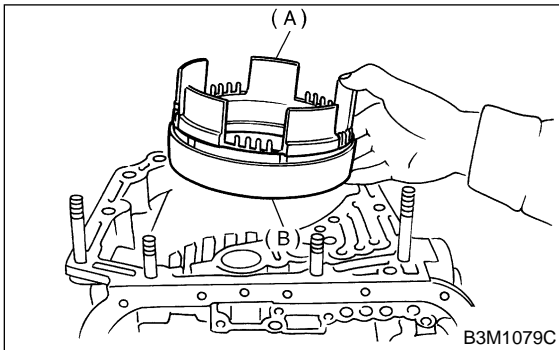

(A) 2-4 brake piston  
(B) 2-4 brake piston retainer

19) Separate 2-4 brake piston and piston retainer.

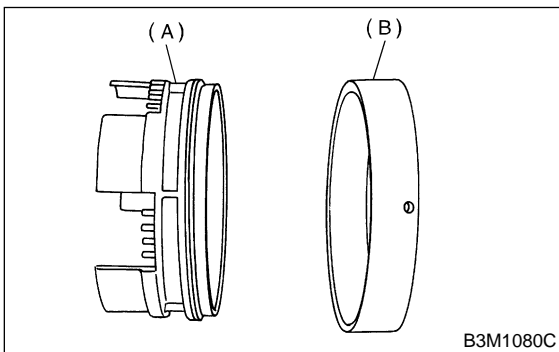

(A) 2-4 brake piston  
(B) 2-4 brake piston retainer

**B: INSTALLATION** S510205A11

1) Install 2-4 brake piston to 2-4 brake piston retainer.

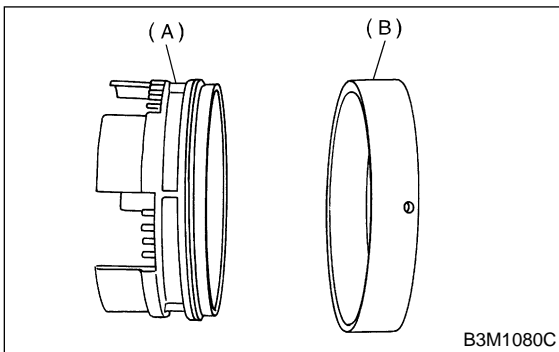

(A) 2-4 brake piston  
(B) 2-4 brake retainer

2) Install 2-4 brake piston and retainer to transmission case.

**CAUTION:**

Align the hole in the 2-4 brake seal of transmission case with the hole in 2-4 brake piston retainer during installation.

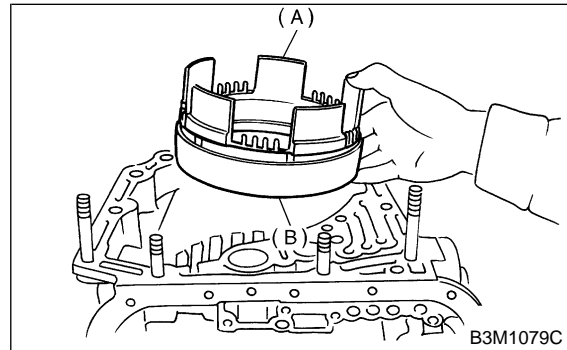

(A) 2-4 brake piston  
(B) 2-4 brake piston retainer

3) Install 2-4 brake piston return spring to transmission case.

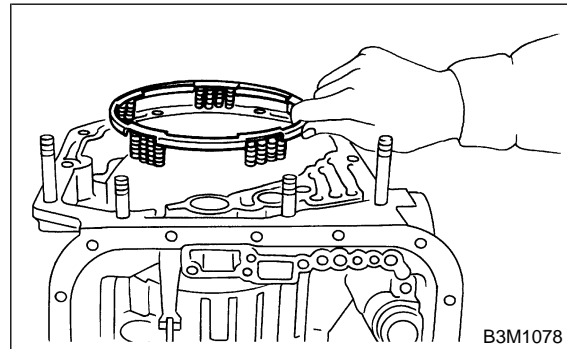

4) Position snap ring in transmission. Using ST, press the snap ring into place.  
ST 498677100 COMPRESSOR

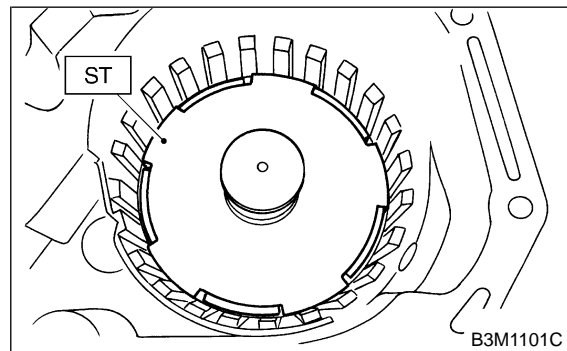

5) Install planetary gear and low clutch assembly to transmission case.

Install carefully while rotating the low clutch and planetary gear assembly slowly paying special attention not to damage the seal ring. <Ref. to AT-93, INSTALLATION, Planetary Gear and Low Clutch.>

## 2-4 BRAKE

### Automatic Transmission

6) Install pressure plate, drive plate, driven plate, retaining plate and snap ring.

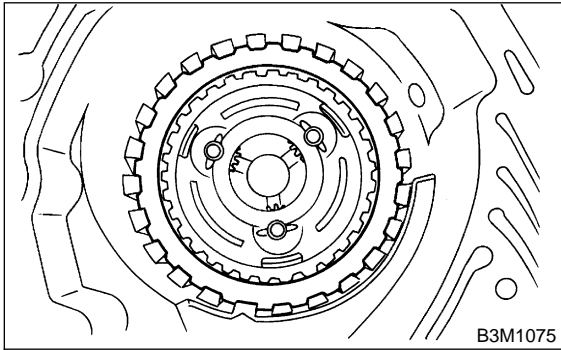

7) Install 2-4 brake oil seal to transmission case.

**NOTE:**

Be sure to use a new one.

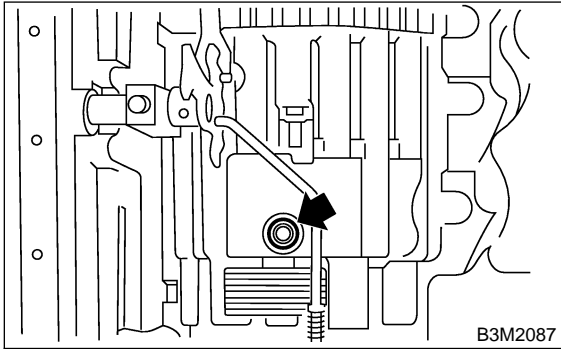

8) After all 2-4 brake component parts have been installed, blow in air intermittently and confirm the operation of the brake.

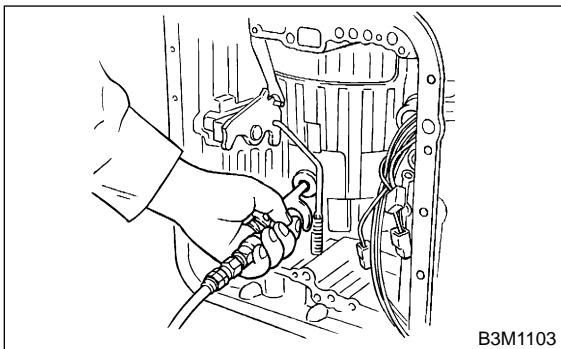

9) Check the clearance between the retaining plate and the snap ring. <Ref. to AT-103, INSPECTION, 2-4 Brake.>

10) Install leaf spring of 2-4 brake.

**NOTE:**

Be careful not to mistake the location of the leaf spring to be inserted.

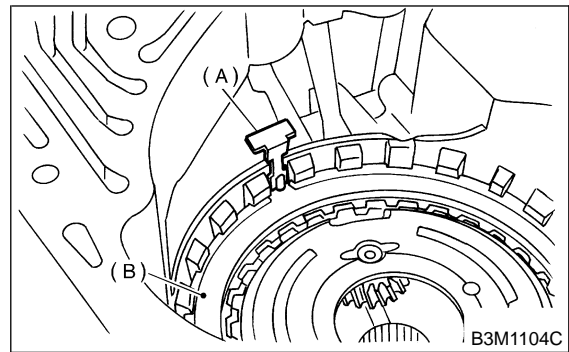

- (A) Leaf spring
- (B) Retaining plate

11) Install thrust needle bearing.

**NOTE:**

Install thrust needle bearing in the correct direction.

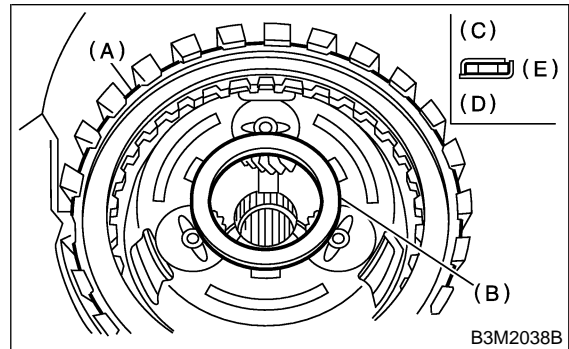

- (A) Snap ring
- (B) Thrust needle bearing
- (C) Up side
- (D) Down side
- (E) Outside

12) Install front sun gear and thrust needle bearing.

**NOTE:**

Install thrust needle bearing in the correct direction.

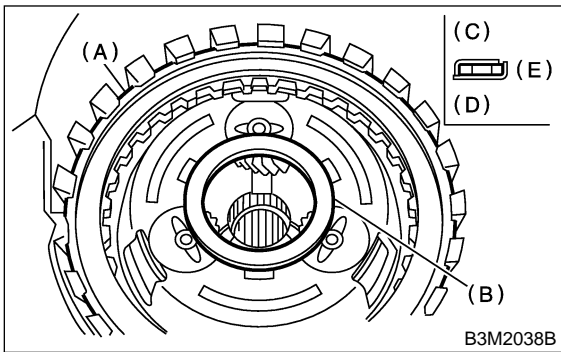

- (A) Front sun gear
- (B) Thrust needle bearing
- (C) Up side
- (D) Down side
- (E) Outside

13) Install the high clutch assembly. <Ref. to AT-88, INSTALLATION, High Clutch and Reverse Clutch.>

14) Install oil pump housing to transmission case. <Ref. to AT-63, INSTALLATION, Oil Pump.>

15) Install the control valve body and oil pan. <Ref. to AT-82, INSTALLATION, Control Valve Body.>

16) Install the torque converter clutch case assembly to the transmission case assembly. <Ref. to AT-59, INSTALLATION, Torque Converter Clutch Case.>

17) Insert inhibitor switch and transmission connector into stay.

18) Install air breather hose. <Ref. to AT-28, INSTALLATION, Air Breather Hose.>

19) Install the oil cooler pipes. <Ref. to AT-30, INSTALLATION, Oil Cooler Pipes.>

20) Install the oil charger pipe with O-ring. <Ref. to AT-29, INSTALLATION, Oil Charger Pipe.>

21) Insert the input shaft while turning lightly by hand.

**CAUTION:**

**Be careful not to damage the bushing.**

**Normal protrusion A:**

**50 — 55 mm (1.97 — 2.17 in)**

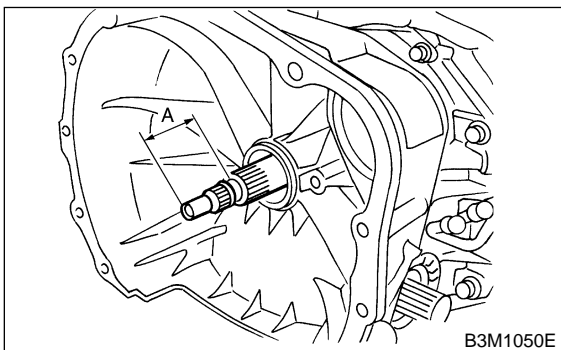

22) Install the torque converter clutch assembly. <Ref. to AT-35, INSTALLATION, Torque Converter Clutch Assembly.>

**C: INSPECTION** SS10205A10

- Drive plate facing for wear and damage
- Snap ring for wear and spring retainer for deformation
- Lip seal and lathe cut seal ring for damage
- Measure the total end play and adjust to within specifications. <Ref. to AT-66, ADJUSTMENT, Oil Pump.>

1) Inspect the clearance between the retaining plate and the snap ring.

**NOTE:**

Select a retaining plate with a suitable value from the following table, so that the clearance becomes the standard value.

**Standard value:**

**0.8 — 1.2 mm (0.031 — 0.047 in)**

**Allowable limit:**

**1.5 mm (0.059 in)**

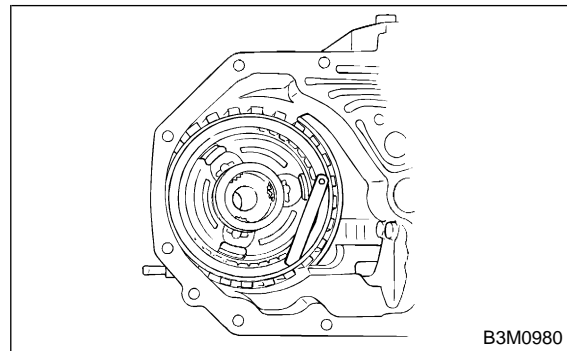

Available retaining plates	
Part No.	Thickness mm (in)
31567AA612	5.6 (0.220)
31567AA622	5.8 (0.228)
31567AA632	6.0 (0.236)
31567AA642	6.2 (0.244)
31567AA652	6.4 (0.252)
31567AA662	6.6 (0.260)

## 25. One-way Clutch SS10215

### A: REMOVAL SS10215A18

- 1) Extract the torque converter clutch assembly. <Ref. to AT-35, REMOVAL, Torque Converter Clutch Assembly.>
- 2) Remove the input shaft.

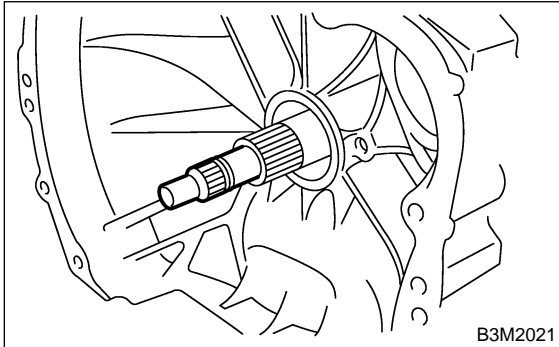

- 3) Disconnect the air breather hose. <Ref. to AT-28, REMOVAL, Air Breather Hose.>
- 4) Disconnect transmission harness connector from stay.

**NOTE:**

Lift-up lever behind the connector and disconnect it from stay.

- 5) Disconnect inhibitor switch connector from stay.
- 6) Remove the oil charger pipe. <Ref. to AT-29, REMOVAL, Oil Charger Pipe.>
- 7) Remove the oil cooler inlet and outlet pipes. <Ref. to AT-30, REMOVAL, Oil Cooler Pipes.>
- 8) Separation of torque converter clutch case and transmission case. <Ref. to AT-58, REMOVAL, Torque Converter Clutch Case.>
- 9) Separate transmission case and extension case sections. <Ref. to AT-36, REMOVAL, Extension Case.>
- 10) Remove the reduction driven gear. WITHOUT VTD <Ref. to AT-48, WITHOUT VTD, REMOVAL, Reduction Driven Gear.> WITH VTD <Ref. to AT-48, WITH VTD, REMOVAL, Reduction Driven Gear.>
- 11) Remove the reduction drive gear. <Ref. to AT-48, REMOVAL, Reduction Drive Gear.>
- 12) Remove control valve assembly. <Ref. to AT-81, REMOVAL, Control Valve Body Assembly.>
- 13) Remove the oil pump housing. <Ref. to AT-62, REMOVAL, Oil Pump.>
- 14) Take out the high clutch and reverse clutch assembly. <Ref. to AT-87, REMOVAL, High Clutch and Reverse Clutch.>
- 15) Take out the thrust needle bearing, planetary gear assembly. <Ref. to AT-92, REMOVAL, Planetary Gear and Low Clutch.>

- 16) Take out 2-4 brake return spring, piston and piston retainer. <Ref. to AT-100, REMOVAL, 2-4 Brake.>
- 17) Pull out leaf spring.

**NOTE:**

Be careful not to bend leaf spring during removal.

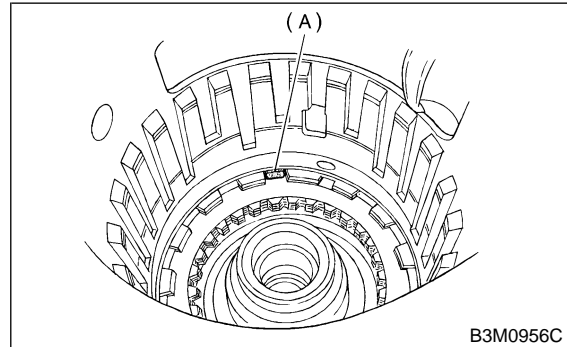

(A) Leaf spring

- 18) Remove snap ring.

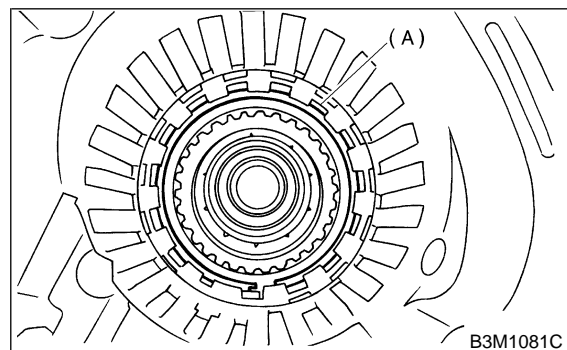

(A) Snap ring

- 19) Take out retaining plate, drive plate, driven plate and dish plate.

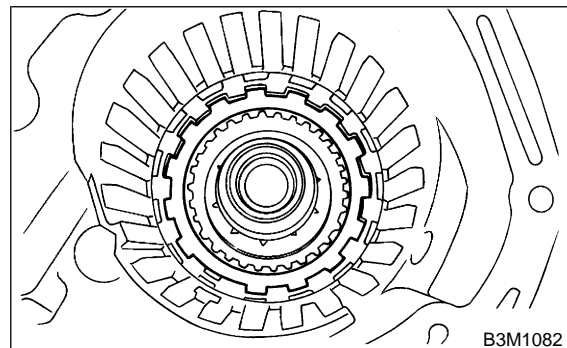

20) Turn the transmission case upside down, and then take out the socket bolts while holding the one-way clutch inner race with hand.

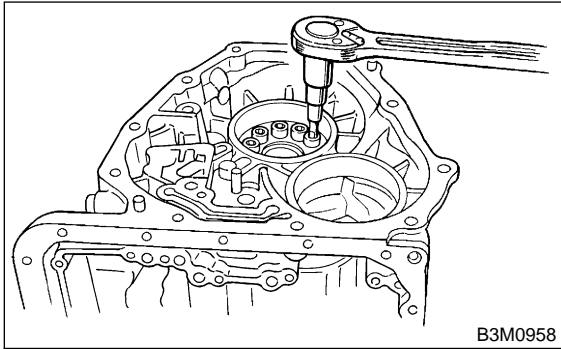

## B: INSTALLATION

S510215A11

- 1) Install the one-way clutch inner race, spring retainer and return spring.
- 2) Tighten socket head bolts from the rear side of the transmission case.

### Tightening torque:

**25 N·m (2.5 kgf-m, 18.1 ft-lb)**

### NOTE:

Be sure to tighten evenly.

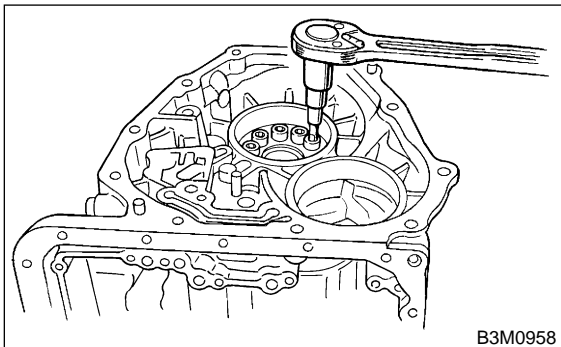

- 3) Install thrust needle bearing.

### NOTE:

Place transmission case with the front facing up.

- 4) Installation of the low & reverse brake: Install dish plate, driven plates, drive plates, and a retaining plate, and secure with a snap ring.

### NOTE:

Pay attention to the orientation of the dish plate.

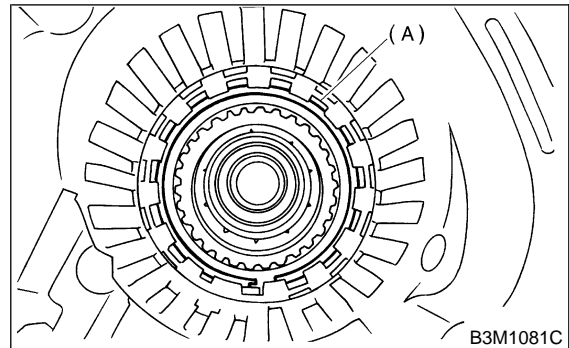

(A) Snap ring

- 5) Apply compressed air intermittently to check for operation.

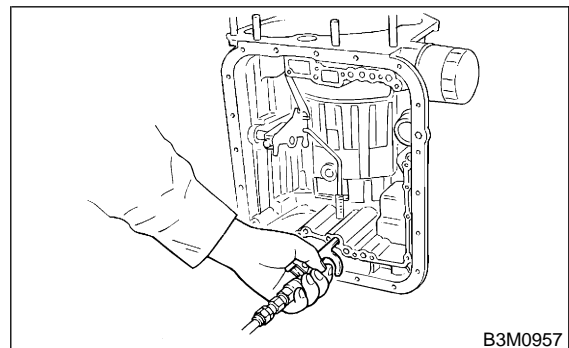

- 6) Check the clearance and select retaining plate. <Ref. to AT-110, INSPECTION, Low and Reverse Brake.>
- 7) Install 2-4 brake. <Ref. to AT-101, INSTALLATION, 2-4 Brake.>
- 8) Install planetary gear and low clutch assembly to transmission case. Install carefully while rotating the low clutch and planetary gear assembly slowly paying special attention not to damage the seal ring. <Ref. to AT-93, INSTALLATION, Planetary Gear & Low Clutch.>
- 9) Install the high clutch assembly. <Ref. to AT-88, INSTALLATION, High Clutch and Reverse Clutch.>
- 10) Install the oil pump housing assembly. <Ref. to AT-63, INSTALLATION, Oil Pump.>
- 11) Install control valve assembly and oil pan. <Ref. to AT-82, INSTALLATION, Control Valve Body Assembly.>
- 12) Install the torque converter clutch case assembly. <Ref. to AT-59, INSTALLATION, Torque Converter Clutch Case.>
- 13) Install reduction drive gear.

# ONE-WAY CLUTCH

Automatic Transmission

- 14) Install reduction driven gear.  
WITHOUT VTD <Ref. to AT-48, WITHOUT VTD, INSTALLATION, Reduction Driven Gear.>  
WITH VTD <Ref. to AT-49, WITH VTD, INSTALLATION, Reduction Driven Gear.>
- 15) Install the extension case to the transmission case. <Ref. to AT-36, INSTALLATION, Extension Case.>
- 16) Install the rear vehicle speed sensor.

## Tightening torque:

**7 N·m (0.7 kgf-m, 5.1 ft-lb)**

- 17) Insert inhibitor switch and transmission connector into stay.

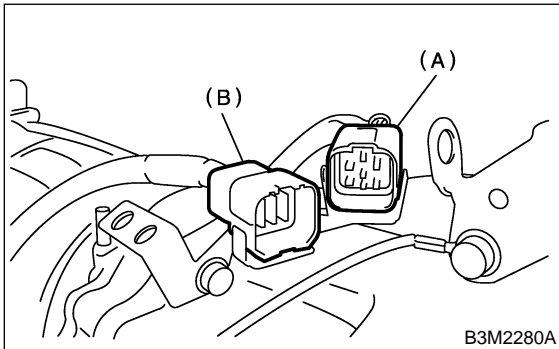

- (A) Transmission harness
- (B) Inhibitor switch harness

- 18) Install air breather hose. <Ref. to AT-28, INSTALLATION, Air Breather Hose.>
- 19) Install the oil cooler pipes. <Ref. to AT-30, INSTALLATION, Oil Cooler Pipes.>
- 20) Install the oil charger pipe with O-ring. <Ref. to AT-29, INSTALLATION, Oil Charger Pipe.>
- 21) Insert the input shaft while turning lightly by hand.

## CAUTION:

**Be careful not to damage the bushing.**

## Normal protrusion A:

**50 — 55 mm (1.97 — 2.17 in)**

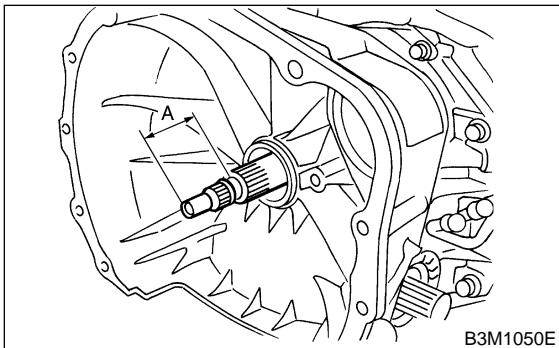

- 22) Install the torque converter clutch assembly. <Ref. to AT-35, INSTALLATION, Torque Converter Clutch Assembly.>

## C: DISASSEMBLY S510215A06

### 1. ONE-WAY CLUTCH INNER RACE S510215A0601

- 1) Remove seal rings.

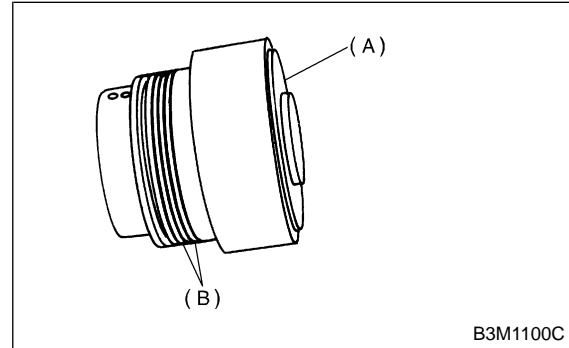

- (A) One way clutch inner race
- (B) Seal rings

- 2) Using ST, remove needle bearing.  
ST 398527700 PULLER ASSY

### 2. ONE-WAY CLUTCH OUTER RACE

S510215A0602

- 1) Remove the one-way clutch after taking out the snap ring.

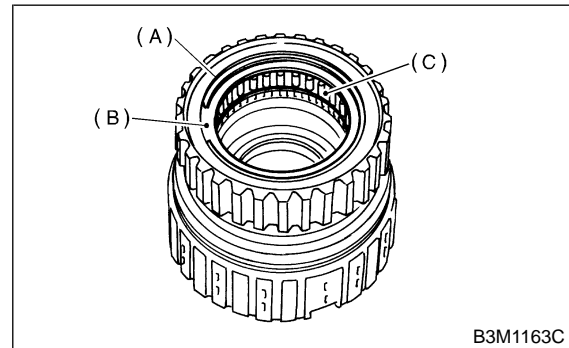

- (A) Snap ring
- (B) Plate
- (C) One-way clutch

- 2) Remove the needle bearing after taking out the snap ring.

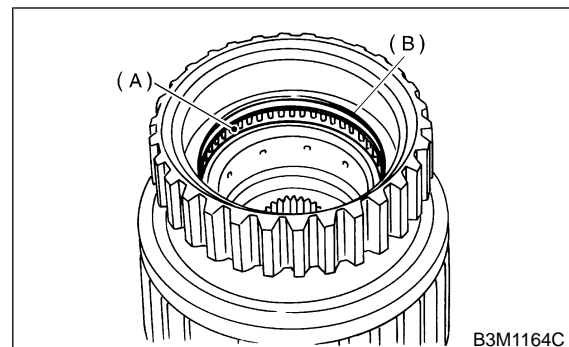

- (A) Needle bearing
- (B) Snap ring

## D: ASSEMBLY SS10215A02

### 1. ONE-WAY CLUTCH INNER RACE SS10215A0201

1) Using a press and ST, install the needle bearing to the inner race.

ST 398497701 INSTALLER

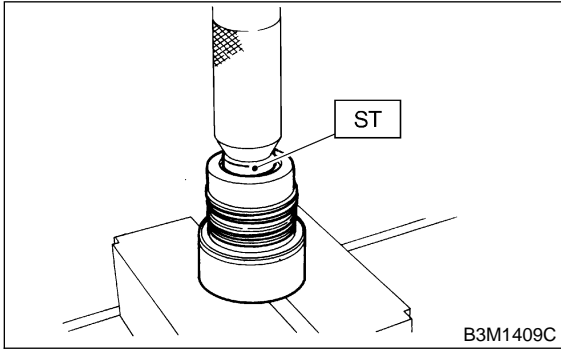

2) Install two seal rings to one-way clutch inner race.

**NOTE:**

Apply vaseline to the groove of the inner race and to the seal ring after installation, so that the seal ring will not expand.

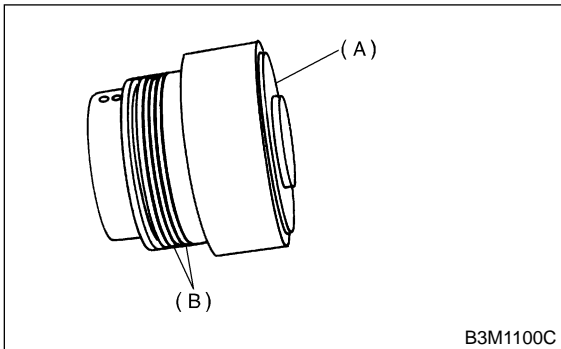

(A) One-way clutch inner race

(B) Seal rings

### 2. ONE-WAY CLUTCH OUTER RACE SS10215A0202

1) Install the needle bearing, and secure with the snap ring.

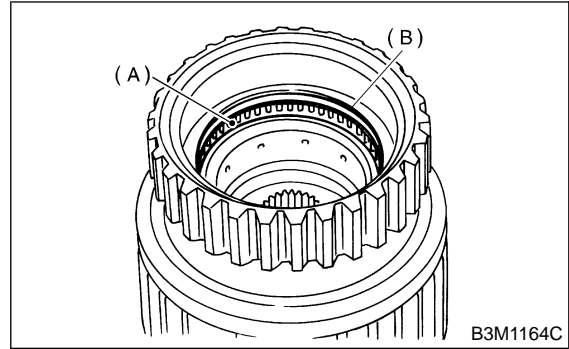

(A) Needle bearing

(B) Snap ring

2) Install the one-way clutch, one-way clutch inner race and plate, and secure with the snap ring.

**NOTE:**

Set the inner race. Make sure that the forward clutch is free in the clockwise direction and locked in the counterclockwise direction, as viewed from the front of the vehicle.

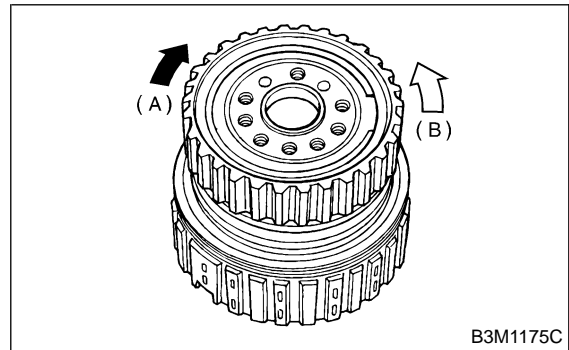

(A) Locked

(B) Free

## E: INSPECTION SS10215A10

- Make sure the snap ring is not worn and the seal rings are not damaged.
- Measure the total end play and adjust to within specifications. <Ref. to AT-66, ADJUSTMENT, Oil Pump.>



## 25. One-way Clutch SS10215

### A: REMOVAL SS10215A18

- 1) Extract the torque converter clutch assembly. <Ref. to AT-35, REMOVAL, Torque Converter Clutch Assembly.>
- 2) Remove the input shaft.

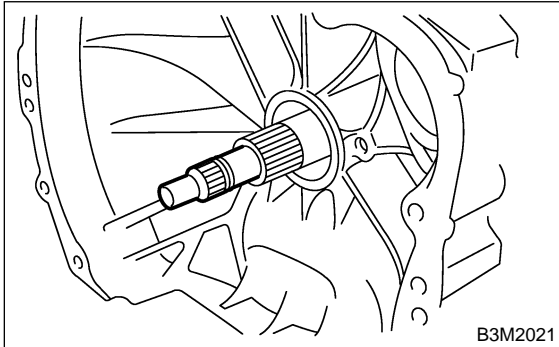

- 3) Disconnect the air breather hose. <Ref. to AT-28, REMOVAL, Air Breather Hose.>
- 4) Disconnect transmission harness connector from stay.

**NOTE:**

Lift-up lever behind the connector and disconnect it from stay.

- 5) Disconnect inhibitor switch connector from stay.
- 6) Remove the oil charger pipe. <Ref. to AT-29, REMOVAL, Oil Charger Pipe.>
- 7) Remove the oil cooler inlet and outlet pipes. <Ref. to AT-30, REMOVAL, Oil Cooler Pipes.>
- 8) Separation of torque converter clutch case and transmission case. <Ref. to AT-58, REMOVAL, Torque Converter Clutch Case.>
- 9) Separate transmission case and extension case sections. <Ref. to AT-36, REMOVAL, Extension Case.>
- 10) Remove the reduction driven gear. WITHOUT VTD <Ref. to AT-48, WITHOUT VTD, REMOVAL, Reduction Driven Gear.> WITH VTD <Ref. to AT-48, WITH VTD, REMOVAL, Reduction Driven Gear.>
- 11) Remove the reduction drive gear. <Ref. to AT-48, REMOVAL, Reduction Drive Gear.>
- 12) Remove control valve assembly. <Ref. to AT-81, REMOVAL, Control Valve Body Assembly.>
- 13) Remove the oil pump housing. <Ref. to AT-62, REMOVAL, Oil Pump.>
- 14) Take out the high clutch and reverse clutch assembly. <Ref. to AT-87, REMOVAL, High Clutch and Reverse Clutch.>
- 15) Take out the thrust needle bearing, planetary gear assembly. <Ref. to AT-92, REMOVAL, Planetary Gear and Low Clutch.>

- 16) Take out 2-4 brake return spring, piston and piston retainer. <Ref. to AT-100, REMOVAL, 2-4 Brake.>
- 17) Pull out leaf spring.

**NOTE:**

Be careful not to bend leaf spring during removal.

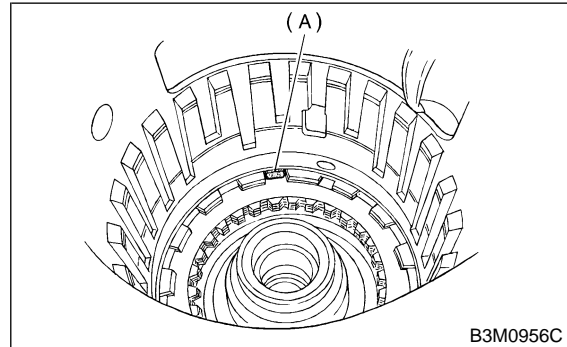

(A) Leaf spring

- 18) Remove snap ring.

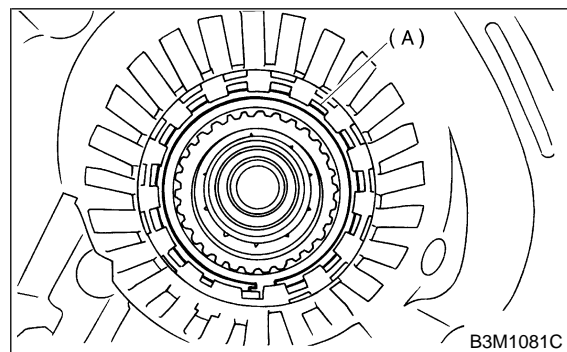

(A) Snap ring

- 19) Take out retaining plate, drive plate, driven plate and dish plate.

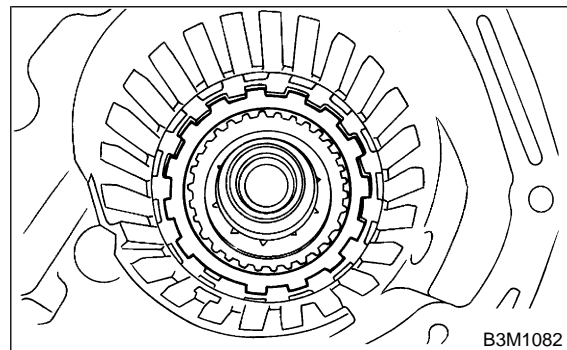

20) Turn the transmission case upside down, and then take out the socket bolts while holding the one-way clutch inner race with hand.

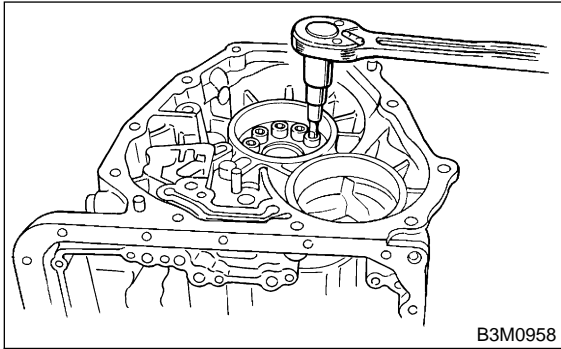

## B: INSTALLATION

S510215A11

- 1) Install the one-way clutch inner race, spring retainer and return spring.
- 2) Tighten socket head bolts from the rear side of the transmission case.

### Tightening torque:

**25 N·m (2.5 kgf-m, 18.1 ft-lb)**

### NOTE:

Be sure to tighten evenly.

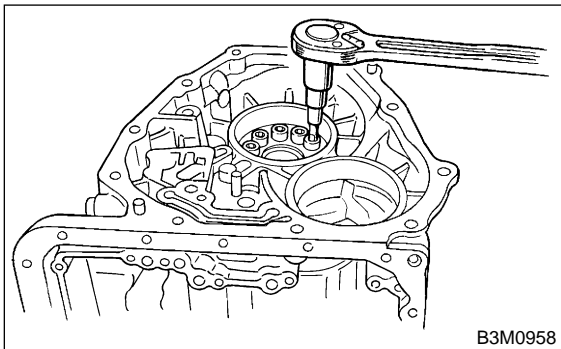

- 3) Install thrust needle bearing.

### NOTE:

Place transmission case with the front facing up.

- 4) Installation of the low & reverse brake: Install dish plate, driven plates, drive plates, and a retaining plate, and secure with a snap ring.

### NOTE:

Pay attention to the orientation of the dish plate.

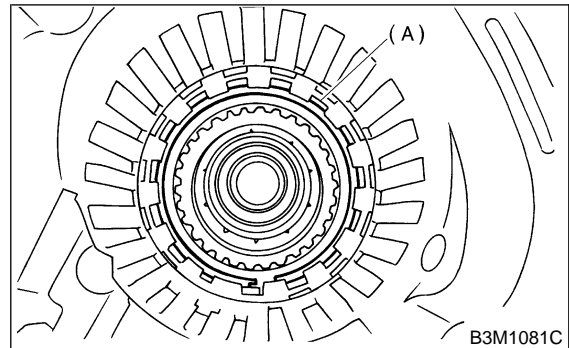

(A) Snap ring

- 5) Apply compressed air intermittently to check for operation.

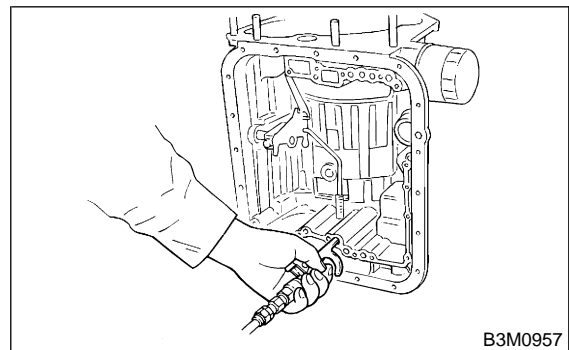

- 6) Check the clearance and select retaining plate. <Ref. to AT-110, INSPECTION, Low and Reverse Brake.>
- 7) Install 2-4 brake. <Ref. to AT-101, INSTALLATION, 2-4 Brake.>
- 8) Install planetary gear and low clutch assembly to transmission case. Install carefully while rotating the low clutch and planetary gear assembly slowly paying special attention not to damage the seal ring. <Ref. to AT-93, INSTALLATION, Planetary Gear & Low Clutch.>
- 9) Install the high clutch assembly. <Ref. to AT-88, INSTALLATION, High Clutch and Reverse Clutch.>
- 10) Install the oil pump housing assembly. <Ref. to AT-63, INSTALLATION, Oil Pump.>
- 11) Install control valve assembly and oil pan. <Ref. to AT-82, INSTALLATION, Control Valve Body Assembly.>
- 12) Install the torque converter clutch case assembly. <Ref. to AT-59, INSTALLATION, Torque Converter Clutch Case.>
- 13) Install reduction drive gear.

# ONE-WAY CLUTCH

Automatic Transmission

- 14) Install reduction driven gear.  
WITHOUT VTD <Ref. to AT-48, WITHOUT VTD, INSTALLATION, Reduction Driven Gear.>  
WITH VTD <Ref. to AT-49, WITH VTD, INSTALLATION, Reduction Driven Gear.>
- 15) Install the extension case to the transmission case. <Ref. to AT-36, INSTALLATION, Extension Case.>
- 16) Install the rear vehicle speed sensor.

## Tightening torque:

**7 N·m (0.7 kgf-m, 5.1 ft-lb)**

- 17) Insert inhibitor switch and transmission connector into stay.

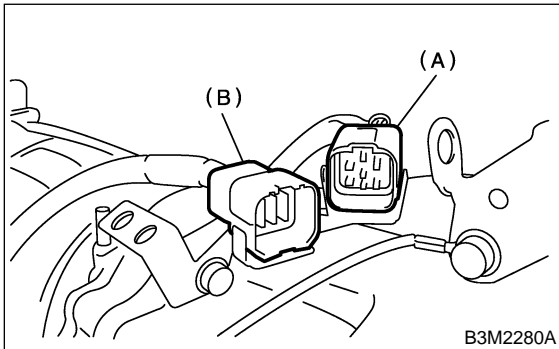

- (A) Transmission harness
- (B) Inhibitor switch harness

- 18) Install air breather hose. <Ref. to AT-28, INSTALLATION, Air Breather Hose.>
- 19) Install the oil cooler pipes. <Ref. to AT-30, INSTALLATION, Oil Cooler Pipes.>
- 20) Install the oil charger pipe with O-ring. <Ref. to AT-29, INSTALLATION, Oil Charger Pipe.>
- 21) Insert the input shaft while turning lightly by hand.

## CAUTION:

**Be careful not to damage the bushing.**

## Normal protrusion A:

**50 — 55 mm (1.97 — 2.17 in)**

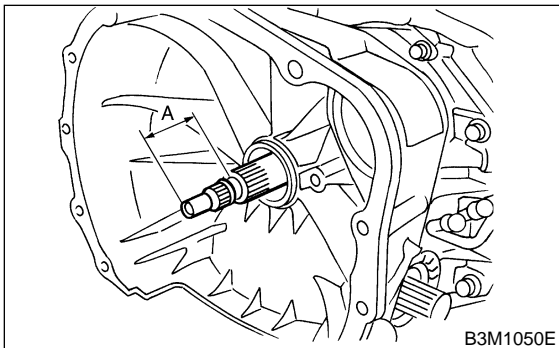

- 22) Install the torque converter clutch assembly. <Ref. to AT-35, INSTALLATION, Torque Converter Clutch Assembly.>

## C: DISASSEMBLY S510215A06

### 1. ONE-WAY CLUTCH INNER RACE S510215A0601

- 1) Remove seal rings.

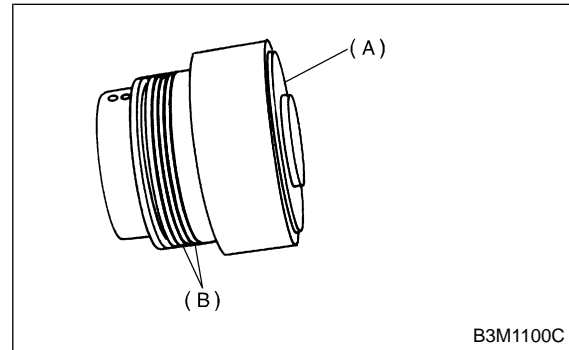

- (A) One way clutch inner race
- (B) Seal rings

- 2) Using ST, remove needle bearing.  
ST 398527700 PULLER ASSY

### 2. ONE-WAY CLUTCH OUTER RACE

S510215A0602

- 1) Remove the one-way clutch after taking out the snap ring.

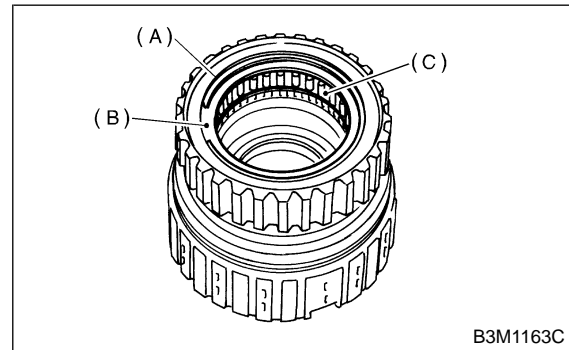

- (A) Snap ring
- (B) Plate
- (C) One-way clutch

- 2) Remove the needle bearing after taking out the snap ring.

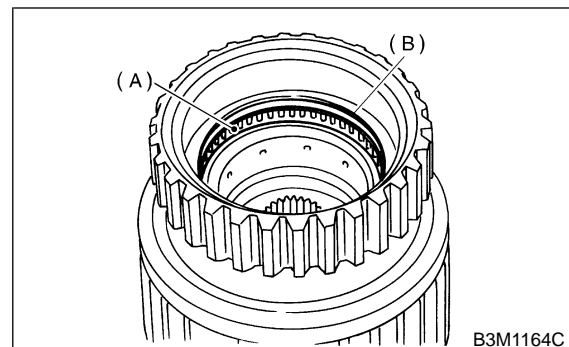

- (A) Needle bearing
- (B) Snap ring

## D: ASSEMBLY SS10215A02

### 1. ONE-WAY CLUTCH INNER RACE SS10215A0201

1) Using a press and ST, install the needle bearing to the inner race.

ST 398497701 INSTALLER

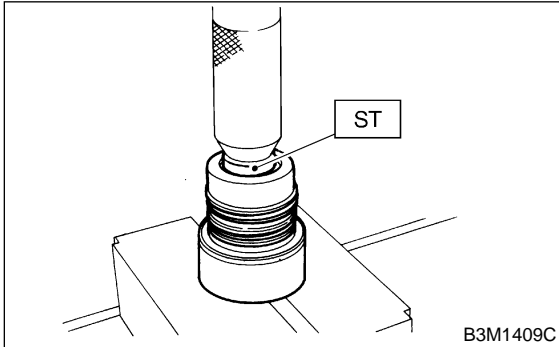

2) Install two seal rings to one-way clutch inner race.

**NOTE:**

Apply vaseline to the groove of the inner race and to the seal ring after installation, so that the seal ring will not expand.

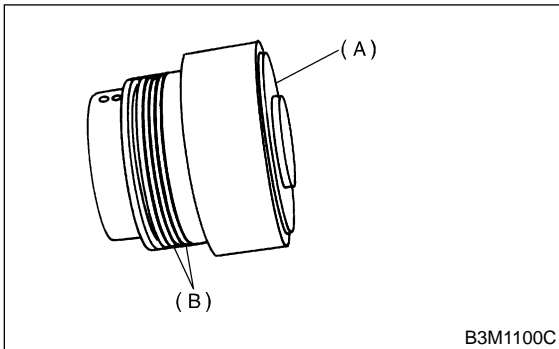

- (A) One-way clutch inner race
- (B) Seal rings

### 2. ONE-WAY CLUTCH OUTER RACE SS10215A0202

1) Install the needle bearing, and secure with the snap ring.

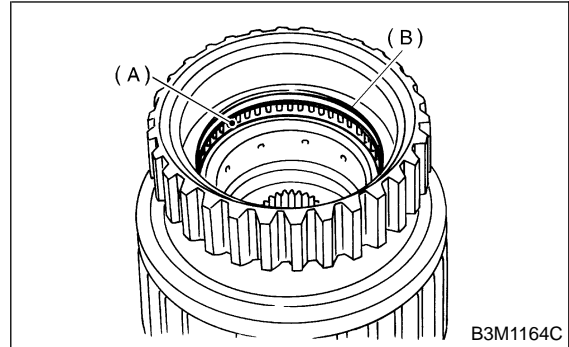

- (A) Needle bearing
- (B) Snap ring

2) Install the one-way clutch, one-way clutch inner race and plate, and secure with the snap ring.

**NOTE:**

Set the inner race. Make sure that the forward clutch is free in the clockwise direction and locked in the counterclockwise direction, as viewed from the front of the vehicle.

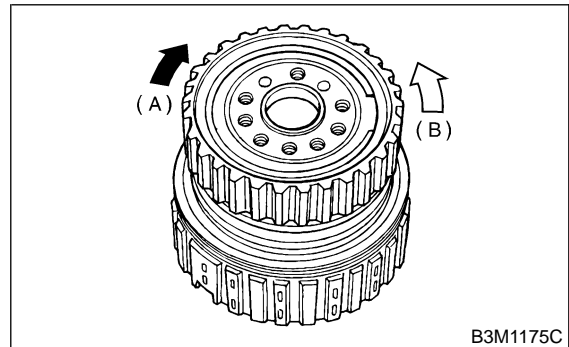

- (A) Locked
- (B) Free

## E: INSPECTION SS10215A10

- Make sure the snap ring is not worn and the seal rings are not damaged.
- Measure the total end play and adjust to within specifications. <Ref. to AT-66, ADJUSTMENT, Oil Pump.>

## 26. Low and Reverse Brake S510594

### A: REMOVAL S510594A18

- 1) Extract the torque converter clutch assembly. <Ref. to AT-35, REMOVAL, Torque Converter Clutch Assembly.>
- 2) Remove the input shaft.
- 3) Disconnect the air breather hose. <Ref. to AT-28, REMOVAL, Air Breather Hose.>
- 4) Disconnect transmission harness connector from stay.

**NOTE:**

Lift-up lever behind the connector and disconnect it from stay.

- 5) Disconnect inhibitor switch connector from stay.
- 6) Remove the oil charger pipe. <Ref. to AT-29, REMOVAL, Oil Charger Pipe.>
- 7) Remove the oil cooler inlet and outlet pipes. <Ref. to AT-30, REMOVAL, Oil Cooler Pipes.>
- 8) Separation of torque converter clutch case and transmission case. <Ref. to AT-58, REMOVAL, Torque Converter Clutch Case.>
- 9) Separate transmission case and extension case sections. <Ref. to AT-36, REMOVAL, Extension Case.>
- 10) Remove the reduction driven gear. WITHOUT VTD <Ref. to AT-48, WITHOUT VTD, REMOVAL, Reduction Driven Gear.> WITH VTD <Ref. to AT-48, WITH VTD, REMOVAL, Reduction Driven Gear.>
- 11) Remove the reduction drive gear. <Ref. to AT-51, REMOVAL, Reduction Drive Gear.>
- 12) Remove the oil pump housing. <Ref. to AT-62, REMOVAL, Oil Pump.>
- 13) Remove control valve assembly. <Ref. to AT-81, REMOVAL, Control Valve Body Assembly.>
- 14) Take out the high clutch and reverse clutch assembly. <Ref. to AT-87, REMOVAL, High Clutch and Reverse Clutch.>
- 15) Take out the thrust needle bearing, planetary gear assembly. <Ref. to AT-92, REMOVAL, Planetary Gear and Low Clutch.>
- 16) Take out 2-4 brake return spring, piston and piston retainer. <Ref. to AT-100, REMOVAL, 2-4 Brake.>
- 17) Remove one-way clutch inner race. <Ref. to AT-104, REMOVAL, One-way Clutch.>

- 18) Take out the low & reverse piston by applying compressed air.

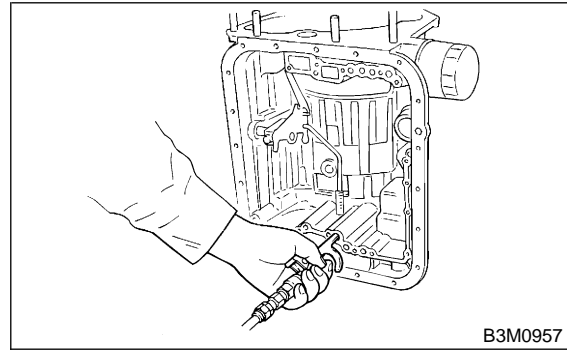

- 19) Take out the spring retainer, return spring and low & reverse piston.

### B: INSTALLATION S510594A11

- 1) Install the low and reverse piston.

**CAUTION:**

- Be careful not to tilt the piston when installing.
- Be careful not to damage the lip seal.

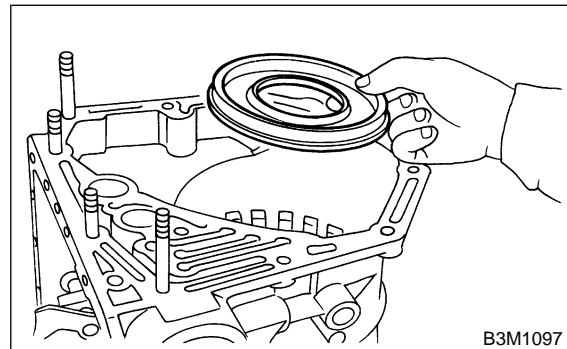

- 2) Install return spring.

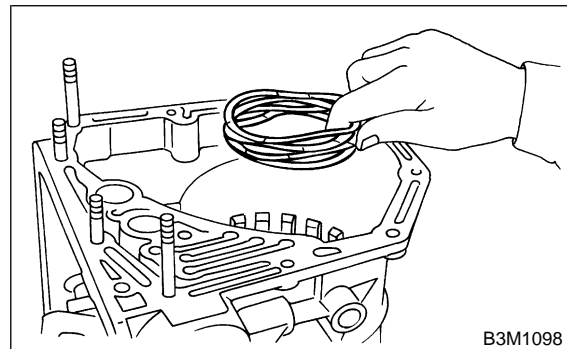

3) Install spring retainer.

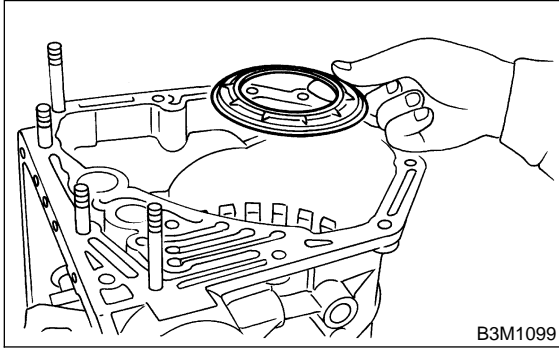

4) Install the one-way clutch inner race. <Ref. to AT-105, INSTALLATION, One-way Clutch.>

5) Install thrust needle bearing.

**NOTE:**

Place transmission case with the front facing up.

6) Installation of the low & reverse brake:  
Install dish plate, driven plates, drive plates, and a retaining plate, and secure with a snap ring.

**NOTE:**

Pay attention to the orientation of the dish plate.

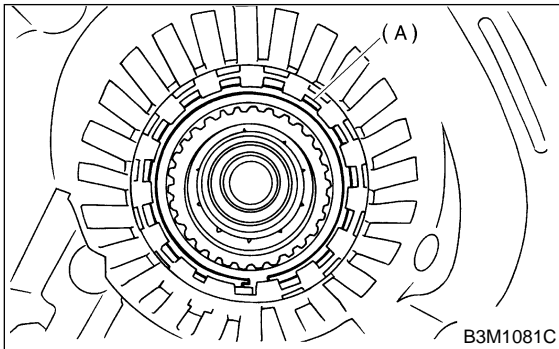

(A) Snap ring

7) Apply compressed air intermittently to check for operation.

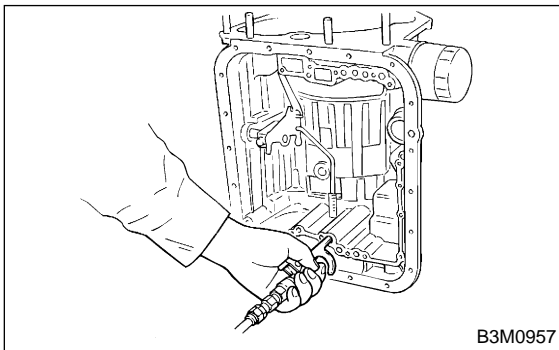

8) Check the clearance and select retaining plate. <Ref. to AT-110, INSPECTION, Low and Reverse Brake.>

9) Install 2-4 brake piston, retainer and return spring to transmission case. <Ref. to AT-101, INSTALLATION, 2-4 Brake.>

10) Install planetary gear and low clutch assembly to transmission case.

Install carefully while rotating the low clutch and planetary gear assembly slowly paying special attention not to damage the seal ring. <Ref. to AT-93, INSTALLATION, Planetary Gear and Low Clutch.>

11) Install the high clutch assembly. <Ref. to AT-88, INSTALLATION, High Clutch and Reverse Clutch.>

12) Install the oil pump housing assembly. <Ref. to AT-63, INSTALLATION, Oil Pump.>

13) Install the torque converter clutch case assembly to the transmission case assembly. <Ref. to AT-59, INSTALLATION, Torque Converter Clutch Case.>

14) Install reduction drive gear. <Ref. to AT-48, INSTALLATION, Reduction Drive Gear.>

15) Install reduction driven gear. WITHOUT VTD <Ref. to AT-48, WITHOUT VTD, INSTALLATION, Reduction Driven Gear.>

WITH VTD <Ref. to AT-49, WITH VTD, INSTALLATION, Reduction Driven Gear.>

16) Install the extension case to the transmission case. <Ref. to AT-36, INSTALLATION, Extension Case.>

17) Install the rear vehicle speed sensor.

**Tightening torque:**

**7 N·m (0.7 kgf·m, 5.1 ft·lb)**

18) Insert inhibitor switch and transmission connector into stay.

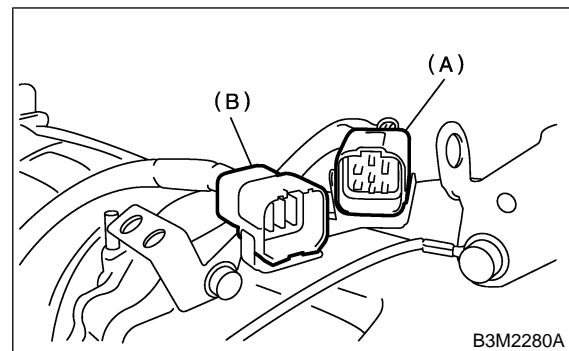

(A) Transmission harness

(B) Inhibitor switch harness

19) Install air breather hose. <Ref. to AT-28, INSTALLATION, Air Breather Hose.>

20) Install the oil cooler pipes. <Ref. to AT-30, INSTALLATION, Oil Cooler Pipes.>

21) Install the oil charger pipe with O-ring. <Ref. to AT-29, INSTALLATION, Oil Charger Pipe.>

# LOW AND REVERSE BRAKE

Automatic Transmission

22) Insert the input shaft while turning lightly by hand.

### CAUTION:

Be careful not to damage the bushing.

**Normal protrusion A:**

**50 — 55 mm (1.97 — 2.17 in)**

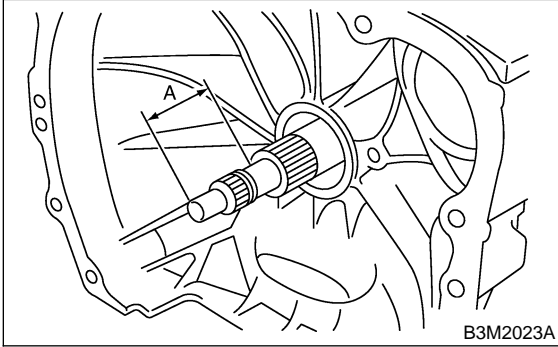

23) Install the torque converter clutch assembly.  
<Ref. to AT-35, INSTALLATION, Torque Converter Clutch Assembly.>

## C: INSPECTION

S510594A10

Check for the following.

- Drive plate facing for wear or damage
- Snap ring for wear and spring retainer for deformation

1) Inspect clearance and select retaining plate.

### NOTE:

Before measuring clearance, place the same thickness of shim on both sides to prevent retaining plate from tilting.

**Standard value:**

**0.7 — 1.2 mm (0.028 — 0.047 in)**

**Allowable limit:**

**2.2 mm (0.087 in)**

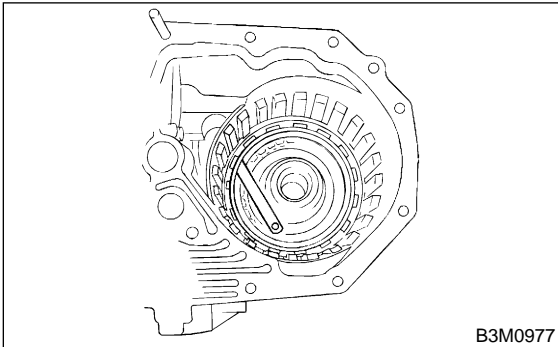

Available retaining plates	
Part No.	Thickness mm (in)
31667AA320	4.1 (0.161)
31667AA330	4.4 (0.173)
31667AA340	4.7 (0.185)
31667AA350	5.0 (0.197)
31667AA360	5.3 (0.209)
31667AA370	5.6 (0.220)
31667AA380	5.9 (0.232)

## 26. Low and Reverse Brake S510594

### A: REMOVAL S510594A18

- 1) Extract the torque converter clutch assembly. <Ref. to AT-35, REMOVAL, Torque Converter Clutch Assembly.>
- 2) Remove the input shaft.
- 3) Disconnect the air breather hose. <Ref. to AT-28, REMOVAL, Air Breather Hose.>
- 4) Disconnect transmission harness connector from stay.

**NOTE:**

Lift-up lever behind the connector and disconnect it from stay.

- 5) Disconnect inhibitor switch connector from stay.
- 6) Remove the oil charger pipe. <Ref. to AT-29, REMOVAL, Oil Charger Pipe.>
- 7) Remove the oil cooler inlet and outlet pipes. <Ref. to AT-30, REMOVAL, Oil Cooler Pipes.>
- 8) Separation of torque converter clutch case and transmission case. <Ref. to AT-58, REMOVAL, Torque Converter Clutch Case.>
- 9) Separate transmission case and extension case sections. <Ref. to AT-36, REMOVAL, Extension Case.>
- 10) Remove the reduction driven gear. WITHOUT VTD <Ref. to AT-48, WITHOUT VTD, REMOVAL, Reduction Driven Gear.> WITH VTD <Ref. to AT-48, WITH VTD, REMOVAL, Reduction Driven Gear.>
- 11) Remove the reduction drive gear. <Ref. to AT-51, REMOVAL, Reduction Drive Gear.>
- 12) Remove the oil pump housing. <Ref. to AT-62, REMOVAL, Oil Pump.>
- 13) Remove control valve assembly. <Ref. to AT-81, REMOVAL, Control Valve Body Assembly.>
- 14) Take out the high clutch and reverse clutch assembly. <Ref. to AT-87, REMOVAL, High Clutch and Reverse Clutch.>
- 15) Take out the thrust needle bearing, planetary gear assembly. <Ref. to AT-92, REMOVAL, Planetary Gear and Low Clutch.>
- 16) Take out 2-4 brake return spring, piston and piston retainer. <Ref. to AT-100, REMOVAL, 2-4 Brake.>
- 17) Remove one-way clutch inner race. <Ref. to AT-104, REMOVAL, One-way Clutch.>

- 18) Take out the low & reverse piston by applying compressed air.

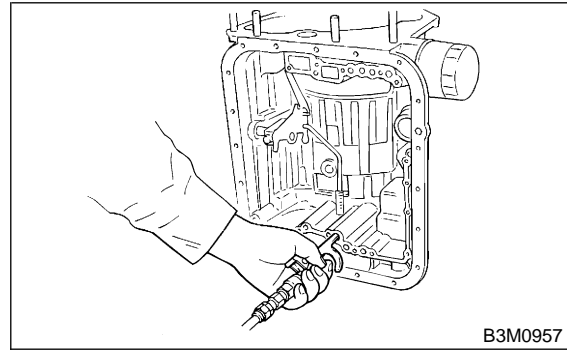

- 19) Take out the spring retainer, return spring and low & reverse piston.

### B: INSTALLATION S510594A11

- 1) Install the low and reverse piston.

**CAUTION:**

- Be careful not to tilt the piston when installing.
- Be careful not to damage the lip seal.

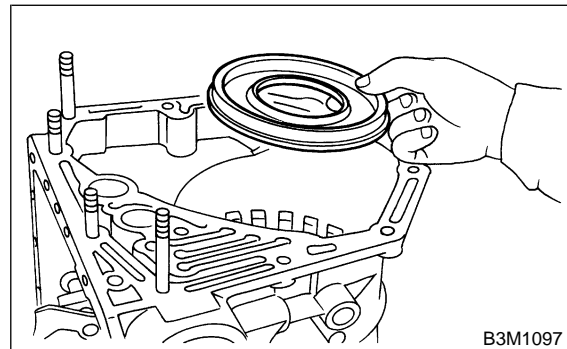

- 2) Install return spring.

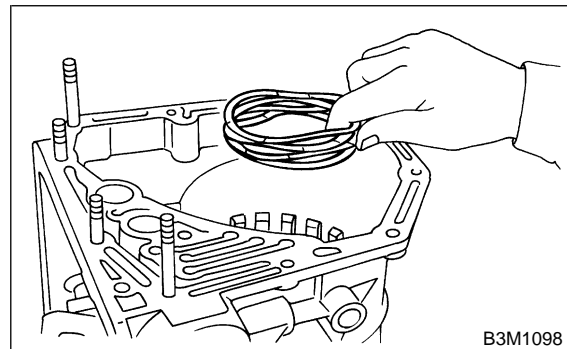



3) Install spring retainer.

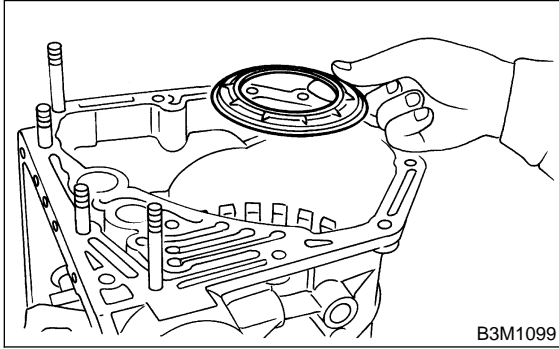

4) Install the one-way clutch inner race. <Ref. to AT-105, INSTALLATION, One-way Clutch.>

5) Install thrust needle bearing.

**NOTE:**

Place transmission case with the front facing up.

6) Installation of the low & reverse brake:  
Install dish plate, driven plates, drive plates, and a retaining plate, and secure with a snap ring.

**NOTE:**

Pay attention to the orientation of the dish plate.

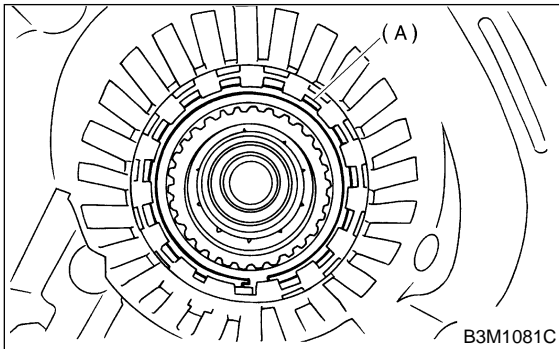

(A) Snap ring

7) Apply compressed air intermittently to check for operation.

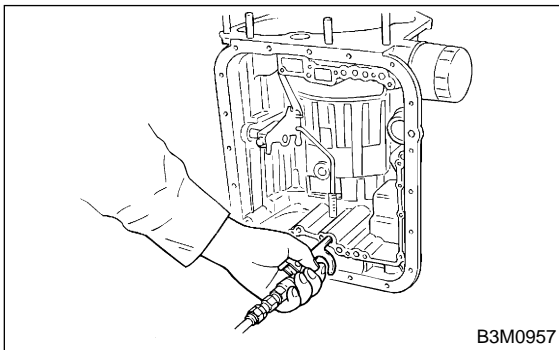

8) Check the clearance and select retaining plate. <Ref. to AT-110, INSPECTION, Low and Reverse Brake.>

9) Install 2-4 brake piston, retainer and return spring to transmission case. <Ref. to AT-101, INSTALLATION, 2-4 Brake.>

10) Install planetary gear and low clutch assembly to transmission case.

Install carefully while rotating the low clutch and planetary gear assembly slowly paying special attention not to damage the seal ring. <Ref. to AT-93, INSTALLATION, Planetary Gear and Low Clutch.>

11) Install the high clutch assembly. <Ref. to AT-88, INSTALLATION, High Clutch and Reverse Clutch.>

12) Install the oil pump housing assembly. <Ref. to AT-63, INSTALLATION, Oil Pump.>

13) Install the torque converter clutch case assembly to the transmission case assembly. <Ref. to AT-59, INSTALLATION, Torque Converter Clutch Case.>

14) Install reduction drive gear. <Ref. to AT-48, INSTALLATION, Reduction Drive Gear.>

15) Install reduction driven gear. WITHOUT VTD <Ref. to AT-48, WITHOUT VTD, INSTALLATION, Reduction Driven Gear.>

WITH VTD <Ref. to AT-49, WITH VTD, INSTALLATION, Reduction Driven Gear.>

16) Install the extension case to the transmission case. <Ref. to AT-36, INSTALLATION, Extension Case.>

17) Install the rear vehicle speed sensor.

**Tightening torque:**

**7 N·m (0.7 kgf·m, 5.1 ft·lb)**

18) Insert inhibitor switch and transmission connector into stay.

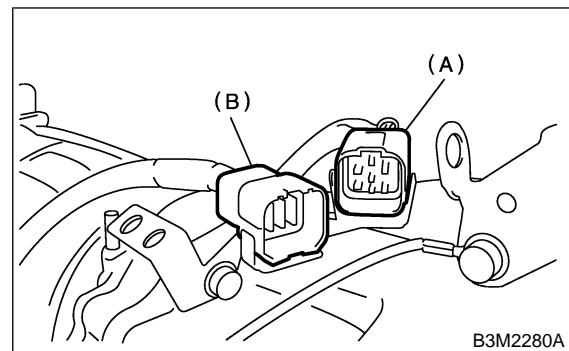

(A) Transmission harness  
(B) Inhibitor switch harness

19) Install air breather hose. <Ref. to AT-28, INSTALLATION, Air Breather Hose.>

20) Install the oil cooler pipes. <Ref. to AT-30, INSTALLATION, Oil Cooler Pipes.>

21) Install the oil charger pipe with O-ring. <Ref. to AT-29, INSTALLATION, Oil Charger Pipe.>

# LOW AND REVERSE BRAKE

Automatic Transmission

22) Insert the input shaft while turning lightly by hand.

## CAUTION:

Be careful not to damage the bushing.

**Normal protrusion A:**

**50 — 55 mm (1.97 — 2.17 in)**

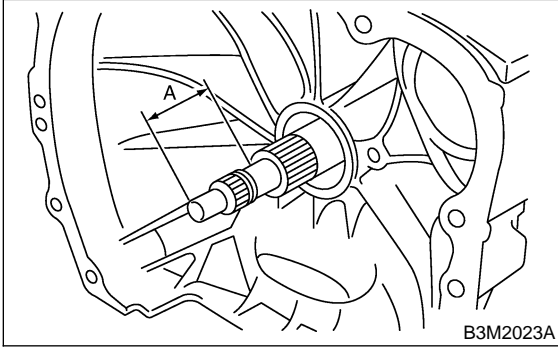

Available retaining plates	
Part No.	Thickness mm (in)
31667AA320	4.1 (0.161)
31667AA330	4.4 (0.173)
31667AA340	4.7 (0.185)
31667AA350	5.0 (0.197)
31667AA360	5.3 (0.209)
31667AA370	5.6 (0.220)
31667AA380	5.9 (0.232)

23) Install the torque converter clutch assembly.  
<Ref. to AT-35, INSTALLATION, Torque Converter Clutch Assembly.>

## C: INSPECTION

S510594A10

Check for the following.

- Drive plate facing for wear or damage
- Snap ring for wear and spring retainer for deformation

1) Inspect clearance and select retaining plate.

### NOTE:

Before measuring clearance, place the same thickness of shim on both sides to prevent retaining plate from tilting.

**Standard value:**

**0.7 — 1.2 mm (0.028 — 0.047 in)**

**Allowable limit:**

**2.2 mm (0.087 in)**

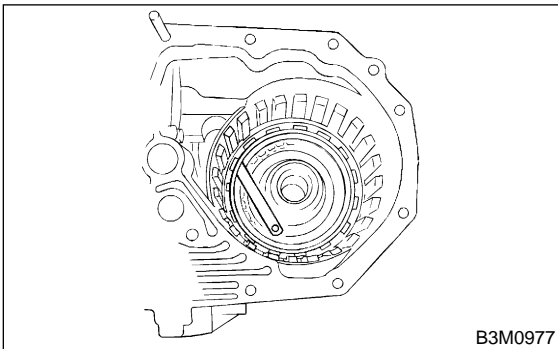

## 27. Transmission Control Device

S510214

### A: REMOVAL

S510214A18

- 1) Extract the torque converter clutch assembly. <Ref. to AT-35, REMOVAL, Torque Converter Clutch Assembly.>
- 2) Remove the input shaft.
- 3) Disconnect transmission harness connector from stay.

#### NOTE:

Lift-up lever behind the connector and disconnect it from stay.

- 4) Disconnect the air breather hoses. <Ref. to AT-28, REMOVAL, Air Breather Hose.>
- 5) Disconnect inhibitor switch connector from stay.
- 6) Wrap vinyl tape around the nipple attached to the air breather hose.
- 7) Remove pitching stopper bracket.
- 8) Remove the inhibitor switch.

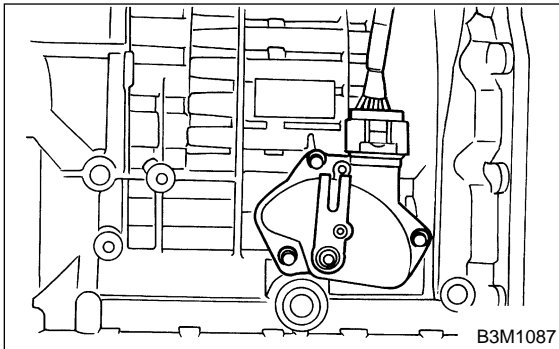

- 9) Remove control valve body assembly. <Ref. to AT-81, REMOVAL, Control Valve Body Assembly.>
- 10) Pull off the straight pin of manual plate.

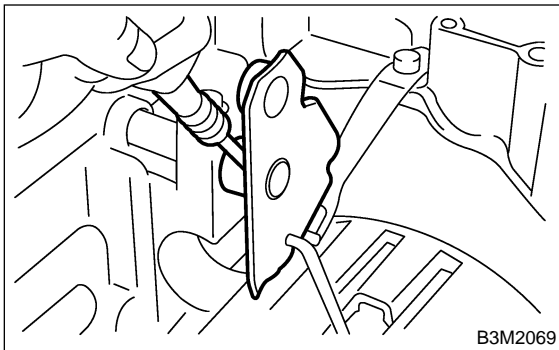

- 11) Remove bolts securing select lever, then remove select lever, manual plate and parking rod.

#### NOTE:

Be careful not to damage the lips of the press-fitted oil seal in the case.

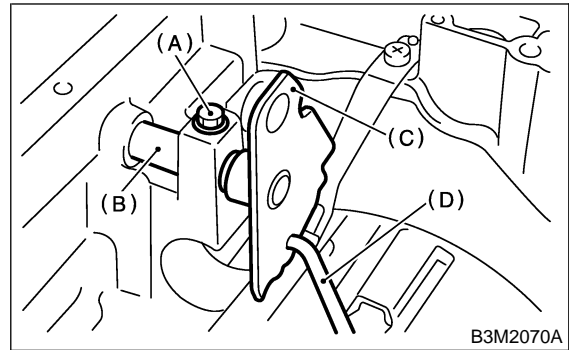

- (A) Bolt
- (B) Range select lever
- (C) Manual plate
- (D) Parking rod

- 12) Remove the detention spring.

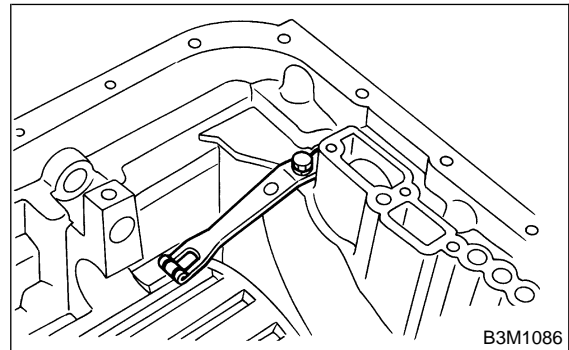

### B: INSTALLATION

S510214A11

- 1) Install detention spring to transmission case.

#### Tightening torque:

**6 N·m (0.6 kgf-m, 4.3 ft-lb)**

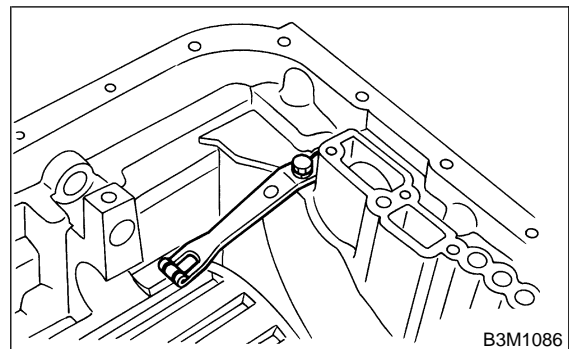

# TRANSMISSION CONTROL DEVICE

Automatic Transmission

2) Insert range select lever, and tighten bolt.

**Tightening torque:**

**6 N·m (0.6 kgf-m, 4.3 ft-lb)**

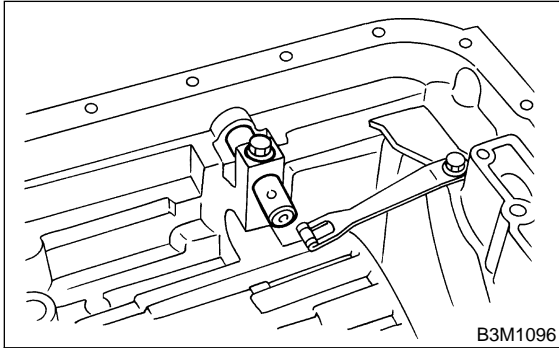

3) Insert manual plate and parking rod.

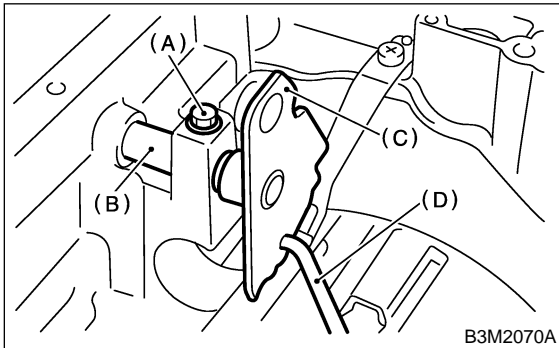

- (A) Bolt
- (B) Range select lever
- (C) Manual plate
- (D) Parking rod

4) Insert spring pin to manual plate.

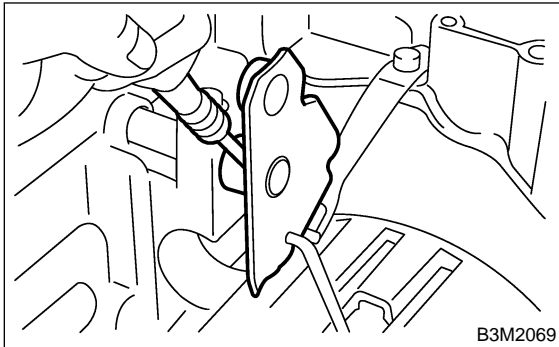

5) Install control valve assembly and oil pan. <Ref. to AT-82, INSTALLATION, Control Valve Body Assembly.>

6) Turn over the transmission case to its original position.

7) Install pitching stopper bracket.

**Tightening torque:**

**41 N·m (4.2 kgf-m, 30.4 ft-lb)**

8) Install inhibitor switch and adjust the inhibitor switch by referring to Supplement AT section.

9) Insert inhibitor switch and transmission connector into stay.

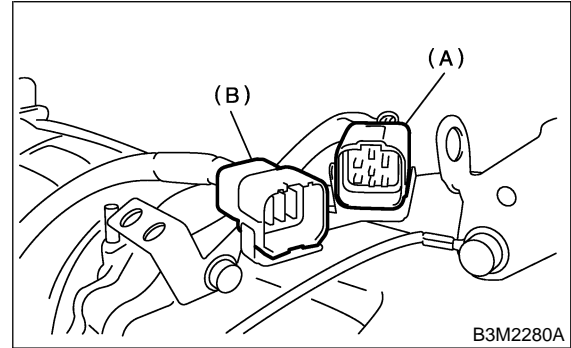

- (A) Transmission harness
- (B) Inhibitor switch harness

10) Install air breather hose. <Ref. to AT-28, INSTALLATION, Air Breather Hose.>

11) Insert the input shaft while turning lightly by hand.

**CAUTION:**

**Be careful not to damage the bushing.**

**Normal protrusion A:**

**50 — 55 mm (1.97 — 2.17 in)**

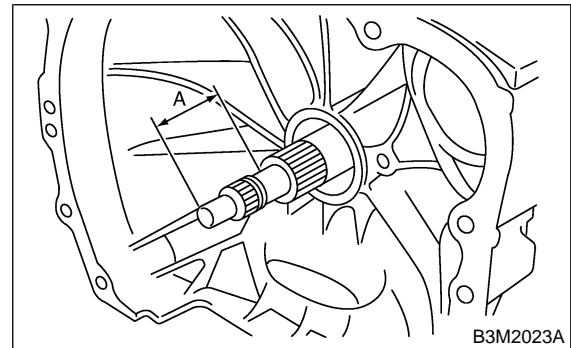

12) Install the torque converter clutch assembly. <Ref. to AT-35, INSTALLATION, Torque Converter Clutch Assembly.>

**C: INSPECTION** S510214A10

Make sure the manual lever and detention spring are not worn or otherwise damaged.

## 27. Transmission Control Device

S510214

### A: REMOVAL

S510214A18

- 1) Extract the torque converter clutch assembly. <Ref. to AT-35, REMOVAL, Torque Converter Clutch Assembly.>
- 2) Remove the input shaft.
- 3) Disconnect transmission harness connector from stay.

#### NOTE:

Lift-up lever behind the connector and disconnect it from stay.

- 4) Disconnect the air breather hoses. <Ref. to AT-28, REMOVAL, Air Breather Hose.>
- 5) Disconnect inhibitor switch connector from stay.
- 6) Wrap vinyl tape around the nipple attached to the air breather hose.
- 7) Remove pitching stopper bracket.
- 8) Remove the inhibitor switch.

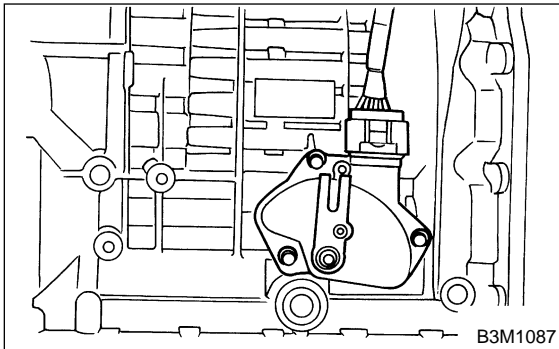

- 9) Remove control valve body assembly. <Ref. to AT-81, REMOVAL, Control Valve Body Assembly.>
- 10) Pull off the straight pin of manual plate.

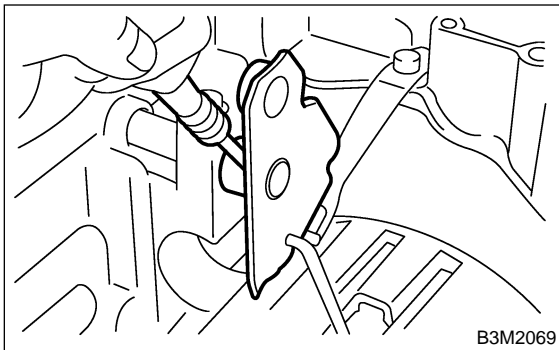

- 11) Remove bolts securing select lever, then remove select lever, manual plate and parking rod.

#### NOTE:

Be careful not to damage the lips of the press-fitted oil seal in the case.

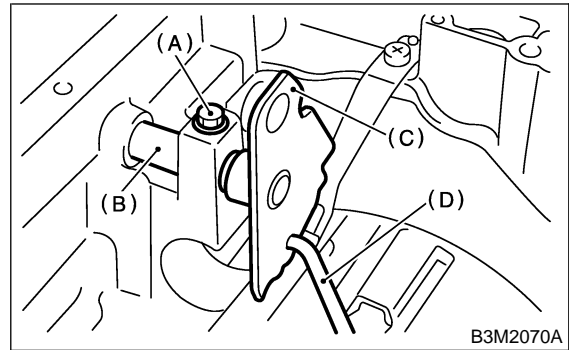

- (A) Bolt
- (B) Range select lever
- (C) Manual plate
- (D) Parking rod

- 12) Remove the detention spring.

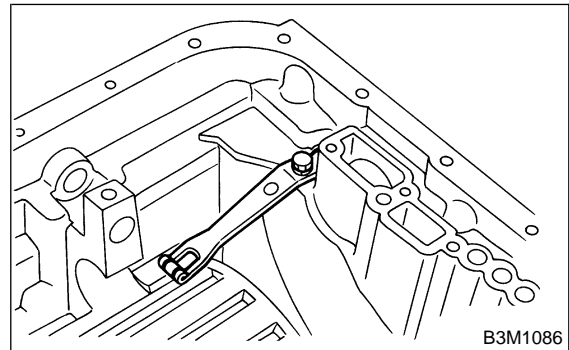

### B: INSTALLATION

S510214A11

- 1) Install detention spring to transmission case.

#### Tightening torque:

**6 N·m (0.6 kgf·m, 4.3 ft·lb)**

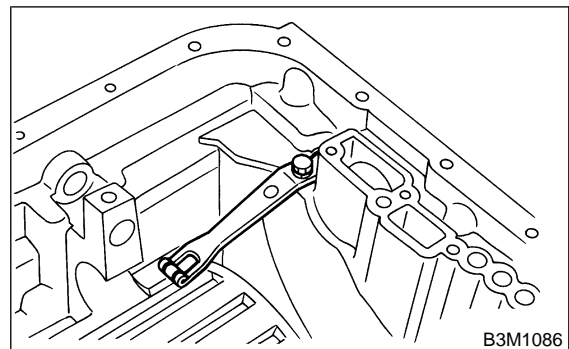

# TRANSMISSION CONTROL DEVICE

Automatic Transmission

2) Insert range select lever, and tighten bolt.

**Tightening torque:**

**6 N·m (0.6 kgf-m, 4.3 ft-lb)**

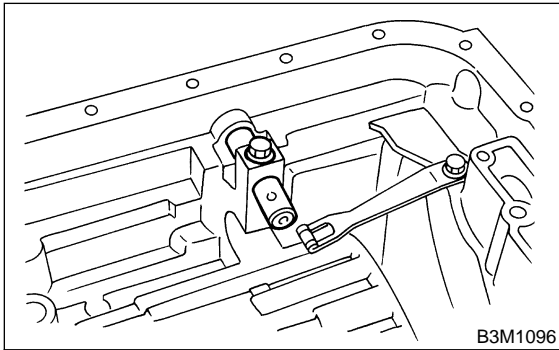

3) Insert manual plate and parking rod.

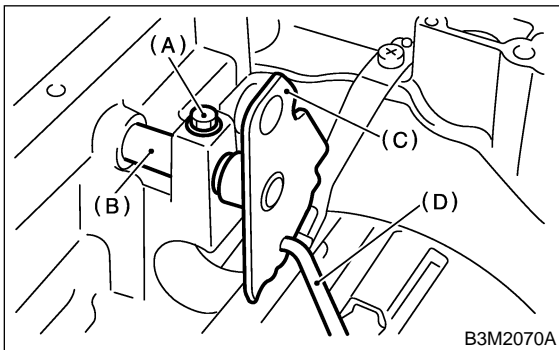

- (A) Bolt
- (B) Range select lever
- (C) Manual plate
- (D) Parking rod

4) Insert spring pin to manual plate.

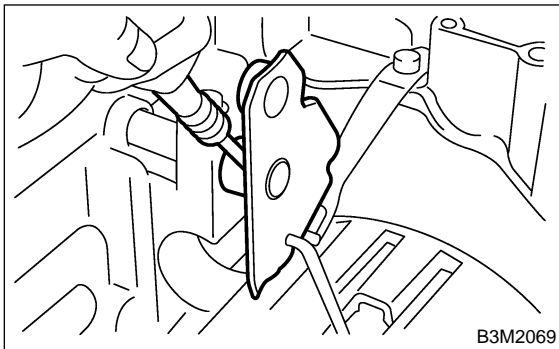

5) Install control valve assembly and oil pan. <Ref. to AT-82, INSTALLATION, Control Valve Body Assembly.>

6) Turn over the transmission case to its original position.

7) Install pitching stopper bracket.

**Tightening torque:**

**41 N·m (4.2 kgf-m, 30.4 ft-lb)**

8) Install inhibitor switch and adjust the inhibitor switch by referring to Supplement AT section.

9) Insert inhibitor switch and transmission connector into stay.

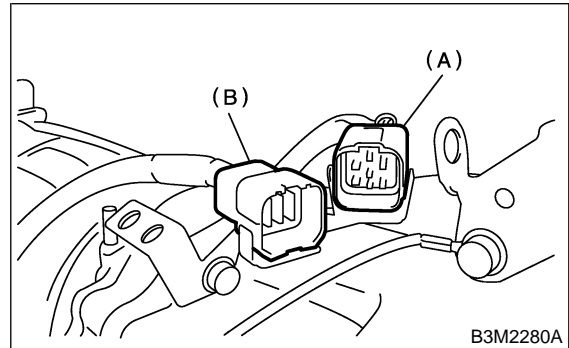

- (A) Transmission harness
- (B) Inhibitor switch harness

10) Install air breather hose. <Ref. to AT-28, INSTALLATION, Air Breather Hose.>

11) Insert the input shaft while turning lightly by hand.

**CAUTION:**

**Be careful not to damage the bushing.**

**Normal protrusion A:**

**50 — 55 mm (1.97 — 2.17 in)**

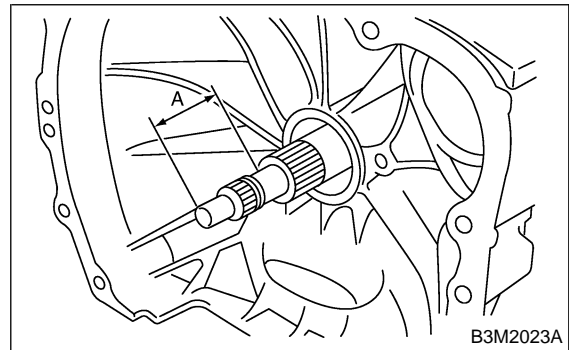

12) Install the torque converter clutch assembly. <Ref. to AT-35, INSTALLATION, Torque Converter Clutch Assembly.>

**C: INSPECTION** S510214A10

Make sure the manual lever and detention spring are not worn or otherwise damaged.