

# GENERAL DESCRIPTION

Automatic Transmission

## 1. General Description S510001

### A: SPECIFICATIONS S510001E49

#### 1. DRIVE PLATE AND DRIVEN PLATE S510001E4901

Plate number of high clutch	1.6 L	3
	2.0 L	4
	2.0 L TURBO	5
	2.5 L	4
	3.0 L	5
Plate number of reverse clutch	1.6 L	1
	2.0 L	2
	2.0 L TURBO	2
	2.5 L	2
	3.0 L	2
Plate number of 2-4 brake	1.6 L	2
	2.0 L	3
	2.0 L TURBO	4
	2.5 L	3
	3.0 L	4
Plate number of low clutch	1.6 L	4
	2.0 L	4
	2.0 L TURBO	7
	2.5 L	6
	3.0 L	7
Plate number of low and reverse brake	1.6 L	4
	2.0 L	4
	2.0 L TURBO	7
	2.5 L	6
	3.0 L	7
Plate number of transfer clutch	1.6 L	4
	2.0 L	4
	2.0 L TURBO (Without VTD)	6
	2.0 L TURBO (With VTD)	3
	2.5 L (Without VTD)	5
	2.5 L (With VTD)	3
	3.0 L (Without VTD)	6
	3.0 L (With VTD)	3

## 2. AUTOMATIC TRANSMISSION FLUID CAPACITY S510001E4902

Dexron III type Automatic transmission fluid	
1.6 L, 2.0 L	8.4 — 8.7 ℓ (8.9 — 9.2 US qt, 7.4 — 7.7 Imp qt)
2.0 L TURBO, 2.5 L, 3.0 L	9.3 — 9.6 ℓ (9.8 — 10.1 US qt, 8.2 — 8.4 Imp qt)

## 3. FRONT DIFFERENTIAL OIL CAPACITY S510001E4903

Recommended oil	Oil capacity
GL-5	1.1 — 1.2 ℓ (1.2 — 1.3 US qt, 1.0 — 1.1 Imp qt)

# GENERAL DESCRIPTION

Automatic Transmission

---

MEMO:

# GENERAL DESCRIPTION

Automatic Transmission

## B: COMPONENT SS10001A05

### 1. TORQUE CONVERTER CLUTCH AND CASE SS10001A0501

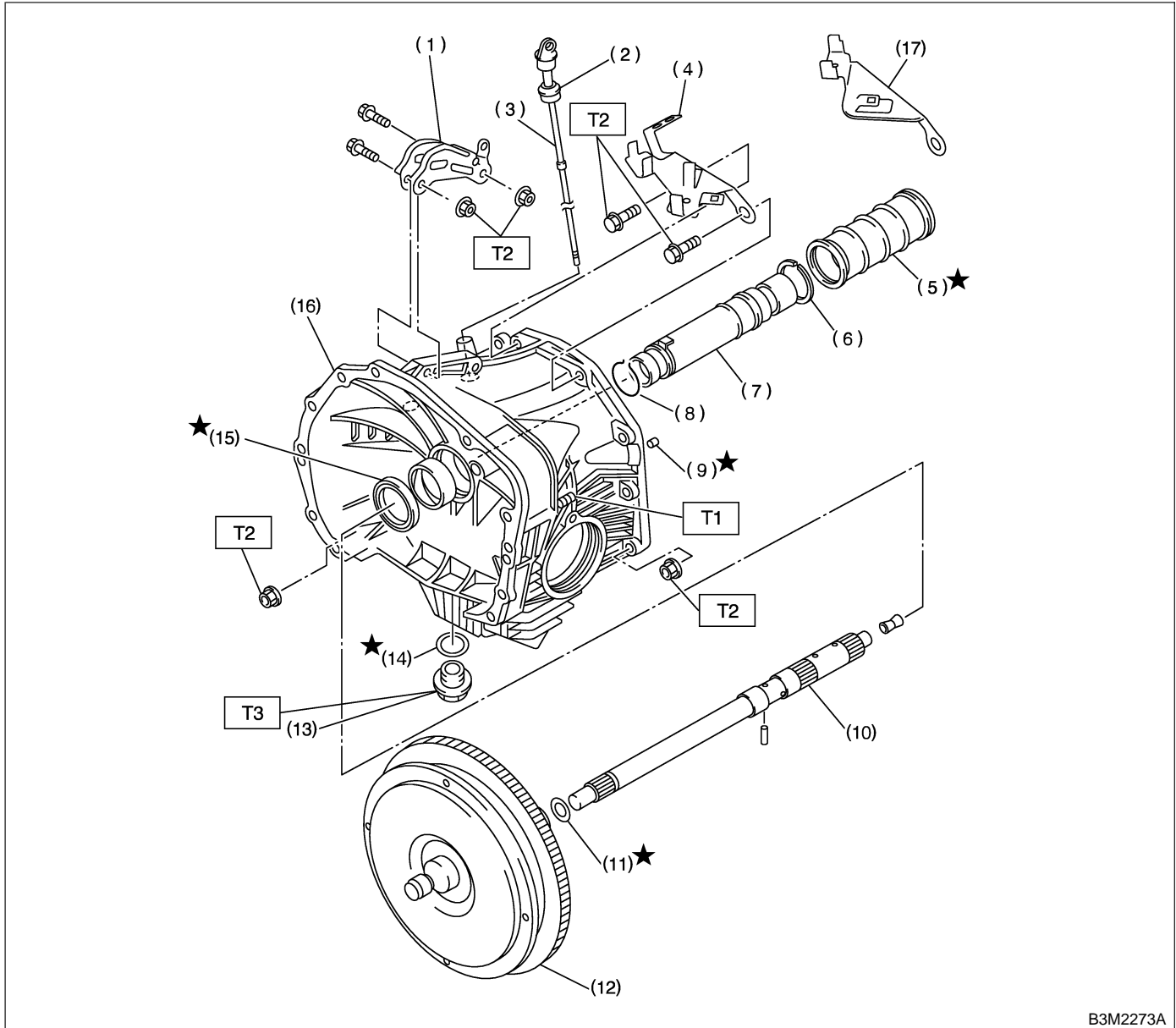

- (1) Pitching stopper bracket
- (2) O-ring
- (3) Differential oil level gauge
- (4) Stay (Except for Legacy)
- (5) Seal pipe
- (6) Seal ring
- (7) Oil pump shaft
- (8) Clip

- (9) Oil drain pipe
- (10) Input shaft
- (11) O-ring
- (12) Torque converter clutch ASSY
- (13) Drain plug
- (14) Gasket
- (15) Oil seal
- (16) Torque converter clutch case

- (17) Stay (For Legacy)

**Tightening torque: N·m (kgf·m, ft·lb)**

**T1: 18 (1.8, 13.0)**

**T2: 41 (4.2, 30.4)**

**T3: 44 (4.5, 32.5)**

## 2. OIL PUMP SS10001A0502

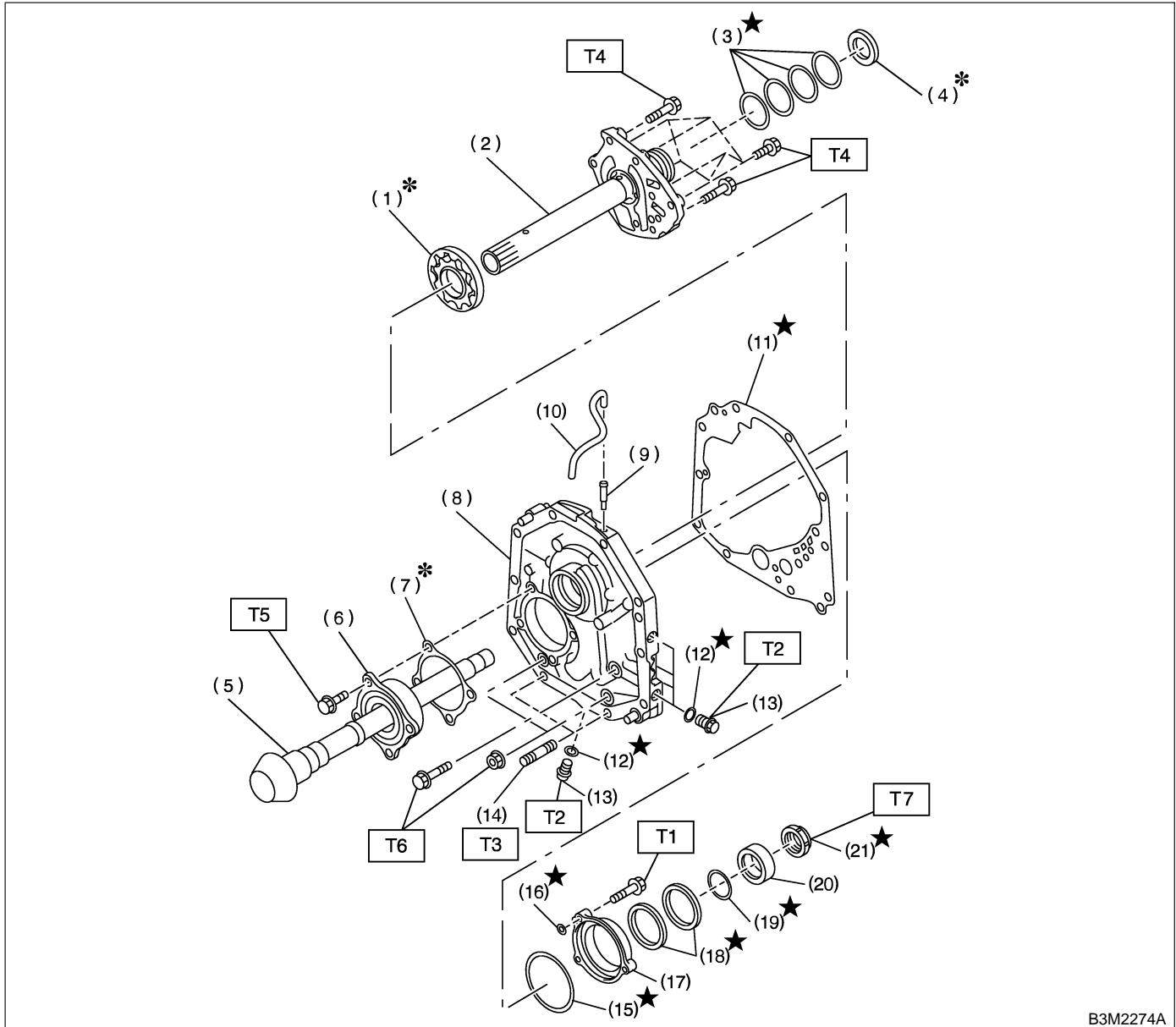

B3M2274A

- |                           |                          |
|---------------------------|--------------------------|
| (1) Oil pump rotor        | (12) O-ring              |
| (2) Oil pump cover        | (13) Test plug           |
| (3) Seal ring             | (14) Stud bolt           |
| (4) Thrust needle bearing | (15) O-ring              |
| (5) Drive pinion shaft    | (16) O-ring              |
| (6) Roller bearing        | (17) Oil seal retainer   |
| (7) Shim                  | (18) Oil seal            |
| (8) Oil pump housing      | (19) O-ring              |
| (9) Nipple                | (20) Drive pinion collar |
| (10) Air breather hose    | (21) Lock nut            |
| (11) Gasket               |                          |

**Tightening torque: N·m (kgf·m, ft·lb)**

- T1: 7 (0.7, 5.1)**  
**T2: 13 (1.3, 9.4)**  
**T3: 18 (1.8, 13.0)**  
**T4: 25 (2.5, 18.1)**  
**T5: 40 (4.1, 30)**  
**T6: 42 (4.3, 31)**  
**T7: 116 (11.8, 85)**

# GENERAL DESCRIPTION

Automatic Transmission

## 3. TRANSMISSION CASE AND CONTROL DEVICE

SS10001A0503

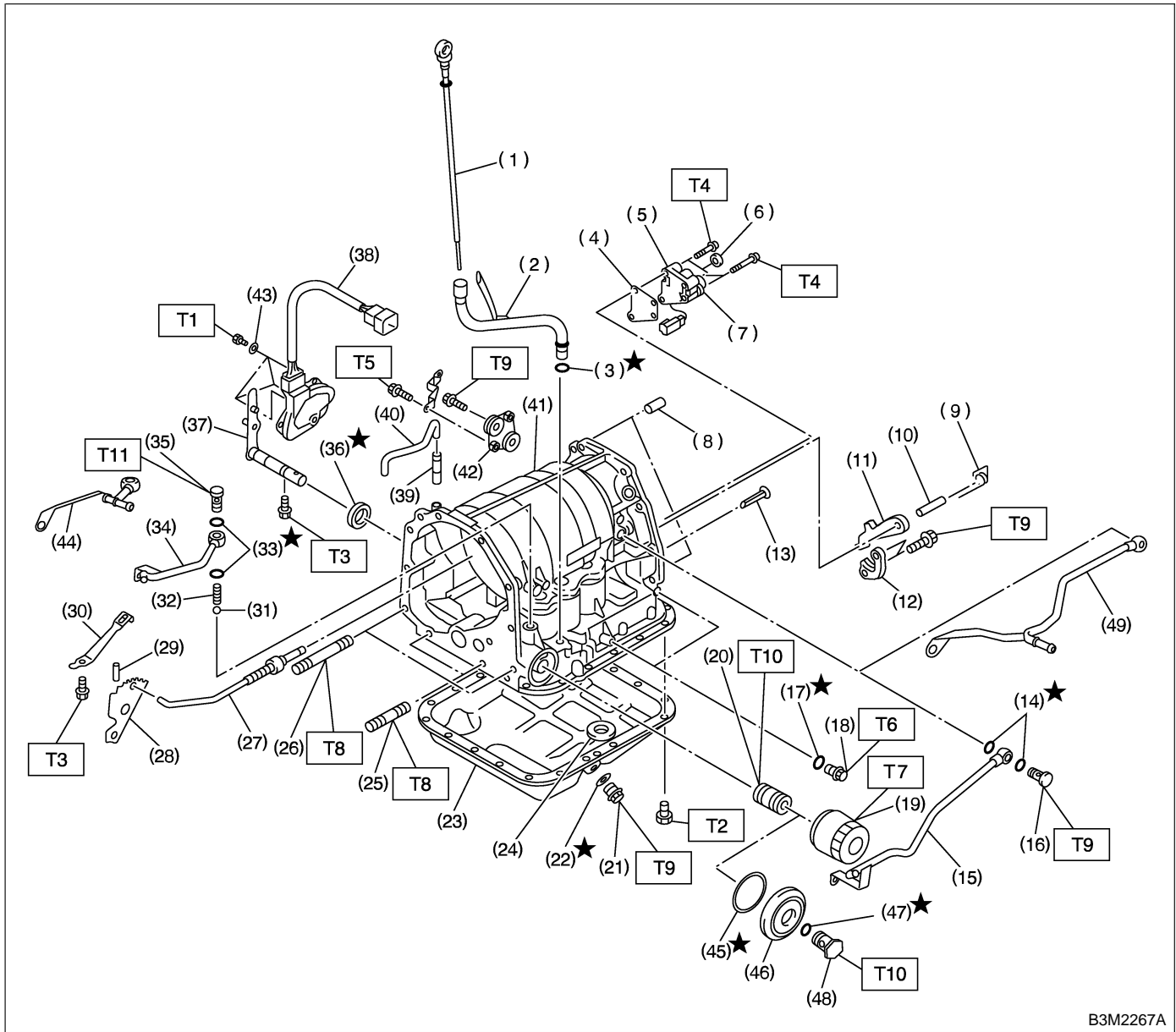

B3M2267A

# GENERAL DESCRIPTION

Automatic Transmission

---

(1) ATF level gauge	(22) Gasket	(43) Washer
(2) ATF charger pipe	(23) Oil pan	(44) Outlet pipe (Except for Forester)
(3) O-ring	(24) Magnet	(45) O-ring (3.0 L model)
(4) Transfer valve plate	(25) Stud bolt (Short)	(46) Cover (3.0 L model)
(5) Transfer valve ASSY	(26) Stud bolt (Long)	(47) Gasket (3.0 L model)
(6) Transfer clutch seal	(27) Parking rod	(48) Union screw (3.0 L model)
(7) Transfer duty solenoid	(28) Manual plate	(49) Inlet pipe (Except for Forester)
(8) Straight pin	(29) Spring pin	
(9) Return spring	(30) Detention spring	<b><i>Tightening torque: N·m (kgf·m, ft·lb)</i></b>
(10) Shaft	(31) Ball	<b><i>T1: 3.4 (0.35, 2.5)</i></b>
(11) Parking pawl	(32) Spring	<b><i>T2: 5 (0.5, 3.6)</i></b>
(12) Parking support	(33) Gasket	<b><i>T3: 6 (0.6, 4)</i></b>
(13) Inlet filter	(34) Outlet pipe (For Forester)	<b><i>T4: 8 (0.8, 6)</i></b>
(14) Gasket	(35) Union screw	<b><i>T5: 12 (1.2, 8.7)</i></b>
(15) Inlet pipe (Except for Forester)	(36) Oil seal	<b><i>T6: 13 (1.3, 10)</i></b>
(16) Union screw	(37) Select lever	<b><i>T7: 14 (1.4, 10)</i></b>
(17) O-ring	(38) Inhibitor switch ASSY	<b><i>T8: 18 (1.8, 13)</i></b>
(18) Test plug	(39) Nipple	<b><i>T9: 25 (2.6, 18)</i></b>
(19) Oil filter (Except 3.0 L model)	(40) Air breather hose	<b><i>T10: 44 (4.5, 32)</i></b>
(20) Oil filter stud bolt	(41) Transmission case	
(21) Drain plug	(42) Plate ASSY	

---

# GENERAL DESCRIPTION

Automatic Transmission

## 4. CONTROL VALVE AND HARNESS ROUTING

SS10001A0504

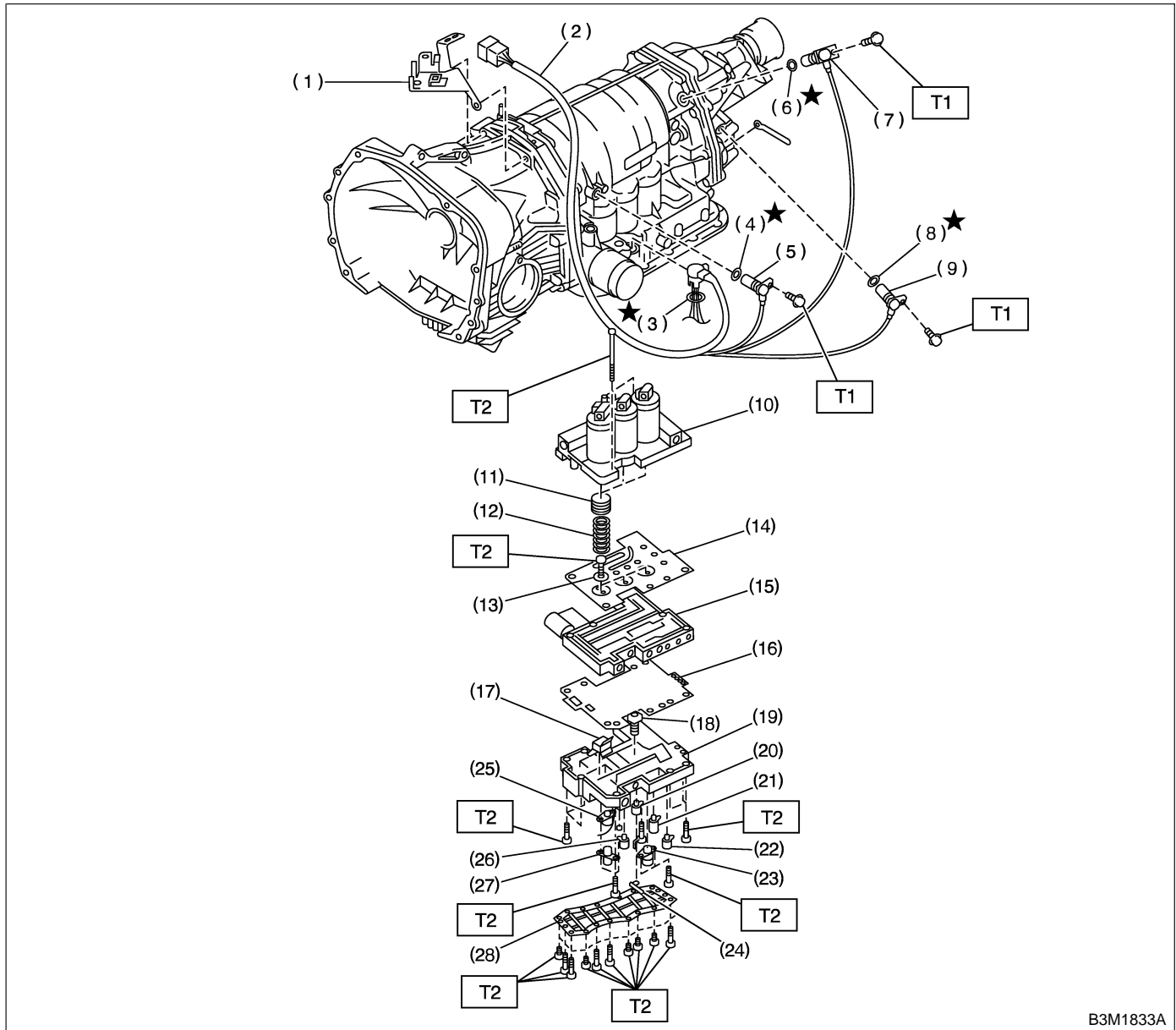

- (1) Stay
- (2) Transmission harness
- (3) O-ring
- (4) O-ring
- (5) Torque converter turbine speed sensor
- (6) O-ring
- (7) Front vehicle speed sensor
- (8) O-ring
- (9) Rear vehicle speed sensor
- (10) Upper valve body
- (11) Accumulator piston

- (12) Accumulator spring
- (13) Side plate
- (14) Separate plate
- (15) Middle valve body
- (16) Separate plate
- (17) Fluid filter
- (18) Fluid filter
- (19) Lower valve body
- (20) Shift solenoid 2
- (21) Shift solenoid 1
- (22) 2-4 brake timing solenoid
- (23) 2-4 brake duty solenoid

- (24) ATF temperature sensor
- (25) Line pressure duty solenoid
- (26) Low clutch timing solenoid
- (27) Lock-up duty solenoid
- (28) Oil strainer

**Tightening torque: N·m (kgf·m, ft·lb)**

**T1: 7 (0.7, 5.1)**

**T2: 8 (0.8, 5.8)**

## 5. HIGH CLUTCH AND REVERSE CLUTCH

S510001A0505

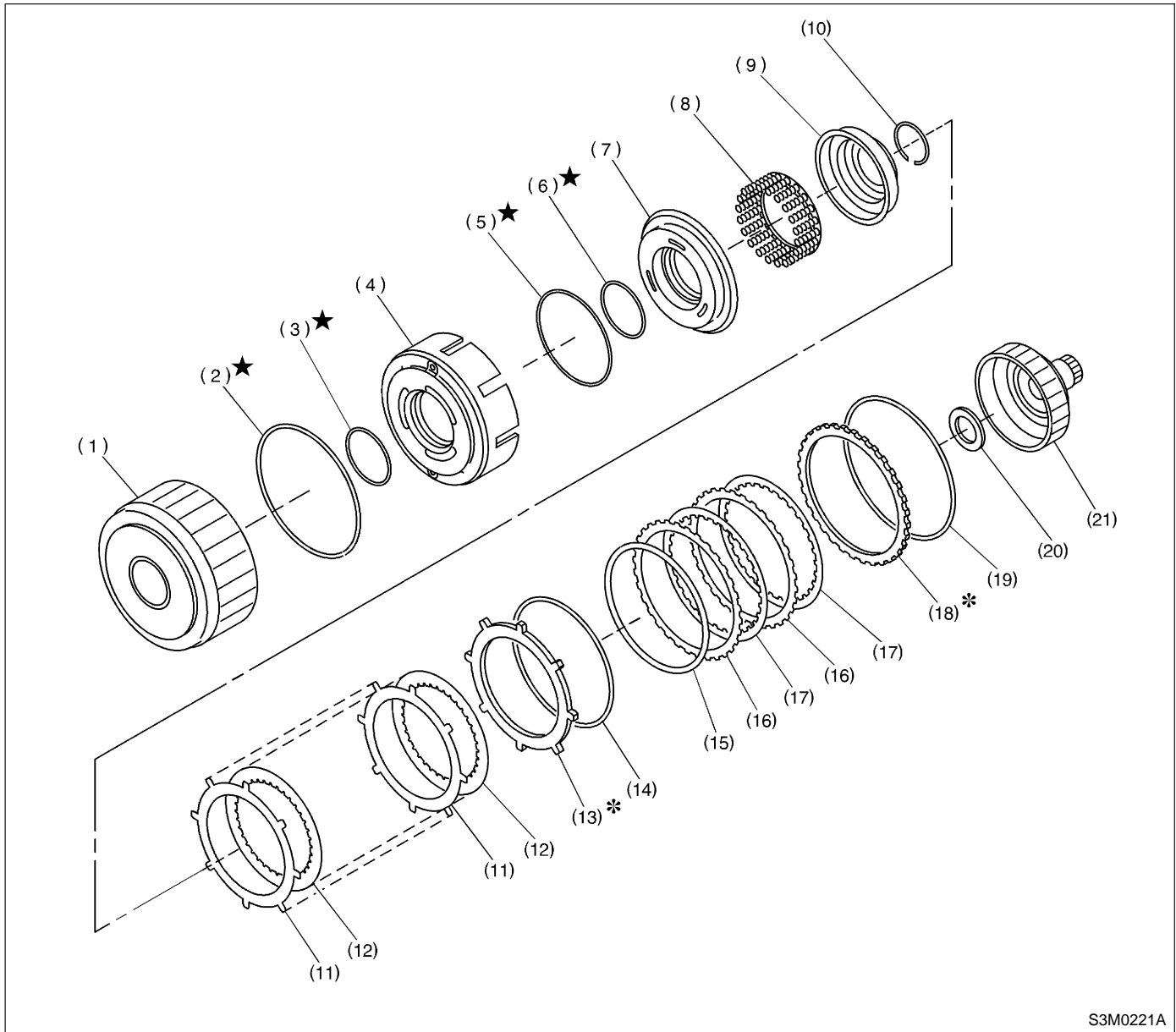

S3M0221A

- |                           |                      |                            |
|---------------------------|----------------------|----------------------------|
| (1) High clutch drum      | (8) Spring retainer  | (15) Dish plate            |
| (2) Lip seal              | (9) Cover            | (16) Driven plate          |
| (3) Lathe cut seal ring   | (10) Snap ring       | (17) Drive plate           |
| (4) Reverse clutch piston | (11) Driven plate    | (18) Retaining plate       |
| (5) Lathe cut seal ring   | (12) Drive plate     | (19) Snap ring             |
| (6) Lathe cut seal ring   | (13) Retaining plate | (20) Thrust needle bearing |
| (7) High clutch piston    | (14) Snap ring       | (21) High clutch hub       |



# GENERAL DESCRIPTION

Automatic Transmission

## 6. PLANETARY GEAR AND 2-4 BRAKE

S510001A0506

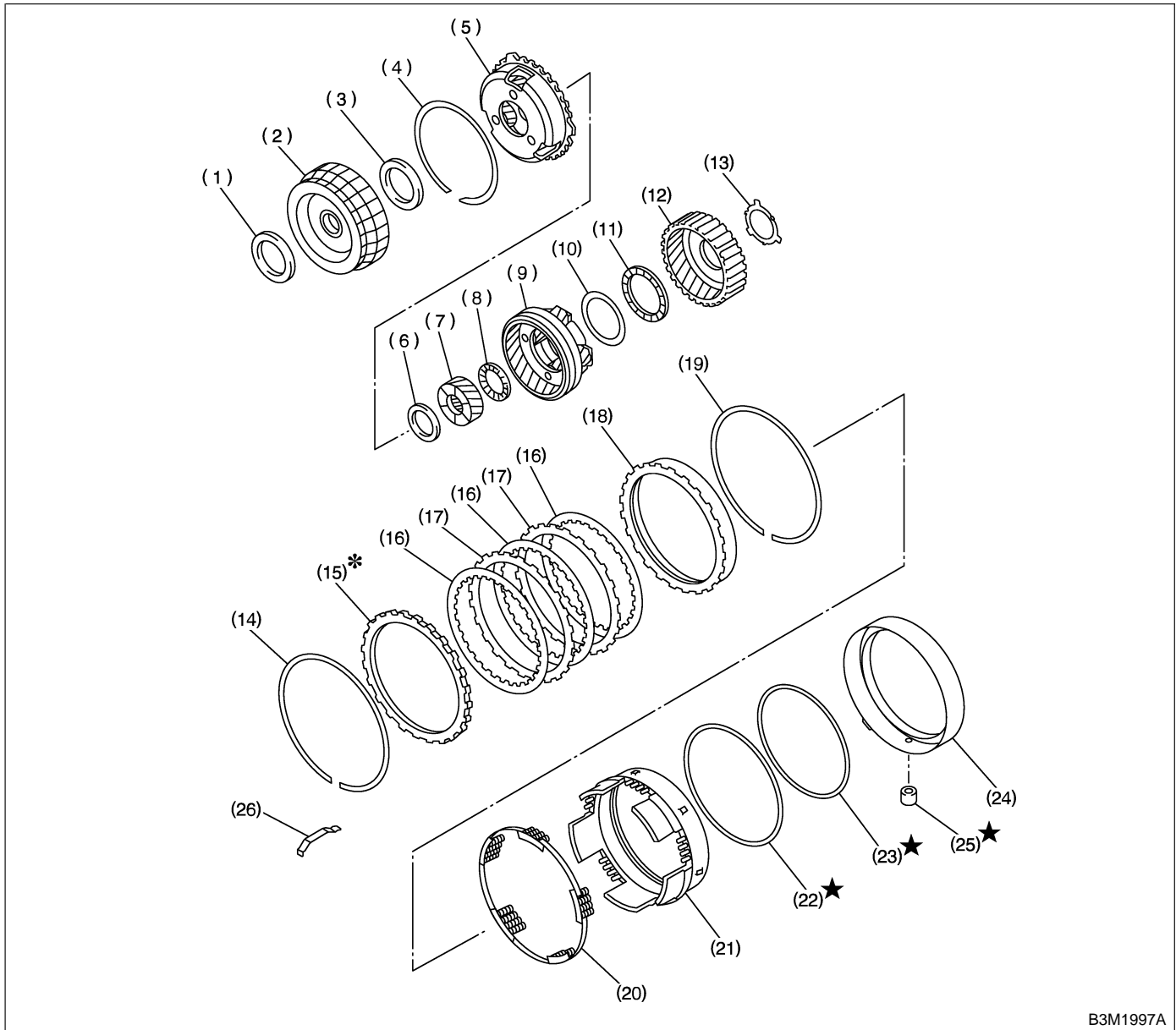

B3M1997A

- |                             |                            |                                |
|-----------------------------|----------------------------|--------------------------------|
| (1) Thrust needle bearing   | (10) Washer                | (19) Snap ring                 |
| (2) Front sun gear          | (11) Thrust needle bearing | (20) Spring retainer           |
| (3) Thrust needle bearing   | (12) Rear internal gear    | (21) 2-4 brake piston          |
| (4) Snap ring               | (13) Washer                | (22) Lathe cut seal ring       |
| (5) Front planetary carrier | (14) Snap ring             | (23) Lathe cut seal ring       |
| (6) Thrust needle bearing   | (15) Retaining plate       | (24) 2-4 brake piston retainer |
| (7) Rear sun gear           | (16) Drive plate           | (25) 2-4 brake seal            |
| (8) Thrust needle bearing   | (17) Driven plate          | (26) Leaf spring               |
| (9) Rear planetary carrier  | (18) Pressure rear plate   |                                |

## 7. LOW CLUTCH AND LOW & REVERSE BRAKE

SS10001A0507

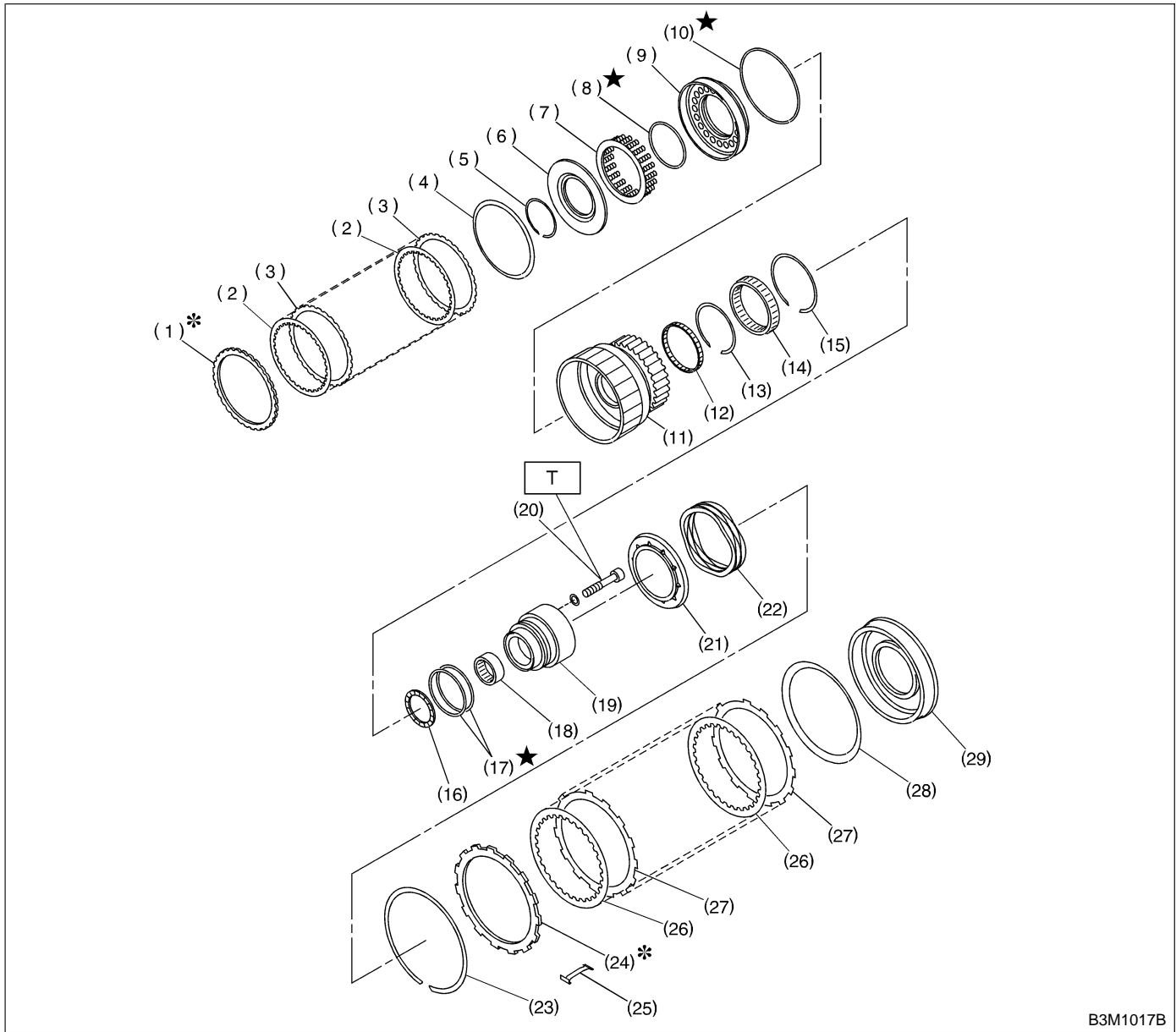

B3M1017B

- |                          |                                |                                   |
|--------------------------|--------------------------------|-----------------------------------|
| (1) Retaining plate      | (12) Needle bearing            | (23) Snap ring                    |
| (2) Drive plate          | (13) Inner snap ring           | (24) Retaining plate              |
| (3) Driven plate         | (14) One-way clutch            | (25) Leaf spring                  |
| (4) Dish plate           | (15) Outer snap ring           | (26) Drive plate                  |
| (5) Snap ring            | (16) Thrust needle bearing     | (27) Driven plate                 |
| (6) Cover                | (17) Seal ring                 | (28) Dish plate                   |
| (7) Spring retainer      | (18) Needle bearing            | (29) Low and reverse brake piston |
| (8) Lathe cut seal ring  | (19) One-way clutch inner race |                                   |
| (9) Low clutch piston    | (20) Socket bolt               |                                   |
| (10) Lathe cut seal ring | (21) Spring retainer           |                                   |
| (11) Low clutch drum     | (22) Return spring             |                                   |

**Tightening torque: N·m (kgf·m, ft·lb)**  
**T: 25 (2.5, 18.1)**

# GENERAL DESCRIPTION

Automatic Transmission

## 8. REDUCTION GEAR WITHOUT VTD

S510001A0508

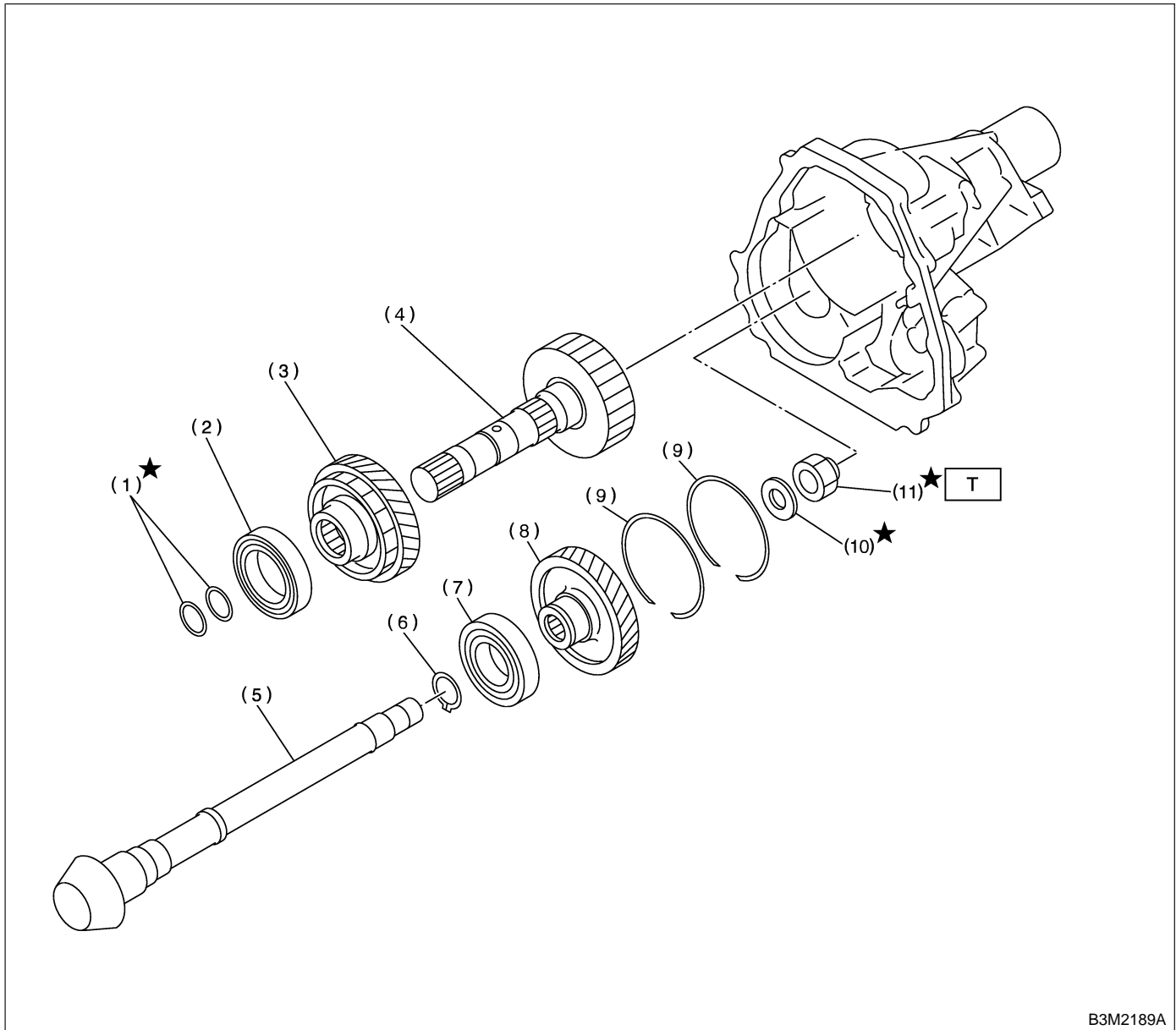

B3M2189A

- (1) Seal ring
- (2) Ball bearing
- (3) Reduction drive gear
- (4) Reduction drive shaft
- (5) Drive pinion shaft

- (6) Snap ring
- (7) Ball bearing
- (8) Reduction driven gear
- (9) Snap ring (Legacy 2.5 L US model and 3.0 L model)

- (10) Washer
- (11) Lock nut

**Tightening torque: N·m (kgf·m, ft·lb)**  
**T: 100 (10.2, 73.8)**

## 9. REDUCTION GEAR WITH VTD S510001A0509

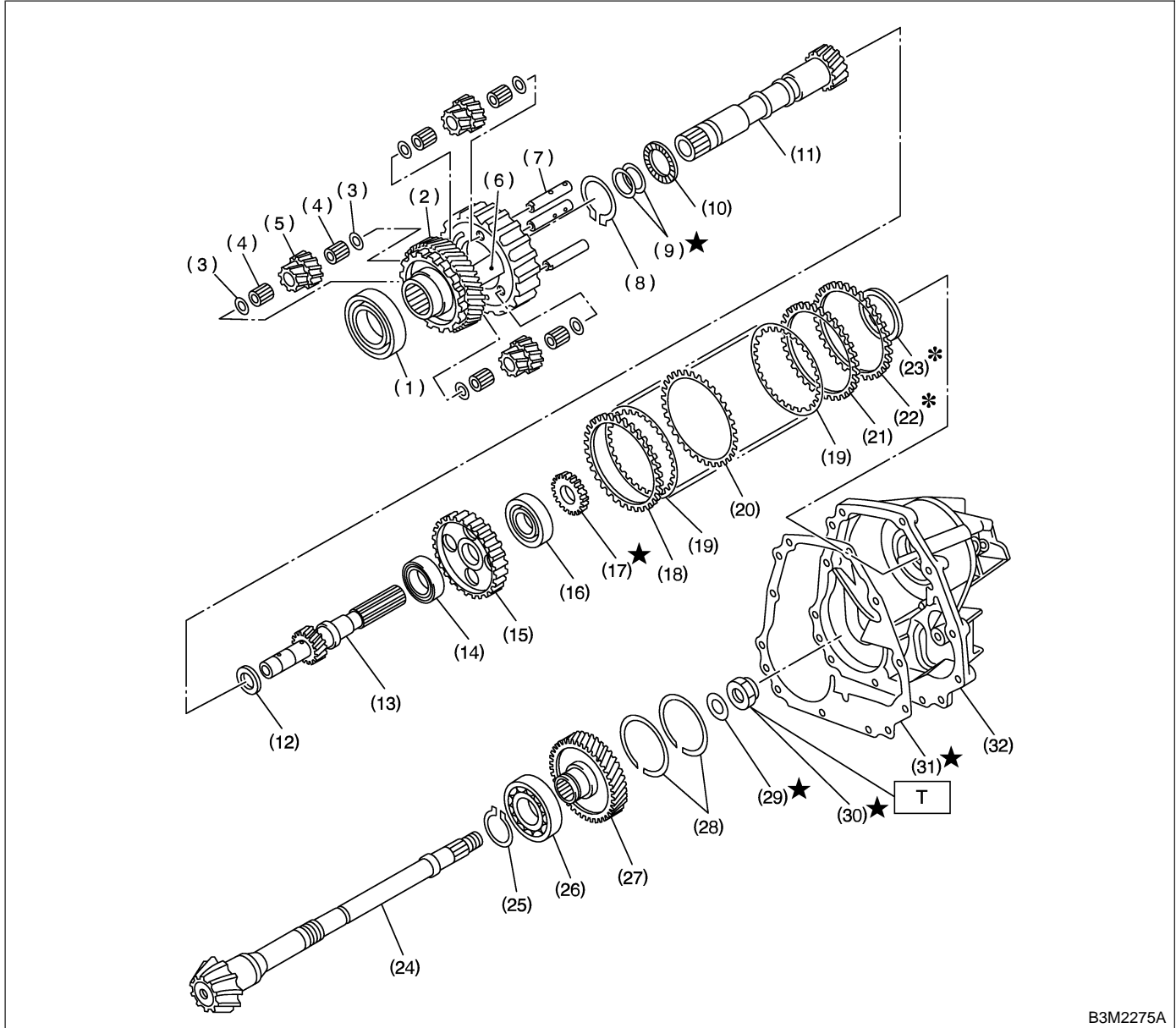

B3M2275A

- |                            |                                   |                                                        |
|----------------------------|-----------------------------------|--------------------------------------------------------|
| (1) Ball bearing           | (14) Ball bearing                 | (27) Reduction driven gear                             |
| (2) Reduction drive gear   | (15) Multi-plate clutch (LSD) hub | (28) Snap ring (Legacy 2.5 L US model and 3.0 L model) |
| (3) Washer                 | (16) Ball bearing                 | (29) Lock washer                                       |
| (4) Needle bearing         | (17) Revolution gear              | (30) Lock nut                                          |
| (5) Pinion gear            | (18) Driven plate (Thicker)       | (31) Gasket                                            |
| (6) Carrier                | (19) Drive plate                  | (32) Extension case                                    |
| (7) Planetary pinion shaft | (20) Driven plate (Thinner)       |                                                        |
| (8) Snap ring              | (21) Driven plate (Thicker)       |                                                        |
| (9) Seal ring              | (22) Adjust plate                 |                                                        |
| (10) Thrust needle bearing | (23) Rear drive shaft shim        |                                                        |
| (11) Intermediate shaft    | (24) Drive pinion shaft           |                                                        |
| (12) Thrust washer         | (25) Snap ring                    |                                                        |
| (13) Rear drive shaft      | (26) Ball bearing                 |                                                        |

---

**Tightening torque: N·m (kgf·m, ft·lb)**  
**T: 100 (10.2, 73.8)**

---

# GENERAL DESCRIPTION

Automatic Transmission

## 10. DIFFERENTIAL GEAR S510001A0510

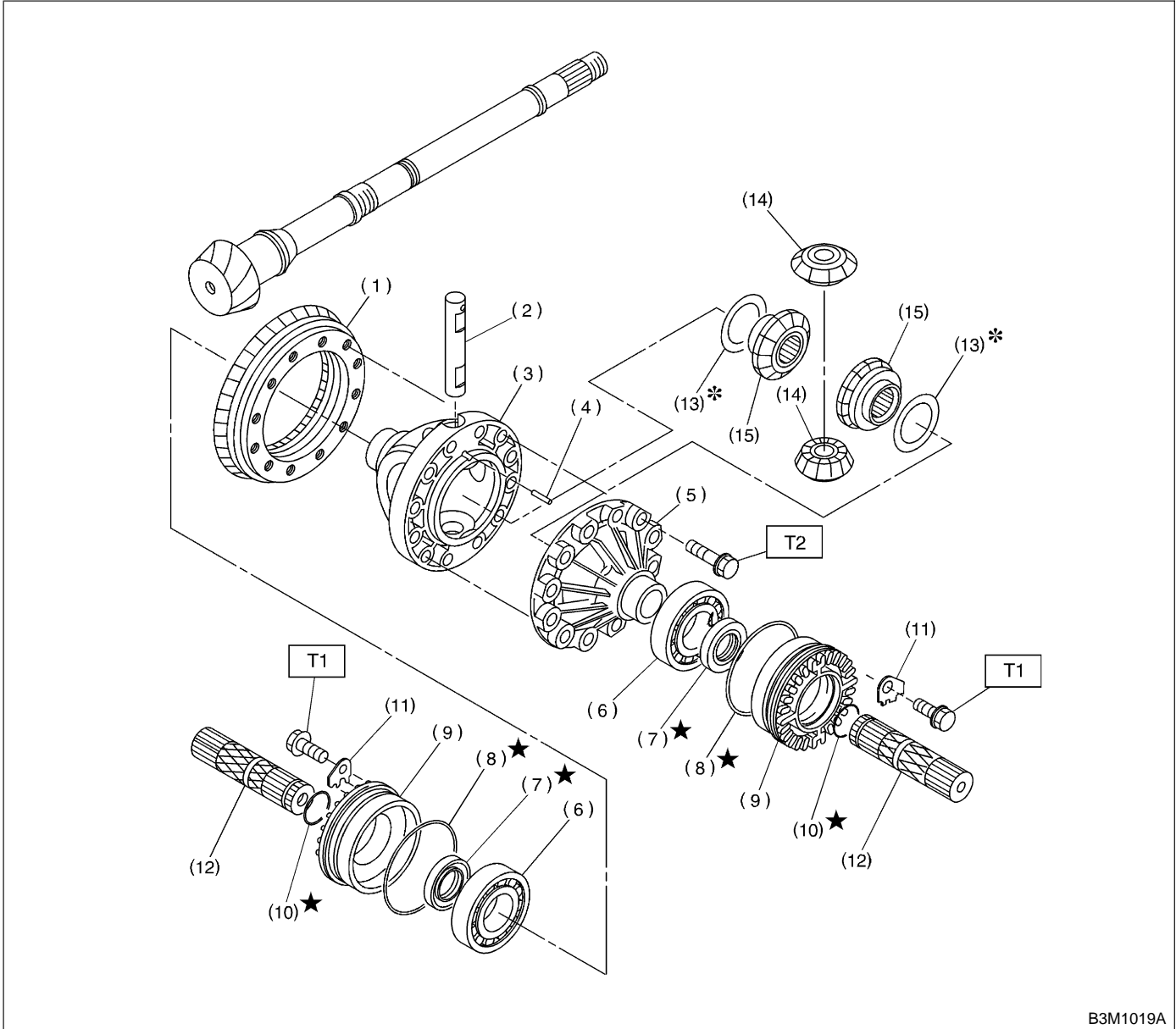

B3M1019A

- |                            |                                |
|----------------------------|--------------------------------|
| (1) Crown gear             | (8) O-ring                     |
| (2) Pinion shaft           | (9) Differential side retainer |
| (3) Differential case (RH) | (10) Circlip                   |
| (4) Straight pin           | (11) Lock plate                |
| (5) Differential case (LH) | (12) Axle shaft                |
| (6) Taper roller bearing   | (13) Washer                    |
| (7) Oil seal               | (14) Differential bevel pinion |

- (15) Differential bevel gear

**Tightening torque: N·m (kgf·m, ft·lb)**

**T1: 25 (2.5, 18.1)**

**T2: 62 (6.3, 45.6)**

## 11. TRANSFER AND EXTENSION CASE WITHOUT VTD

S510001A0511

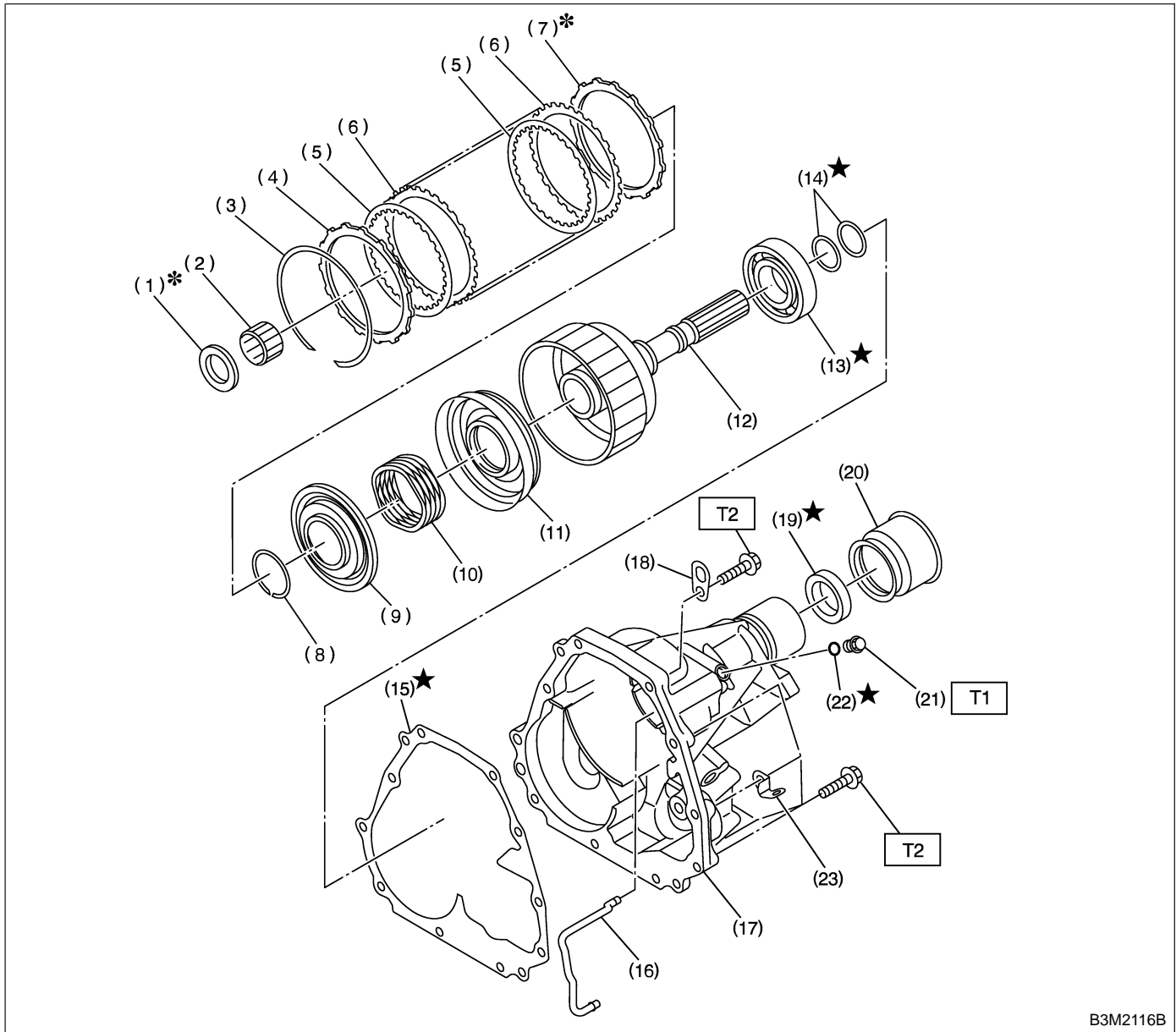

B3M2116B

- (1) Thrust needle bearing
- (2) Needle bearing
- (3) Snap ring
- (4) Pressure plate
- (5) Drive plate
- (6) Driven plate
- (7) Pressure plate
- (8) Snap ring
- (9) Transfer piston seal
- (10) Return spring

- (11) Transfer clutch piston
- (12) Rear drive shaft
- (13) Ball bearing
- (14) Seal ring
- (15) Gasket
- (16) Transfer clutch pipe
- (17) Extension case
- (18) Transmission hanger
- (19) Oil seal
- (20) Dust cover

- (21) Test plug
- (22) O-ring
- (23) Clip

**Tightening torque: N·m (kgf·m, ft·lb)**

**T1: 13 (1.3, 9.4)**

**T2: 25 (2.5, 18.1)**

# GENERAL DESCRIPTION

Automatic Transmission

## 12. TRANSFER AND EXTENSION CASE WITH VTD

S510001A0512

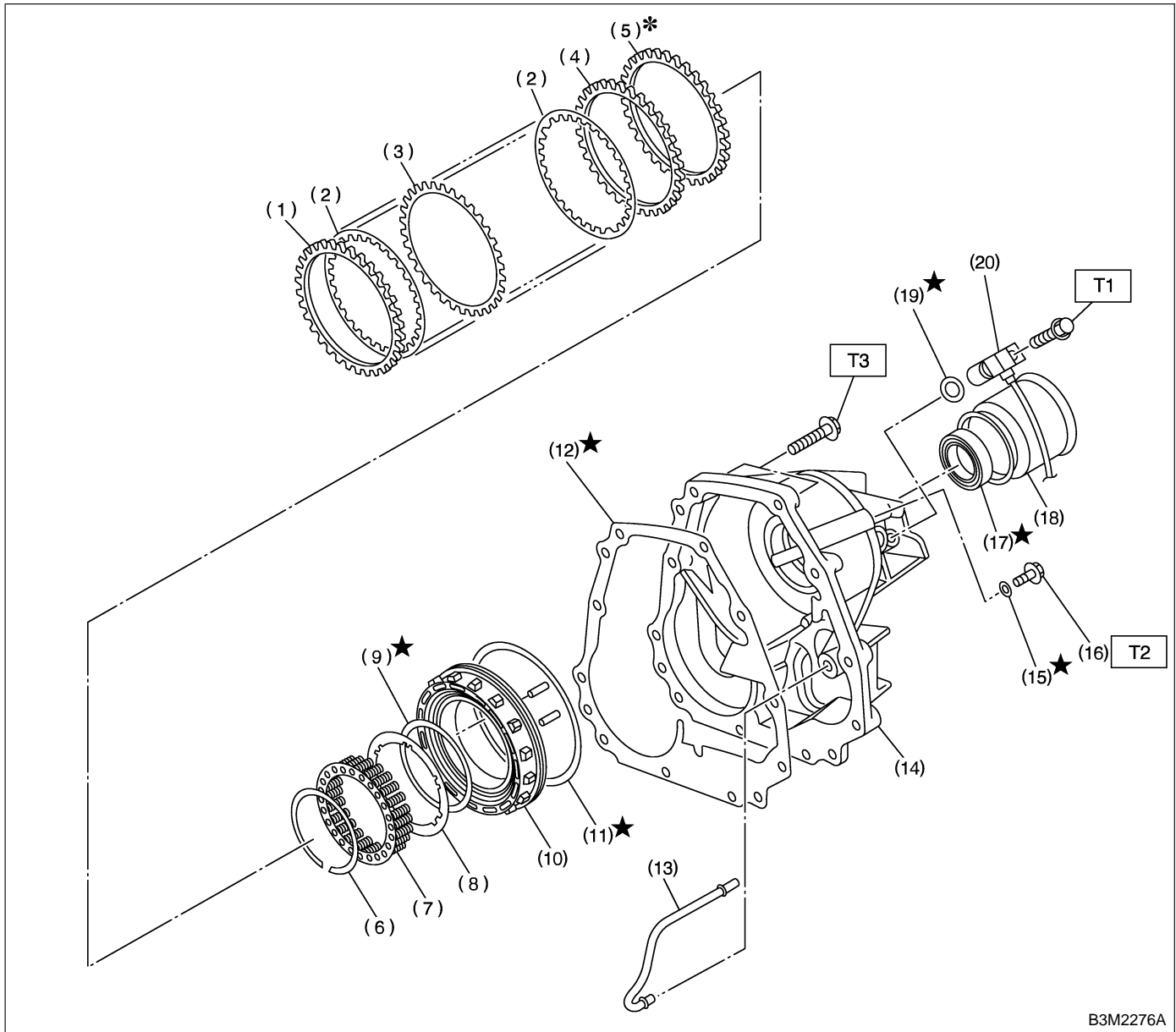

B3M2276A

- (1) Driven plate (Thicker)
- (2) Drive plate
- (3) Driven plate (Thinner)
- (4) Driven plate (Thicker)
- (5) Adjust plate
- (6) Snap ring
- (7) Spring retainer
- (8) Plate
- (9) Lathe cut seal ring

- (10) Multi-plate clutch (LSD) piston ASSY
- (11) Lathe cut seal ring
- (12) Gasket
- (13) Multi-plate clutch (LSD) pipe
- (14) Extension case
- (15) O-ring
- (16) Test plug
- (17) Oil seal

- (18) Dust cover
- (19) O-ring
- (20) Rear vehicle speed sensor

**Tightening torque: N·m (kgf·m, ft·lb)**

**T1: 7 (0.7, 5.1)**

**T2: 13 (1.3, 9.4)**

**T3: 25 (2.5, 18.1)**

**C: PRECAUTION** SS10001F59

When disassembling or assembling the automatic transmission, observe the following instructions.

**1) Workshop**

Provide a place that is clean and free from dust. Principally the conventional workshop is suitable except for a dusty place. In a workshop where grinding work, etc. which produces fine particles is done, make independent place divided by the vinyl curtain or the equivalent.

**2) Work table**

The size of 1 x 1.5 m (40 x 60 in) is large enough to work, and it is more desirable that its surface be covered with flat plate like iron plate which is not rusted too much.

**3) Cleaning of exterior**

(1) Clean the exterior surface of transmission with steam and/or kerosene prior to disassembly, however it should be noted that vinyl tape be placed on the air breather or oil level gauge to prevent infiltration of the steam into the transmission and also the cleaning job be done away from the place of disassembly and assembly.

(2) Partial cleaning will do, depending on the extent of disassembly (such as when disassembly is limited to some certain parts).

**4) Disassembly, assembly and cleaning**

(1) Disassemble and assemble the transmission while inspecting the parts in accordance with the Diagnostics.

(2) During job, do not use gloves. Do not clean the parts with rags: Use chamois or nylon cloth.

(3) Pay special attention to the air to be used for cleaning. Get the moisture and the dust rid of the air as much as possible. Be careful not to scratch or dent any part while checking for proper operation with an air gun.

(4) Complete the job from cleaning to completion of assembly as continuously and speedily as possible in order to avoid occurrence of secondary troubles caused by dust. When stopping the job unavoidably cover the parts with clean chamois or nylon cloth to keep them away from any dust.

(5) Use kerosene, white gasoline or the equivalent as washing fluid. Use always new fluid for cleaning the automatic transmission parts and never reuse. The used fluid is usable in disassemble and assemble work of engine and manual transmission.

(6) Although the cleaning should be done by dipping into the washing fluid or blowing of the pressurized washing fluid, the dipping is more desirable. (Do not rub with a brush.) Assemble the parts immediately after the cleaning without exposure to the air for a while. Besides in case

of washing rubber parts, perform the job quickly not to dip them into the washing fluid for long time.

(7) Apply the automatic transmission fluid (ATF) onto the parts immediately prior to assembly, and the specified tightening torque should be observed carefully.

(8) Use vaseline if it is necessary to hold parts in the position when assembling.

(9) Drain ATF and differential gear oil into a saucer so that the conditions of fluid and oil can be inspected.

(10) Do not support axle drive shaft, stator shaft, input shaft or various pipes when moving transmission from one place to another.

(11) Always discard old oil seals and O-ring, and install new ones.

(12) Be sure to replace parts which are damaged, worn, scratched, discolored, etc.



# GENERAL DESCRIPTION

Automatic Transmission

## D: PREPARATION TOOL S510001A17

### 1. SPECIAL TOOLS S510001A1701

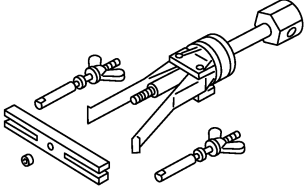
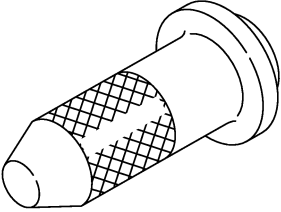
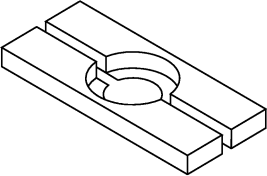
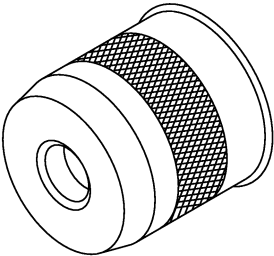
ILLUSTRATION	TOOL NUMBER	DESCRIPTION	REMARKS
 <p>B3M1977</p>	398527700	PULLER ASSY	<ul style="list-style-type: none"> <li>● Used for removing extension case roller bearing.</li> <li>● Used for removing extension oil seal.</li> <li>● Used for removing front differential side retainer bearing outer race.</li> </ul>
 <p>B3M1972</p>	498057300	INSTALLER	Used for installing extension oil seal.
 <p>B3M1998</p>	498077000	REMOVER	Used for removing differential taper roller bearing.
 <p>B3M1999</p>	499247400	INSTALLER	<ul style="list-style-type: none"> <li>● Used for installing transfer outer snap ring.</li> <li>● Used with GUIDE (499257300).</li> </ul>

# GENERAL DESCRIPTION

Automatic Transmission

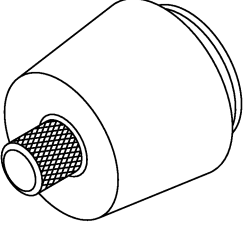
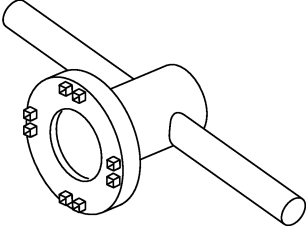
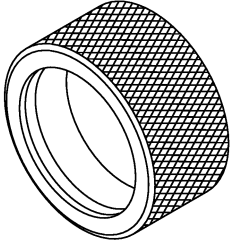
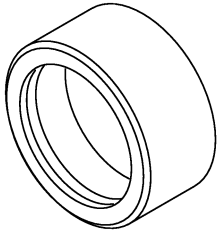
ILLUSTRATION	TOOL NUMBER	DESCRIPTION	REMARKS
 <p style="text-align: right;">B3M2000</p>	499257300	SNAP RING OUTER GUIDE	<ul style="list-style-type: none"> <li>● Used for installing transfer outer snap ring.</li> <li>● Used with INSTALLER (499247400).</li> </ul>
 <p style="text-align: right;">B3M1953</p>	499787000	WRENCH ASSY	Used for removing and installing differential side retainer.
 <p style="text-align: right;">B3M2001</p>	398437700	DRIFT	Used for installing converter case oil seal.
 <p style="text-align: right;">B3M1912</p>	398487700	INSTALLER	Used for installing taper roller bearing of front differential.

# GENERAL DESCRIPTION

Automatic Transmission

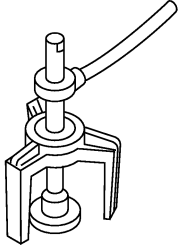
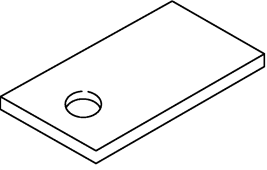
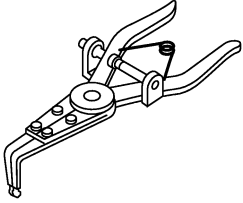
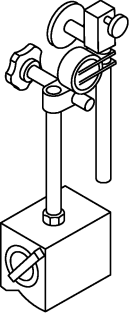
ILLUSTRATION	TOOL NUMBER	DESCRIPTION	REMARKS
 <p style="text-align: center;">B3M2002</p>	398673600	COMPRESSOR	Used for removing and installing clutch spring.
 <p style="text-align: center;">B3M1973</p>	498255400	PLATE	Used for measuring backlash of hypoid gear.
 <p style="text-align: center;">B3M2003</p>	399893600	PLIERS	Used for removing and installing clutch spring.
 <p style="text-align: center;">B3M1945</p>	498247001	MAGNET BASE	<ul style="list-style-type: none"> <li>● Used for measuring gear backlash.</li> <li>● Used with DIAL GAUGE (498247100).</li> </ul>

# GENERAL DESCRIPTION

Automatic Transmission

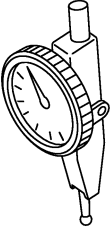
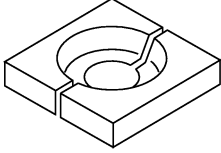
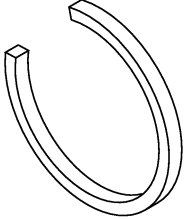
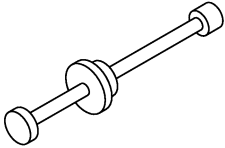
ILLUSTRATION	TOOL NUMBER	DESCRIPTION	REMARKS
 <p>B3M1946</p>	498247100	DIAL GAUGE	<ul style="list-style-type: none"> <li>• Used for measuring gear backlash.</li> <li>• Used with MAGNET BASE (498247001).</li> </ul>
 <p>B3M2004</p>	498517000	REPLACER	Used for removing front roller bearing.
 <p>B3M2005</p>	498627100	SEAT	Used for removing spring of transfer clutch piston.
 <p>B3M2006</p>	499095500	REMOVER	Used for removing axle shaft.

# GENERAL DESCRIPTION

Automatic Transmission

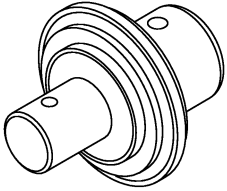
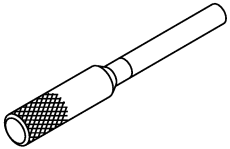
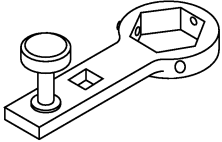
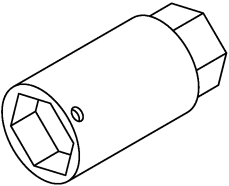
ILLUSTRATION	TOOL NUMBER	DESCRIPTION	REMARKS
 <p style="text-align: center;">B3M2007</p>	499247300	INSTALLER	<ul style="list-style-type: none"> <li>● Used for removing axle shaft.</li> <li>● Used with REMOVER (499095500).</li> </ul>
 <p style="text-align: center;">B3M2008</p>	499267300	STOPPER PIN	Used for installing inhibitor switch.
 <p style="text-align: center;">B3M2009</p>	499787700	WRENCH	Used for removing and installing drive pinion lock nut.
 <p style="text-align: center;">B3M2010</p>	499787500	ADAPTER	Used for removing and installing drive pinion lock nut.

# GENERAL DESCRIPTION

Automatic Transmission

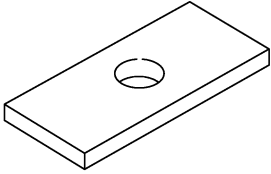
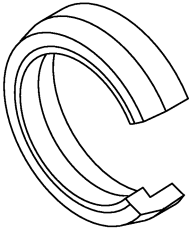
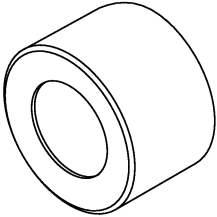
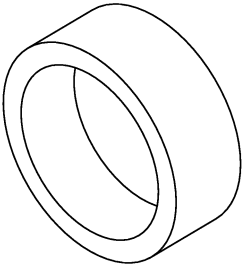
ILLUSTRATION	TOOL NUMBER	DESCRIPTION	REMARKS
 <p style="text-align: center;">B3M1978</p>	398643600	GAUGE	Used for measuring total end play, extension end play and drive pinion height.
 <p style="text-align: center;">B3M2011</p>	498627100	SEAT	Used for holding low clutch piston retainer spring when installing snap ring.
 <p style="text-align: center;">B3M2012</p>	499577000	GAUGE	<ul style="list-style-type: none"> <li>● Used for measuring the transmission case mating surface to the reduction gear end surface.</li> <li>● For without VTD.</li> </ul>
 <p style="text-align: center;">B2M3854</p>	398744300	GAUGE	<ul style="list-style-type: none"> <li>● Used for measuring the transmission case mating surface to the multi-plate clutch end surface.</li> <li>● For with VTD.</li> </ul>

# GENERAL DESCRIPTION

Automatic Transmission

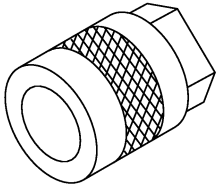
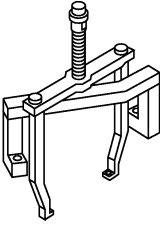
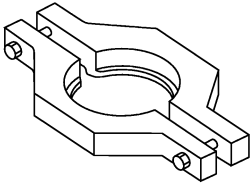
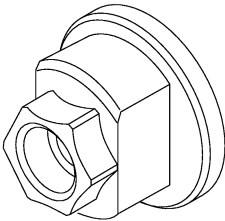
ILLUSTRATION	TOOL NUMBER	DESCRIPTION	REMARKS
 <p style="text-align: center;">B3M2013</p>	499737000	PULLER	Used for removing reduction driven gear assembly.
 <p style="text-align: center;">B3M2014</p>	499737100	PULLER SET	Used for removing reduction drive gear assembly.
 <p style="text-align: center;">B3M2015</p>	498077600	REMOVER	Used for removing ball bearing.
 <p style="text-align: center;">B3M2016</p>	498937110	HOLDER	Used for removing and installing drive pinion lock nut.

# GENERAL DESCRIPTION

Automatic Transmission

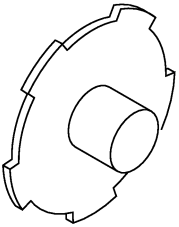
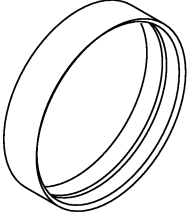
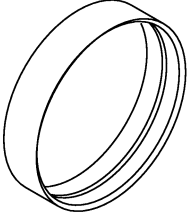
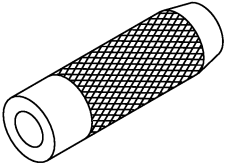
ILLUSTRATION	TOOL NUMBER	DESCRIPTION	REMARKS
 <p data-bbox="362 541 446 562">B3M2017</p>	498677100	COMPRESSOR	Used for installing 2-4 brake snap ring.
 <p data-bbox="362 928 446 949">B3M2018</p>	498437000	HIGH CLUTCH PISTON GUIDE	Used for installing high clutch piston.
 <p data-bbox="362 1314 446 1335">B3M2018</p>	498437100	LOW CLUTCH PISTON GUIDE	Used for installing low clutch piston.
 <p data-bbox="362 1701 446 1722">B3M2019</p>	899580100	INSTALLER	Used for press-fitting the ball bearing for transfer clutch.



# GENERAL DESCRIPTION

Automatic Transmission

## 2. GENERAL PURPOSE TOOLS SS10001A1702

TOOL NAME	REMARKS
Depth gauge	Used for measuring transmission end play.
Thickness gauge	Used for measuring clearances of clutch, brake and oil pump.
Micro meter	Used for measuring thickness of drive pinion.
Spring balance	Used for measuring starting torque of drive pinion.

## E: PROCEDURE SS10001E45

- In this section the procedures described under each index are all connected and stated in order. It will be the complete procedure for overhauling of the automatic transmission itself when you go through all steps in the process. Therefore, in this section, to conduct the particular procedure within the flow of a section, you need to go back and conduct the procedure described previously in order to do that particular procedure.