

7. Torque Converter Clutch Assembly S510210

A: REMOVAL S510210A18

1) Extract the torque converter clutch assembly.

NOTE:

- Extract the torque converter clutch horizontally. Be careful not to scratch the bushing inside the oil pump shaft.
- Note that oil pump shaft also comes out.

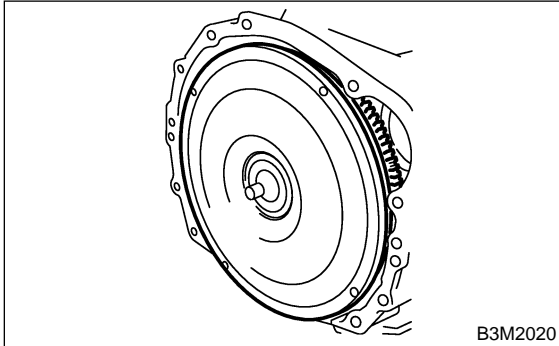

2) Remove the input shaft.

NOTE:

When the torque converter clutch assembly is removed, the input shaft will come out.

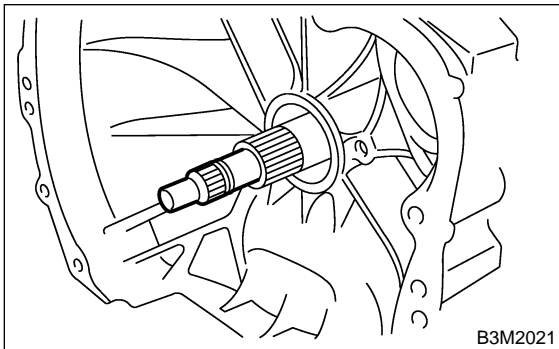

3) Extract the oil pump shaft from torque converter clutch.

4) Remove the clip from torque converter clutch.

B: INSTALLATION S510210A11

- 1) Install the clip to torque converter clutch.
- 2) Install the oil pump shaft to the torque converter clutch.

NOTE:

Make sure the clip fits securely in its groove.

3) Insert the input shaft while turning lightly by hand.

NOTE:

Be careful not to damage the bushing.

Normal protrusion A:

50 — 55 mm (1.97 — 2.17 in)

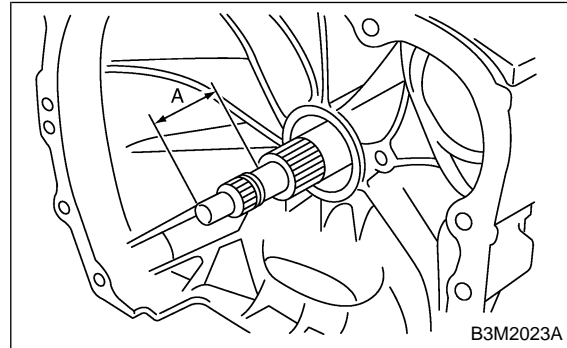

4) Holding the torque converter clutch assembly by hand, carefully install it to the torque converter clutch case. Be careful not to damage the bushing. Also avoid undue contact between the oil pump shaft bushing and stator shaft portion of the oil pump cover.

5) Rotate the shaft lightly by hand to engage the splines securely.

Dimension A:

1.6 L and 2.0 L models; -1.3 to -1.1 mm (-0.051 to -0.043 in)

2.0 L TURBO, 2.5 L and 3.0 L models; 2.7 — 2.9 mm (0.106 — 0.114 in)

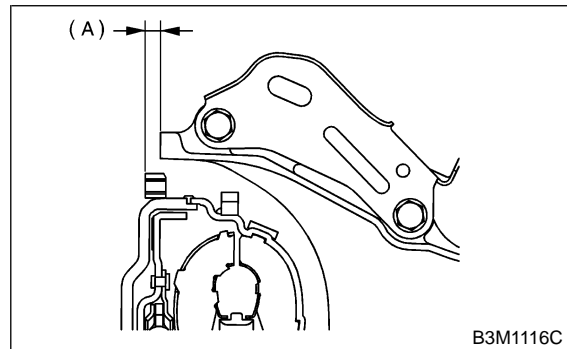

(A) Dimension A

C: INSPECTION S510210A10

Make sure the ring gear is not damaged and that the protrusion on the edge of the torque converter clutch is not deformed or otherwise damaged.