

## 18. Oil Pump S510070

### A: REMOVAL S510070A18

- 1) Extract the torque converter clutch assembly. <Ref. to AT-35, REMOVAL, Torque Converter Clutch Assembly.>
- 2) Remove the input shaft.

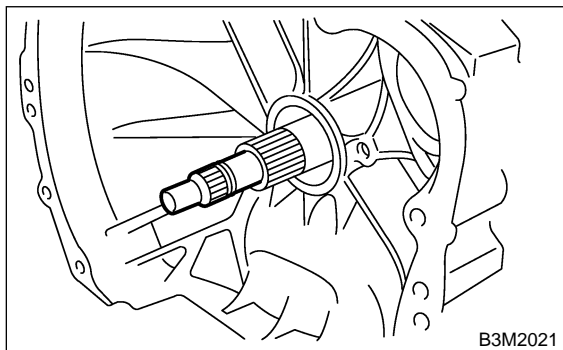

- 3) Disconnect transmission harness connector from stay.

**NOTE:**

Lift-up lever behind the connector and disconnect it from stay.

- 4) Disconnect inhibitor switch connector from stay.
- 5) Disconnect the air breather hose. <Ref. to AT-28, REMOVAL, Air Breather Hose.>
- 6) Remove the oil charger pipe. <Ref. to AT-29, REMOVAL, Oil Charger Pipe.>
- 7) Remove the oil cooler inlet and outlet pipes. <Ref. to AT-30, REMOVAL, Oil Cooler Pipes.>
- 8) Separation of torque converter clutch case and transmission case sections <Ref. to AT-58, REMOVAL, Torque Converter Clutch Case.>
- 9) Separate transmission case and extension case sections. <Ref. to AT-36, REMOVAL, Extension Case.>
- 10) Remove the reduction driven gear. Without VTD <Ref. to AT-48, WITHOUT VTD, REMOVE, Reduction Driven Gear.> With VTD <Ref. to AT-48, WITH VTD, REMOVE, Reduction Driven Gear.>
- 11) Loosen the taper roller bearing mounting bolts.

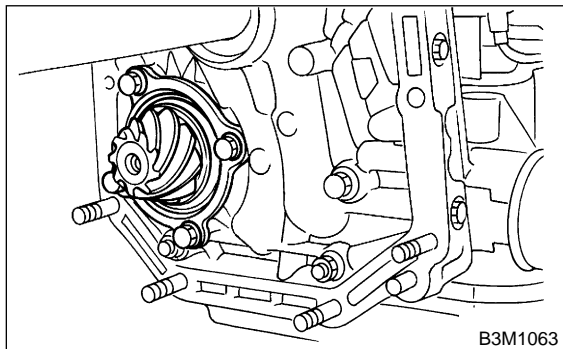

- 12) Place two wooden blocks on the workbench, and stand the transmission case with its rear end facing down.

**CAUTION:**

- Be careful not to scratch the rear mating surface of the transmission case.
- Note that the parking rod and drive pinion protrude from the mating surface.

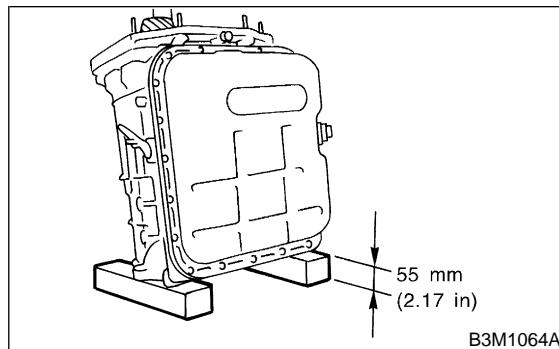

- 13) Remove the oil pump housing and adjusting thrust washer.

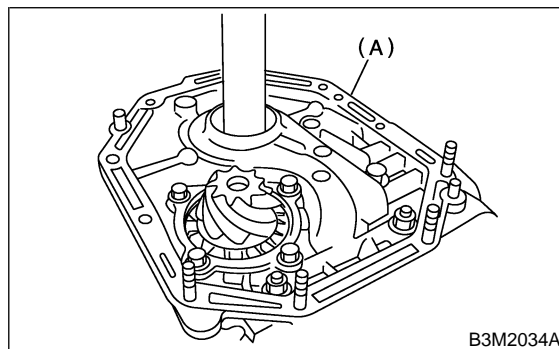

(A) Oil pump housing

- 14) Remove the oil seal retainer. Also remove the O-ring and oil seal (air breather).

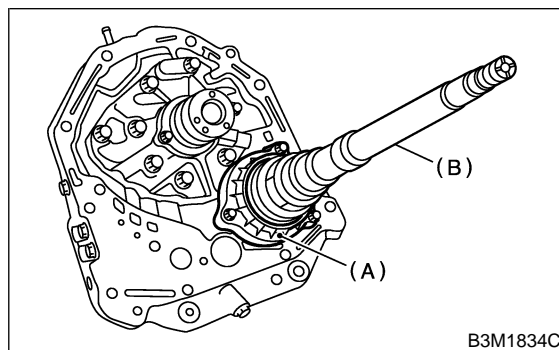

(A) Oil seal retainer  
(B) Drive pinion shaft

- 15) Remove O-rings from oil pump housing.

**NOTE:**

Do not re-use O-ring. Prepare a new one.

- 16) Remove the drive pinion assembly.

## B: INSTALLATION S510070A11

1) Assemble the drive pinion assembly to the oil pump housing.

**NOTE:**

- Be careful not to bend the shims.
- Be careful not to force the pinion against the housing bore.

2) Tighten four bolts to secure the roller bearing.

**Tightening torque:**

**40 N·m (4.1 kgf-m, 30 ft-lb)**

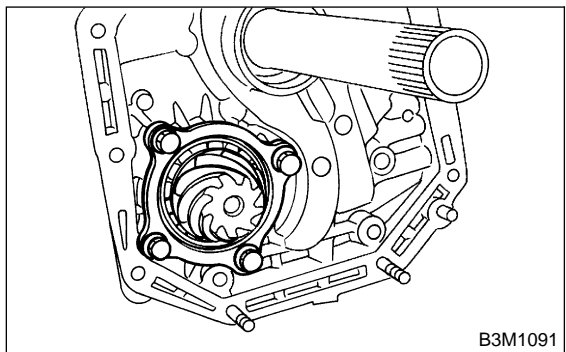

3) Install two new oil seals to the oil seal retainer with ST.

**NOTE:**

Pay attention to the orientation of the oil seals.

ST 499247300 INSTALLER

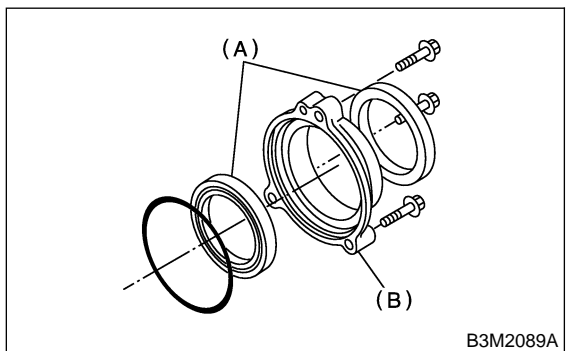

- (A) Oil seal
- (B) Oil seal retainer

4) Attach the new O-ring to the oil seal retainer with vaseline. Install the seal to the oil pump housing bore.

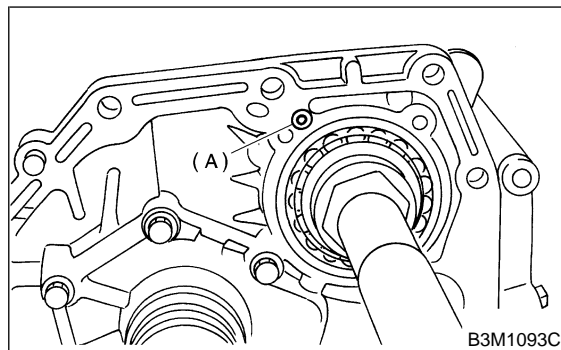

- (A) O-ring

5) Install the oil seal retainer taking care not to damage the oil seal lips. Then secure with three bolts.

**NOTE:**

Make sure the O-ring is fitted correctly in position.

**Tightening torque:**

**7 N·m (0.7 kgf-m, 5.1 ft-lb)**

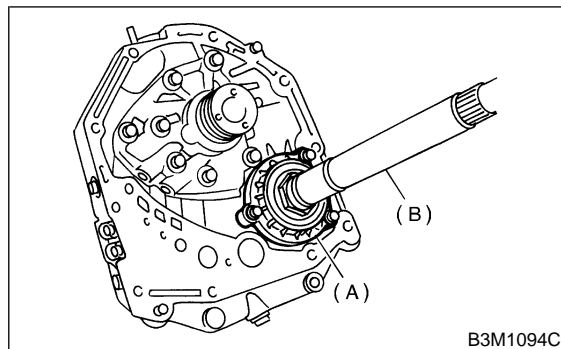

- (A) Oil seal retainer
- (B) Drive pinion shaft

6) Secure the housing with two nuts and the bolt.

**Tightening torque:**

**42 N·m (4.3 kgf-m, 31 ft-lb)**

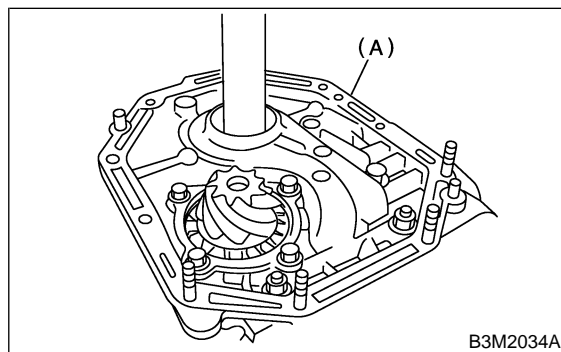

- (A) Oil pump housing

# OIL PUMP

## Automatic Transmission

7) Install the torque converter clutch case assembly to the transmission case assembly. <Ref. to AT-35, INSTALLATION, Torque Converter Clutch Assembly.>

8) Install reduction driven gear. <Ref. to AT-48, WITHOUT VTD, INSTALLATION, Reduction Driven Gear.> <Ref. to AT-49, WITH VTD, INSTALLATION, Reduction Driven Gear.>

9) Combine the extension case with the transmission case, and install vehicle speed sensor 1 (rear). <Ref. to AT-36, INSTALLATION, Extension Case.>

10) Insert inhibitor switch and transmission connector into stay.

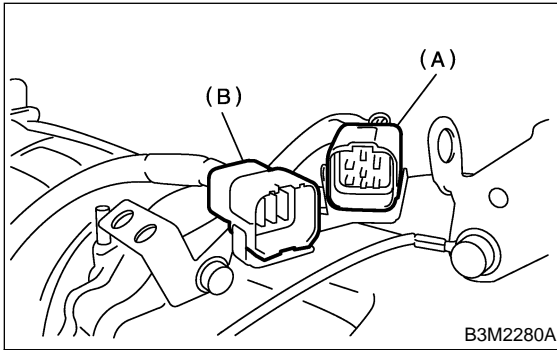

- (A) Transmission harness
- (B) Inhibitor switch harness

11) Install air breather hose. <Ref. to AT-28, INSTALLATION, Air Breather Hose.>

12) Install the oil cooler pipe. <Ref. to AT-30, INSTALLATION, Oil Cooler Pipe.>

13) Install the oil charger pipe with O-ring. <Ref. to AT-29, INSTALLATION, Oil Charger Pipes.>

14) Insert the input shaft while turning lightly by hand.

### NOTE:

Be careful not to damage the bushing.

### Normal protrusion A:

50 — 55 mm (1.97 — 2.17 in)

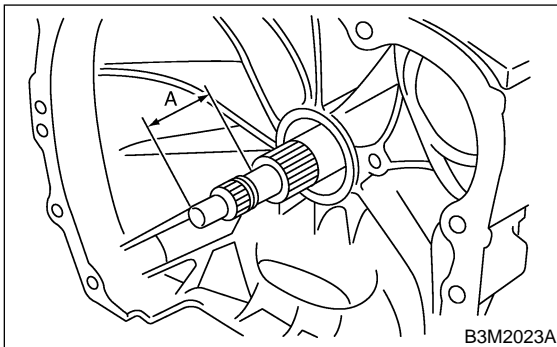

15) Install the torque converter clutch assembly. <Ref. to AT-35, INSTALLATION, Torque Converter Clutch Assembly.>

## C: DISASSEMBLY S510070A06

1) Remove four seal rings.

### NOTE:

Do not re-use O-ring. Prepare a new one.

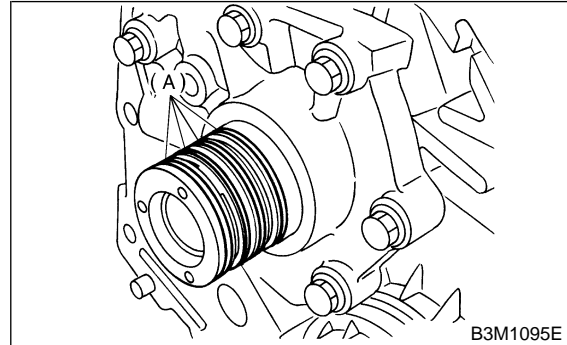

- (A) Seal rings

2) Remove the oil pump cover.

### NOTE:

Lightly tap the end of the stator shaft to remove the cover.

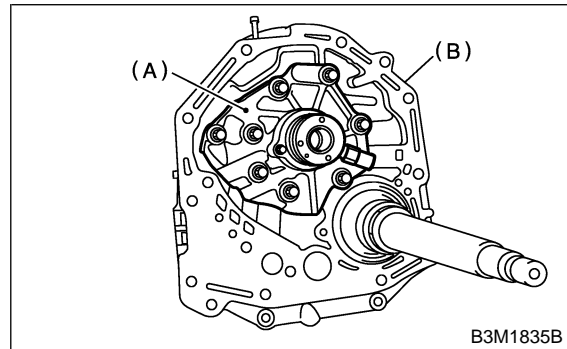

- (A) Oil pump cover
- (B) Oil pump housing

3) Remove the inner and outer rotor.

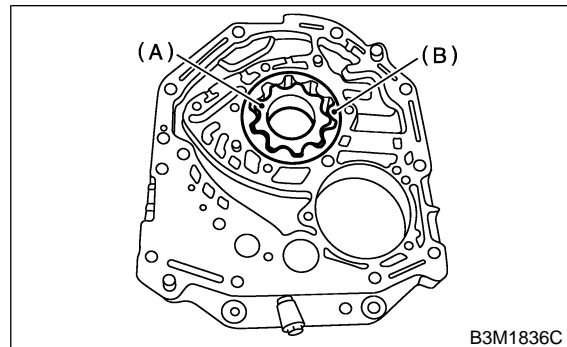

- (A) Inner rotor
- (B) Outer rotor

## D: ASSEMBLY S510070A02

1) Install oil pump rotor assembly to oil pump housing.

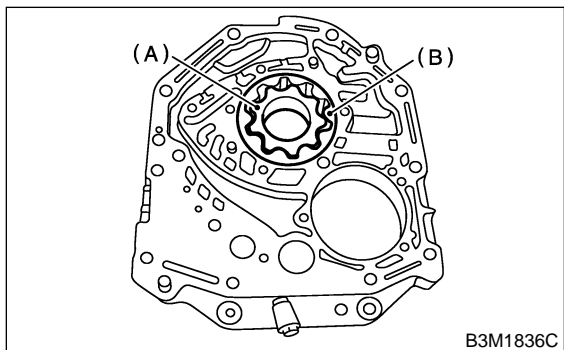

- (A) Inner rotor
- (B) Outer rotor

2) Install the oil pump cover.

### Tightening torque:

**25 N·m (2.5 kgf-m, 18.1 ft-lb)**

### NOTE:

- Align both pivots with the pivot holes of the cover, and install the cover being careful not to apply undue force to the pivots.
- After assembling, turn the oil pump shaft to check for smooth rotation of the rotor.

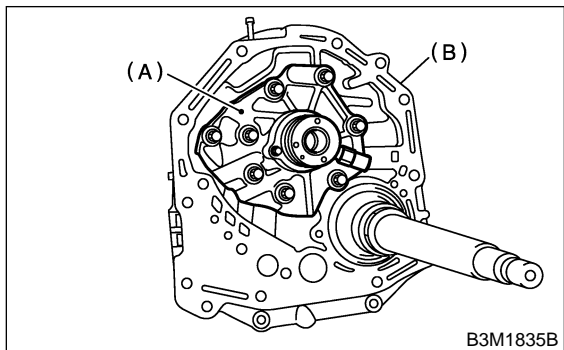

- (A) Oil pump cover
- (B) Oil pump housing

3) Install the oil seal retainer and new seal rings. After adjusting the drive pinion backlash and tooth contact. <Ref. to AT-66, ADJUSTMENT, Oil Pump.>

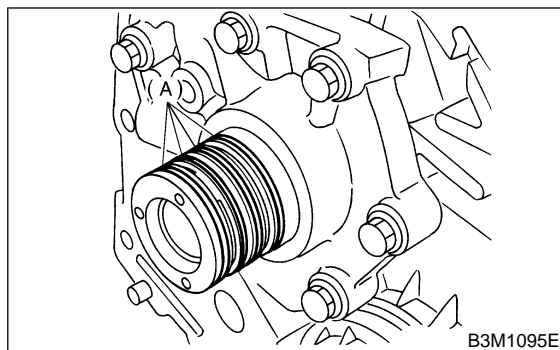

- (A) Seal rings

## E: INSPECTION S510070A10

- 1) Check seal ring and O-ring oil seal for breaks or damage.
- 2) Check other parts for dents or abnormalities.
- 3) Selection of oil pump rotor assembly
  - (1) Tip clearance  
Install inner rotor and outer rotor to oil pump. With rotor gears facing each other, measure crest-to-crest clearance.

### Tip clearance:

**0.02 — 0.15 mm (0.0008 — 0.0059 in)**

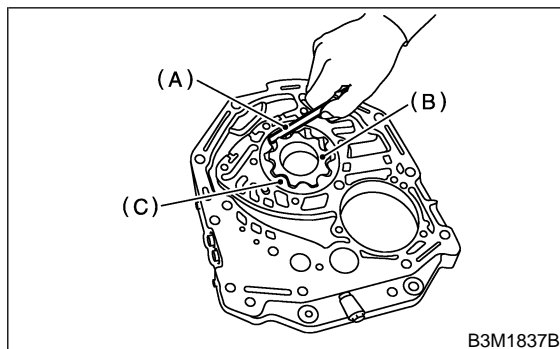

- (A) Thickness gauge
- (B) Inner rotor
- (C) Outer rotor

# OIL PUMP

Automatic Transmission

## (2) Side clearance

Set a depth gauge to oil pump housing, then measure oil pump housing-to-rotor clearances.

### Side clearance:

0.02 — 0.04 mm (0.0008 — 0.0016 in)

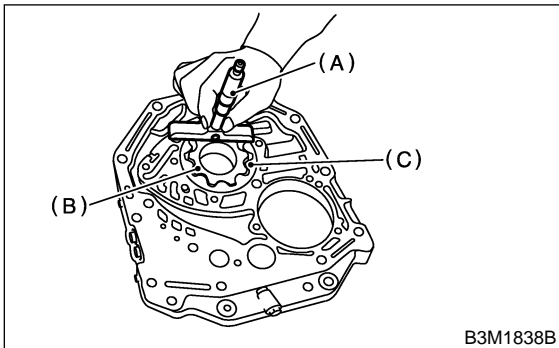

- (A) Depth gauge
- (B) Inner rotor
- (C) Outer rotor

(3) If depth and/or side clearances are outside specifications, replace rotor assembly.

Oil pump rotor assembly	
Part No.	Thickness mm (in)
15008AA060	11.37 — 11.38 (0.4476 — 0.4480)
15008AA070	11.38 — 11.39 (0.4480 — 0.4484)
15008AA080	11.39 — 11.40 (0.4484 — 0.4488)

● Measure the total end play and adjust to within specifications. <Ref. to AT-66, ADJUSTMENT, Oil Pump.>

## F: ADJUSTMENT SS10070A01

1) Using ST, measure the distance from the transmission case mating surface to the recessed portion of the high clutch drum "L".

ST 398643600 GAUGE

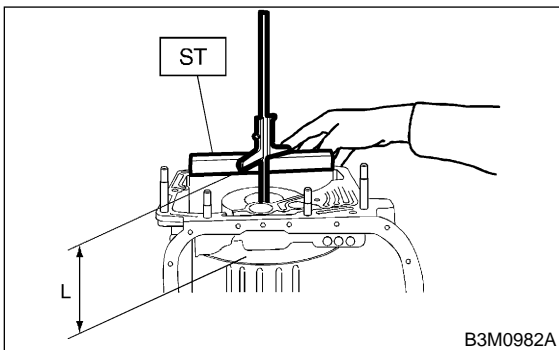

2) Using ST, measure the distance from the oil pump housing mating surface to the top surface of the oil pump cover with thrust needle bearing.

ST 398643600 GAUGE

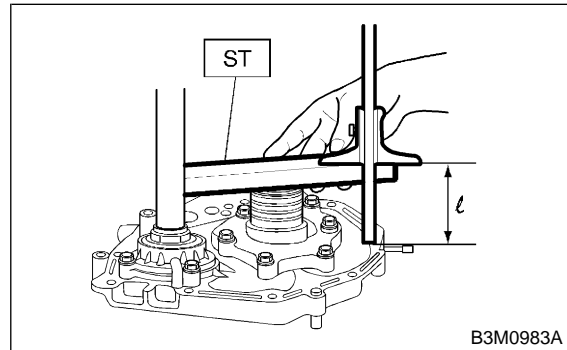

## 3) Calculation of total end play

Select suitable bearing race from among those listed in this table so that clearance C is in the 0.25 to 0.55 mm (0.0098 to 0.0217 in) range.

$$C = (L + G) - \ell$$

C	Clearance between concave portion of high clutch and end of clutch drum support
L	Length from case mating surface to concave portion of high clutch
G	Gasket thickness [0.28 mm (0.0110 in)]
$\ell$	Height from housing mating surface to upper surface of clutch drum support

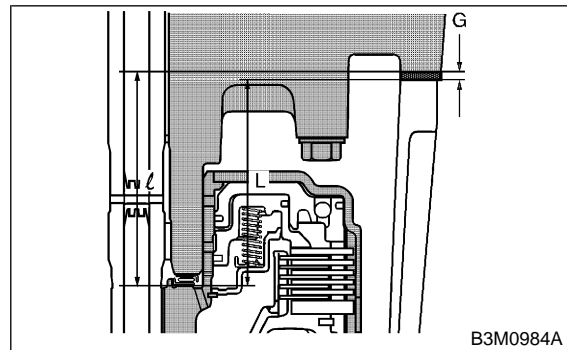

Thrust needle bearing	
Part No.	Thickness mm (in)
806528050	4.1 (0.161)
806528060	4.3 (0.169)
806528070	4.5 (0.177)
806528080	4.7 (0.185)
806528090	4.9 (0.193)
806528100	5.1 (0.201)

4) After completing end play adjustment, insert the bearing race in the recess of the high clutch. Attach the thrust needle bearing to the oil pump cover with vaseline.

5) After correctly installing the new gasket to the case mating surface, carefully install the oil pump housing assembly. Be careful to avoid hitting the drive pinion against the inside of the case.

**NOTE:**

Be careful not to damage the seal ring.

6) Install both parts with dowel pins aligned. Make sure no clearance exists at the mating surface.

**NOTE:**

Any clearance suggests a damaged seal ring.