

22. High Clutch and Reverse Clutch

S510213

A: REMOVAL

S510213A18

- 1) Extract the torque converter clutch assembly.
<Ref. to AT-35, REMOVAL, Torque Converter Clutch Assembly.>
- 2) Remove the input shaft.

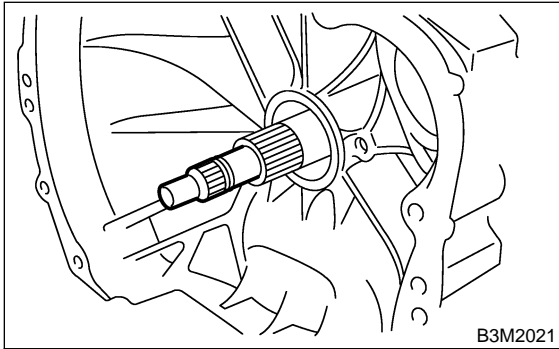

B3M2021

- 3) Disconnect transmission harness connector from stay.

NOTE:

Lift-up lever behind the connector and disconnect it from stay.

- 4) Disconnect inhibitor switch connector from stay.
- 5) Disconnect the air breather hose.
- 6) Remove the oil charger pipe. <Ref. to AT-29, REMOVAL, Oil Charger Pipe.>
- 7) Remove the oil cooler inlet and outlet pipes. <Ref. to AT-30, REMOVAL, Oil Cooler Pipes.>
- 8) Separation of torque converter clutch case and transmission case. <Ref. to AT-58, REMOVAL, Torque Converter Clutch Case.>
- 9) Remove the oil pump housing. <Ref. to AT-62, REMOVAL, Oil Pump.>
- 10) Take out the high clutch, thrust needle bearing and reverse clutch assembly.

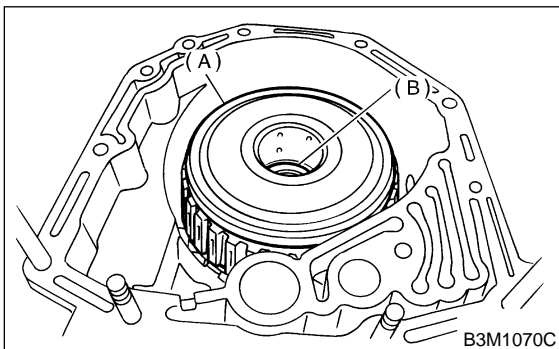

B3M1070C

- (A) High clutch and reverse clutch assembly
- (B) Thrust needle bearing

- 11) Take out the high clutch hub and the thrust bearing.

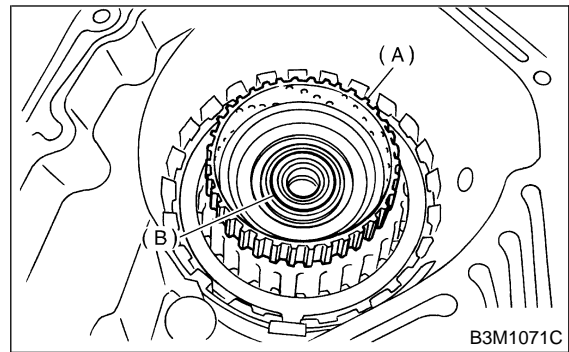

B3M1071C

- (A) High clutch hub
- (B) Thrust needle bearing

HIGH CLUTCH AND REVERSE CLUTCH

Automatic Transmission

B: INSTALLATION S510213A11

1) Install the high clutch hub and thrust needle bearing.

Attach the thrust needle bearing to the hub with vaseline and install the hub by correctly engaging the splines of the front planetary carrier.

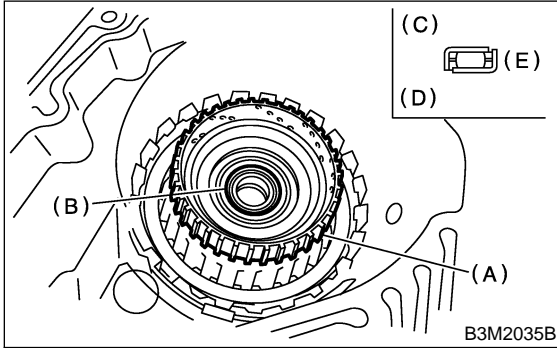

- (A) High clutch hub
- (B) Thrust needle bearing
- (C) Up side
- (D) Down side
- (E) Outside

2) Install the high clutch assembly.

NOTE:

Correctly engage the high clutch hub and clutch splines.

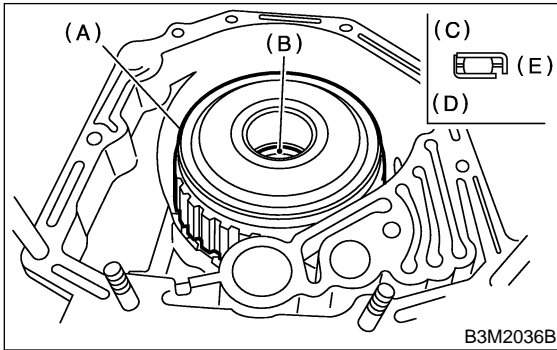

- (A) High clutch and reverse clutch assembly
- (B) Thrust needle bearing
- (C) Up side
- (D) Down side
- (E) Outside

3) Adjust total end play. <Ref. to AT-66, ADJUSTMENT, Oil Pump.>

4) Install the oil pump housing assembly.

5) Install the torque converter clutch case assembly to the transmission case assembly. <Ref. to AT-59, INSTALLATION, Torque Converter Clutch Case.>

6) Insert inhibitor switch and transmission connector into stay.

7) Install air breather hose. <Ref. to AT-28, INSTALLATION, Air Breather Hose.>

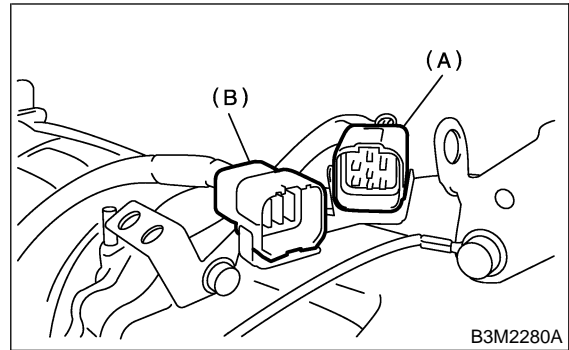

- (A) Transmission harness
- (B) Inhibitor switch harness

8) Install oil cooler pipes. <Ref. to AT-30, INSTALLATION, Oil Cooler Pipes.>

9) Install the oil charger pipe with O-ring. <Ref. to AT-29, INSTALLATION, Oil Charger Pipe.>

10) Insert the input shaft while turning lightly by hand.

CAUTION:

Be careful not to damage the bushing.

Normal protrusion A:

50 — 55 mm (1.97 — 2.17 in)

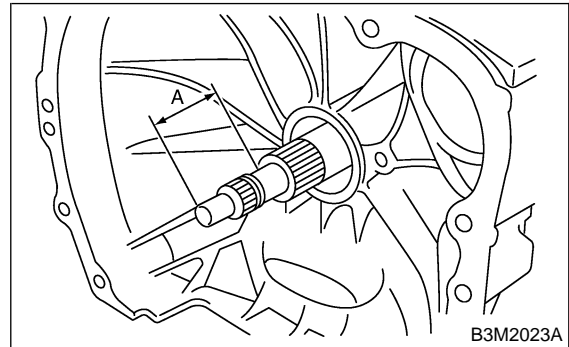

11) Install the torque converter clutch assembly. <Ref. to AT-35, INSTALLATION, Torque Converter Clutch Assembly.>

C: DISASSEMBLY S510213A06

1) Remove the snap ring, and take out the retaining plate, drive plates, driven plates.

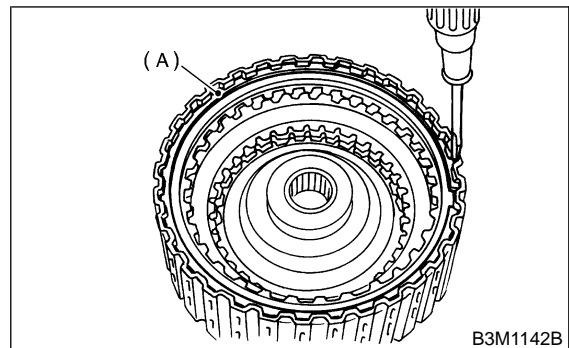

- (A) Snap ring

HIGH CLUTCH AND REVERSE CLUTCH

Automatic Transmission

2) Remove snap ring, and take out the retaining plate, drive plates and driven plates.

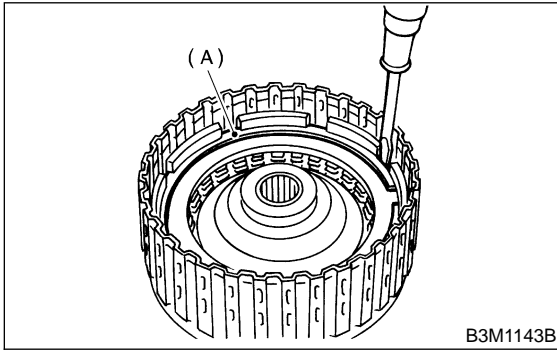

(A) Snap ring

3) Using ST1 and ST2, remove snap ring.
ST1 398673600 COMPRESSOR
ST2 498627100 SEAT

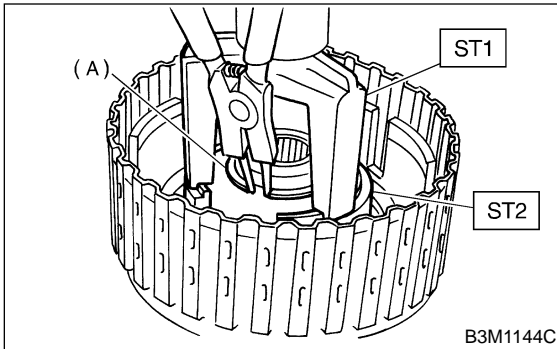

(A) Snap ring

4) Take out clutch cover, spring retainer, high clutch piston and reverse clutch piston.

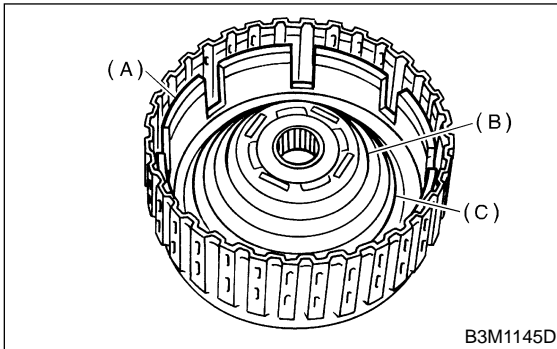

(A) Reverse clutch piston
(B) Cover
(C) Return spring

5) Remove seal rings and lip seal from high clutch piston and reverse clutch piston.

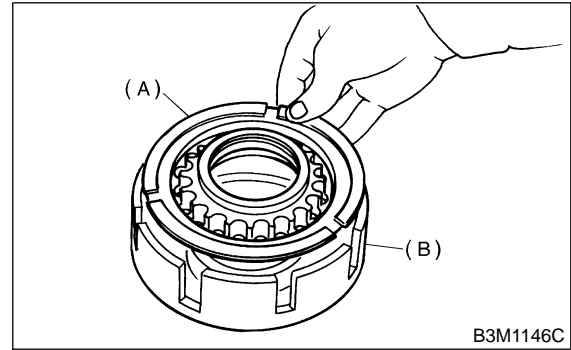

(A) High clutch piston
(B) Reverse clutch piston

D: ASSEMBLY S510213A02

1) Install seal rings and lip seal to high clutch piston and reverse clutch piston.

2) Install high clutch piston to reverse clutch piston.

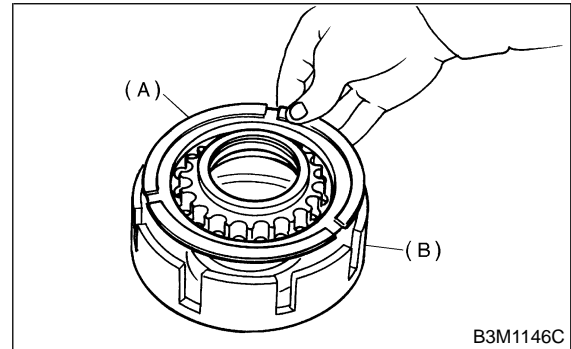

(A) High clutch piston
(B) Reverse clutch piston

3) Install reverse clutch to high clutch drum.

NOTE:

Align the groove on the reverse clutch piston with the groove on the high clutch drum during installation.

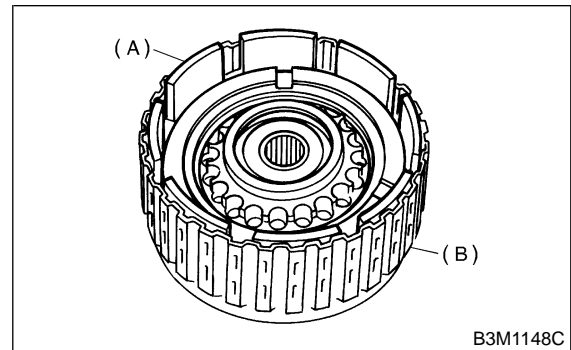

(A) Reverse clutch piston
(B) High clutch drum

HIGH CLUTCH AND REVERSE CLUTCH

Automatic Transmission

4) Install spring retainer to high clutch piston.

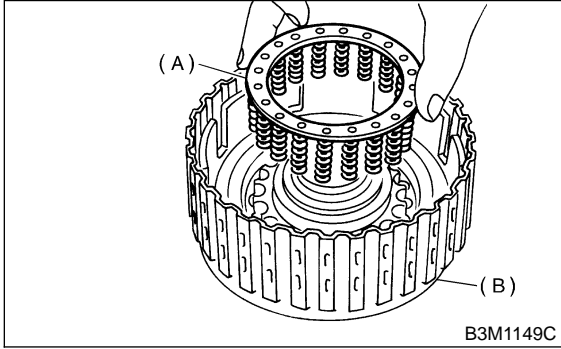

- (A) Return spring
- (B) High clutch drum

5) Install ST to high clutch piston.
ST 498437000 HIGH CLUTCH PISTON GAUGE

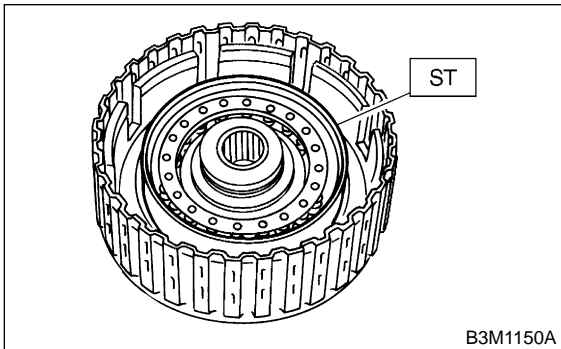

6) Install cover to high clutch piston.

NOTE:

Be careful not to fold over the high clutch piston seal during installation.

7) Using ST1 and ST2, install snap ring.

NOTE:

After installing snap ring, remove STs.

- ST1 398673600 COMPRESSOR
- ST2 498627100 SEAT
- ST3 498437000 HIGH CLUTCH PISTON GAUGE

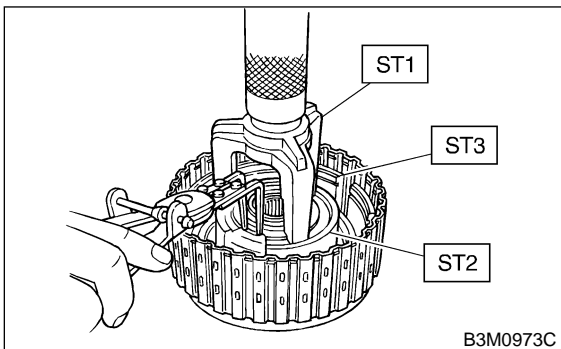

8) Install driven plate, drive plate and retaining plate to high clutch drum.

NOTE:

Install thicker driven plate on the piston side.

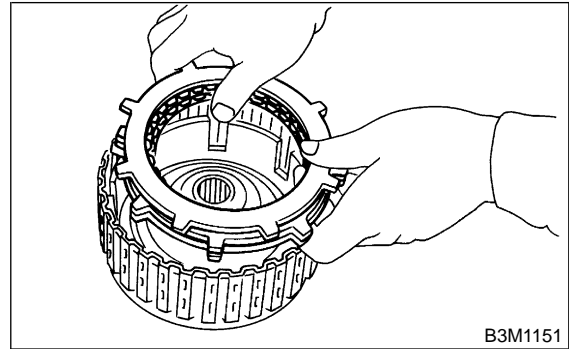

9) Install snap ring to high clutch drum.

10) Apply compressed air intermittently to check for operation.

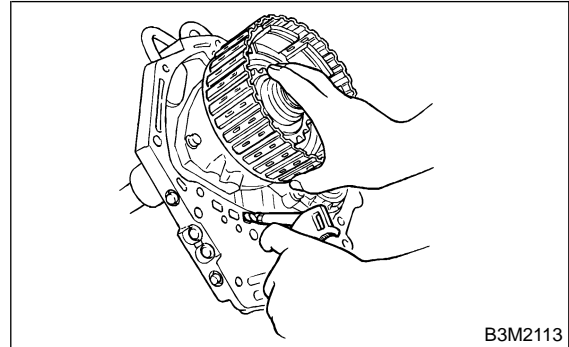

11) Measure the clearance between the retaining plate and snap ring. <Ref. to AT-91, INSPECTION, High Clutch and Reverse Clutch.>

12) Install driven plate, drive plate, retaining plate and snap ring.

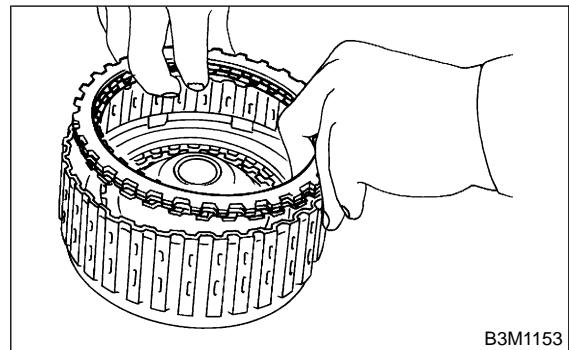

HIGH CLUTCH AND REVERSE CLUTCH

Automatic Transmission

13) Apply compressed air intermittently to check for operation.

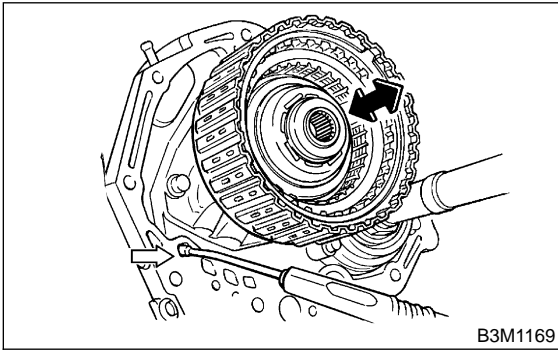

14) Measure the clearance between the retaining plate and snap ring. <Ref. to AT-90, INSPECTION, High Clutch and Reverse Clutch.>

E: INSPECTION S510213A10

- Drive plate facing for wear and damage
- Snap ring for wear, return spring for setting and breakage, and snap ring retainer for deformation
- Lip seal and lathe cut ring for damage
- Piston and drum check ball for operation
- Adjust total end play. <Ref. to AT-66, ADJUSTMENT, Oil Pump.>

1) Inspect clearance between the retaining plate and snap ring. (High clutch)

NOTE:

Do not press down retaining plate during clearance measurements.

Standard value:

0.8 — 1.1 mm (0.031 — 0.043 in)

Allowable limit:

1.5 mm (0.059 in)

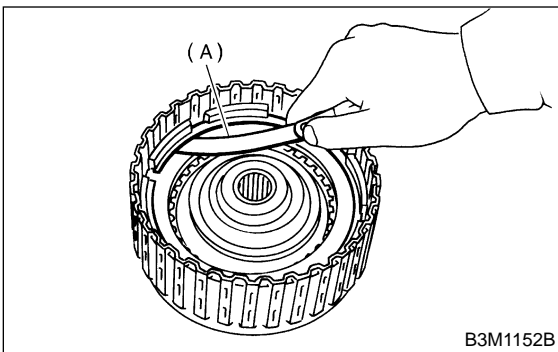

(A) Thickness gauge

If specified tolerance limits are exceeded, select a suitable high clutch retaining plate.

High clutch retaining plate	
Part No.	Thickness mm (in)
31567AA710	4.7 (0.185)
31567AA720	4.8 (0.189)
31567AA730	4.9 (0.193)
31567AA740	5.0 (0.197)
31567AA670	5.1 (0.201)
31567AA680	5.2 (0.205)
31567AA690	5.3 (0.209)
31567AA700	5.4 (0.213)

2) Inspect clearance between retaining plate and snap ring. (Reverse clutch)

NOTE:

Do not press down retaining plate during clearance measurements.

Standard value:

0.5 — 0.8 mm (0.020 — 0.031 in)

Allowable limit:

1.2 mm (0.047 in)

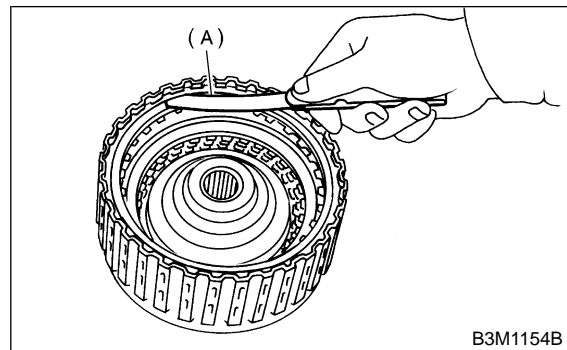

(A) Thickness gauge

If specified tolerance limits are exceeded, select a suitable high clutch retaining plate.

Reverse clutch retaining plates	
Part No.	Thickness mm (in)
31567AA910	4.0 (0.157)
31567AA920	4.2 (0.165)
31567AA930	4.4 (0.173)
31567AA940	4.6 (0.181)
31567AA950	4.8 (0.189)
31567AA960	5.0 (0.197)
31567AA970	5.2 (0.205)
31567AA980	5.4 (0.213)