

## 26. Low and Reverse Brake S510594

### A: REMOVAL S510594A18

- 1) Extract the torque converter clutch assembly. <Ref. to AT-35, REMOVAL, Torque Converter Clutch Assembly.>
- 2) Remove the input shaft.
- 3) Disconnect the air breather hose. <Ref. to AT-28, REMOVAL, Air Breather Hose.>
- 4) Disconnect transmission harness connector from stay.

**NOTE:**

Lift-up lever behind the connector and disconnect it from stay.

- 5) Disconnect inhibitor switch connector from stay.
- 6) Remove the oil charger pipe. <Ref. to AT-29, REMOVAL, Oil Charger Pipe.>
- 7) Remove the oil cooler inlet and outlet pipes. <Ref. to AT-30, REMOVAL, Oil Cooler Pipes.>
- 8) Separation of torque converter clutch case and transmission case. <Ref. to AT-58, REMOVAL, Torque Converter Clutch Case.>
- 9) Separate transmission case and extension case sections. <Ref. to AT-36, REMOVAL, Extension Case.>
- 10) Remove the reduction driven gear. WITHOUT VTD <Ref. to AT-48, WITHOUT VTD, REMOVAL, Reduction Driven Gear.> WITH VTD <Ref. to AT-48, WITH VTD, REMOVAL, Reduction Driven Gear.>
- 11) Remove the reduction drive gear. <Ref. to AT-51, REMOVAL, Reduction Drive Gear.>
- 12) Remove the oil pump housing. <Ref. to AT-62, REMOVAL, Oil Pump.>
- 13) Remove control valve assembly. <Ref. to AT-81, REMOVAL, Control Valve Body Assembly.>
- 14) Take out the high clutch and reverse clutch assembly. <Ref. to AT-87, REMOVAL, High Clutch and Reverse Clutch.>
- 15) Take out the thrust needle bearing, planetary gear assembly. <Ref. to AT-92, REMOVAL, Planetary Gear and Low Clutch.>
- 16) Take out 2-4 brake return spring, piston and piston retainer. <Ref. to AT-100, REMOVAL, 2-4 Brake.>
- 17) Remove one-way clutch inner race. <Ref. to AT-104, REMOVAL, One-way Clutch.>

- 18) Take out the low & reverse piston by applying compressed air.

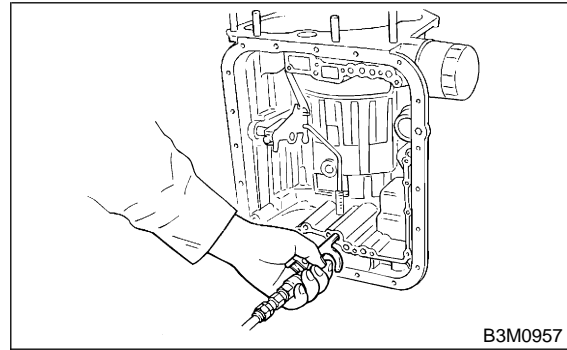

- 19) Take out the spring retainer, return spring and low & reverse piston.

### B: INSTALLATION S510594A11

- 1) Install the low and reverse piston.

**CAUTION:**

- Be careful not to tilt the piston when installing.
- Be careful not to damage the lip seal.

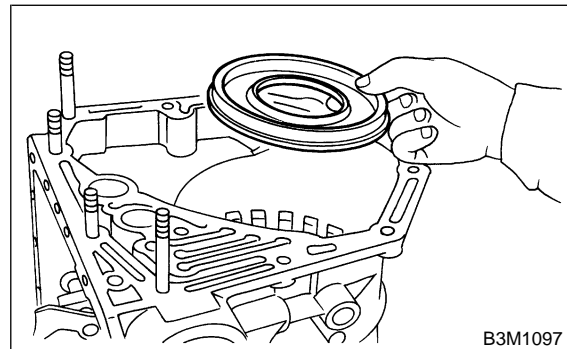

- 2) Install return spring.

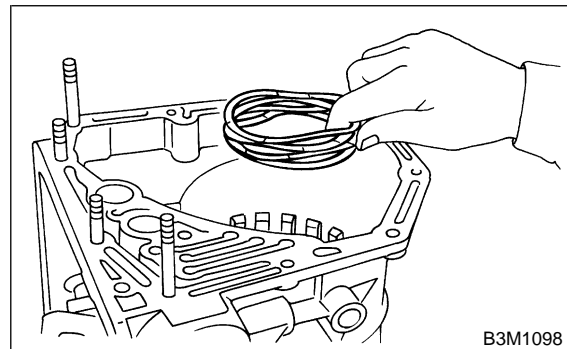

3) Install spring retainer.

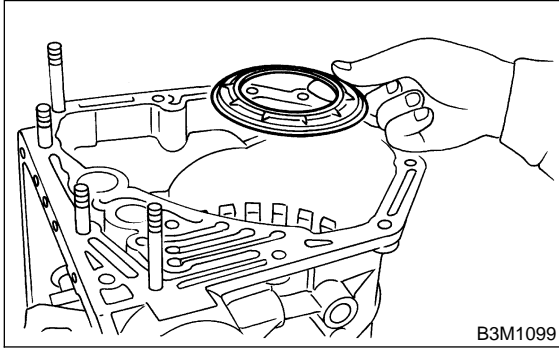

4) Install the one-way clutch inner race. <Ref. to AT-105, INSTALLATION, One-way Clutch.>

5) Install thrust needle bearing.

**NOTE:**

Place transmission case with the front facing up.

6) Installation of the low & reverse brake:  
Install dish plate, driven plates, drive plates, and a retaining plate, and secure with a snap ring.

**NOTE:**

Pay attention to the orientation of the dish plate.

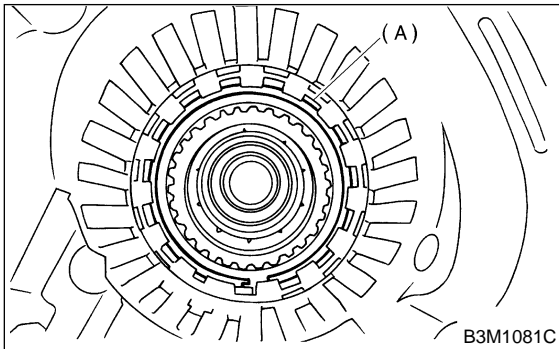

(A) Snap ring

7) Apply compressed air intermittently to check for operation.

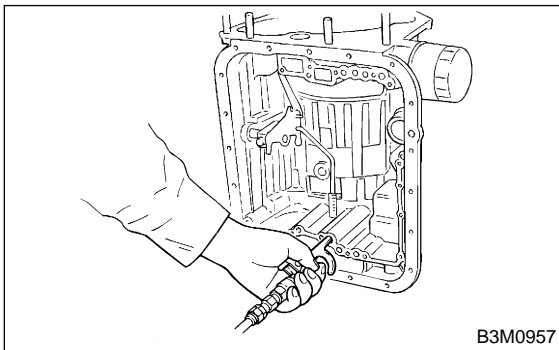

8) Check the clearance and select retaining plate. <Ref. to AT-110, INSPECTION, Low and Reverse Brake.>

9) Install 2-4 brake piston, retainer and return spring to transmission case. <Ref. to AT-101, INSTALLATION, 2-4 Brake.>

10) Install planetary gear and low clutch assembly to transmission case.

Install carefully while rotating the low clutch and planetary gear assembly slowly paying special attention not to damage the seal ring. <Ref. to AT-93, INSTALLATION, Planetary Gear and Low Clutch.>

11) Install the high clutch assembly. <Ref. to AT-88, INSTALLATION, High Clutch and Reverse Clutch.>

12) Install the oil pump housing assembly. <Ref. to AT-63, INSTALLATION, Oil Pump.>

13) Install the torque converter clutch case assembly to the transmission case assembly. <Ref. to AT-59, INSTALLATION, Torque Converter Clutch Case.>

14) Install reduction drive gear. <Ref. to AT-48, INSTALLATION, Reduction Drive Gear.>

15) Install reduction driven gear. WITHOUT VTD <Ref. to AT-48, WITHOUT VTD, INSTALLATION, Reduction Driven Gear.>

WITH VTD <Ref. to AT-49, WITH VTD, INSTALLATION, Reduction Driven Gear.>

16) Install the extension case to the transmission case. <Ref. to AT-36, INSTALLATION, Extension Case.>

17) Install the rear vehicle speed sensor.

**Tightening torque:**

**7 N·m (0.7 kgf·m, 5.1 ft·lb)**

18) Insert inhibitor switch and transmission connector into stay.

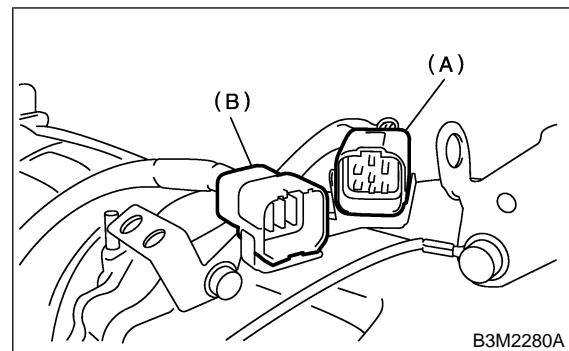

(A) Transmission harness  
(B) Inhibitor switch harness

19) Install air breather hose. <Ref. to AT-28, INSTALLATION, Air Breather Hose.>

20) Install the oil cooler pipes. <Ref. to AT-30, INSTALLATION, Oil Cooler Pipes.>

21) Install the oil charger pipe with O-ring. <Ref. to AT-29, INSTALLATION, Oil Charger Pipe.>

# LOW AND REVERSE BRAKE

Automatic Transmission

22) Insert the input shaft while turning lightly by hand.

### CAUTION:

Be careful not to damage the bushing.

**Normal protrusion A:**

**50 — 55 mm (1.97 — 2.17 in)**

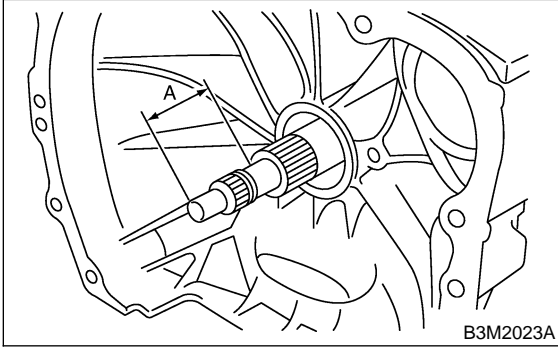

Available retaining plates	
Part No.	Thickness mm (in)
31667AA320	4.1 (0.161)
31667AA330	4.4 (0.173)
31667AA340	4.7 (0.185)
31667AA350	5.0 (0.197)
31667AA360	5.3 (0.209)
31667AA370	5.6 (0.220)
31667AA380	5.9 (0.232)

23) Install the torque converter clutch assembly.  
<Ref. to AT-35, INSTALLATION, Torque Converter Clutch Assembly.>

## C: INSPECTION

S510594A10

Check for the following.

- Drive plate facing for wear or damage
- Snap ring for wear and spring retainer for deformation

1) Inspect clearance and select retaining plate.

### NOTE:

Before measuring clearance, place the same thickness of shim on both sides to prevent retaining plate from tilting.

**Standard value:**

**0.7 — 1.2 mm (0.028 — 0.047 in)**

**Allowable limit:**

**2.2 mm (0.087 in)**

