

## 11. Rear Drive Shaft S510156

### A: REMOVAL S510156A18

- 1) Remove rear vehicle speed sensor and separate the extension case from the transmission case. <Ref. to AT-36, REMOVAL, Extension Case.>
- 2) Extract the rear drive shaft from the center differential assembly.

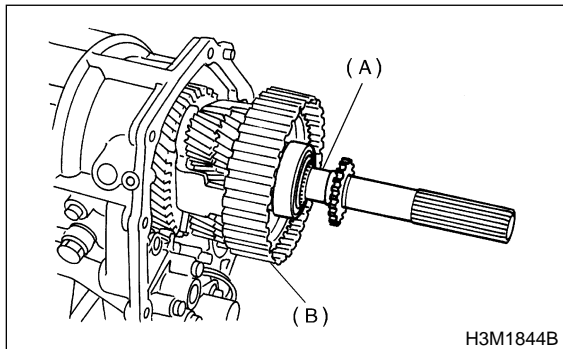

- (A) Rear drive shaft  
(B) Center differential carrier

- 3) Remove the drive plate and driven plate.

### B: INSTALLATION S510156A11

- 1) Install the drive plate and driven plate.
- 2) Insert the rear drive shaft into the center differential assembly.
- 3) Combine the transmission case with the extension case, and install the rear vehicle speed sensor. <Ref. to AT-36, INSTALLATION, Extension Case.>

### C: DISASSEMBLY S510156A06

- 1) Using a press, remove the revolution gear.

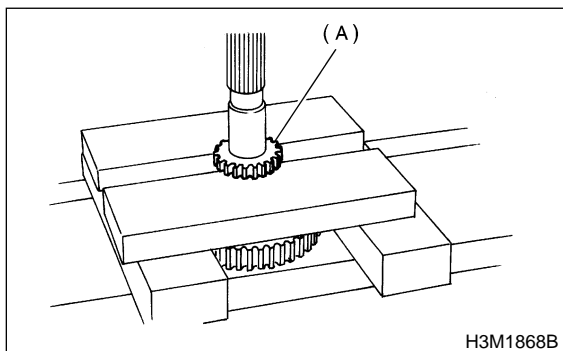

- (A) Revolution gear

- 2) Using a press, remove the front and rear side ball bearings and clutch hub.

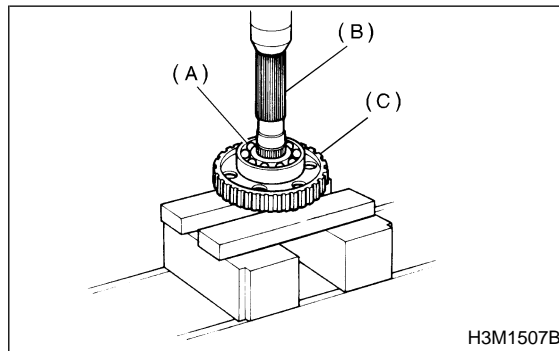

- (A) Rear ball bearing  
(B) Rear drive shaft  
(C) Clutch hub

### D: ASSEMBLY S510156A02

Assembly is in the reverse order of disassembly.

#### NOTE:

- Be sure to use a new ball bearings and revolution gear.
- Pay attention to the direction of the clutch hub.

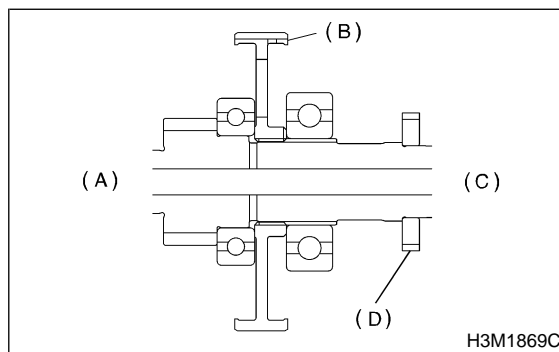

- (A) Front side  
(B) Clutch hub  
(C) Rear side  
(D) Revolution gear

### E: INSPECTION S510156A10

- Make sure that each component is free of harmful gouges, cuts, or dust.
- Measure the extension end play and adjust to within specifications. <Ref. to AT-44, WITH VTD, ADJUSTMENT, Transfer Clutch.>