

DIAGNOSTICS CHART WITH SYMPTOM

Cruise Control System (DIAGNOSTICS)

6. Diagnostics Chart with Symptom S003619

A: SYMPTOM CHART S003619F22

Symptom		Repair area	Reference
1	Cruise control main switch is not turned ON.	(1) Check power supply.	<Ref. to CC-14, CHECK POWER SUPPLY, Diagnostics Chart with Symptom.>
		(2) Check cruise control main switch.	<Ref. to CC-16, CHECK CRUISE CONTROL MAIN SWITCH, Diagnostics Chart with Symptom.>
2	Cruise control cannot be set.	(1) Check SET/COAST switch.	<Ref. to CC-19, CHECK CRUISE CONTROL COMMAND SWITCH, Diagnostics Chart with Symptom.>
		(2) Check stop light switch and brake switch.	<Ref. to CC-21, CHECK STOP LIGHT SWITCH AND BRAKE SWITCH, Diagnostics Chart with Symptom.>
		(3) Check clutch switch (MT).	<Ref. to CC-23, CHECK CLUTCH SWITCH (MT), Diagnostics Chart with Symptom.>
		(4) Check inhibitor switch (AT).	<Ref. to CC-25, CHECK INHIBITOR SWITCH (AT), Diagnostics Chart with Symptom.>
		(5) Check vehicle speed sensor.	<Ref. to CC-29, DTC 22 VEHICLE SPEED SENSOR, Diagnostics Chart with Trouble Code.>
		(6) Check motor drive system.	<Ref. to CC-33, DTC 35 AND 36 ACTUATOR MOTOR, Diagnostics Chart with Trouble Code.>
		(7) Check motor clutch drive system.	<Ref. to CC-35, DTC 37 ACTUATOR MOTOR CLUTCH, Diagnostics Chart with Trouble Code.>
3	Vehicle speed is not held within set speed ± 3 km/h (± 2 MPH).	(1) Check vehicle speed sensor.	<Ref. to CC-29, DTC 22 VEHICLE SPEED SENSOR, Diagnostics Chart with Trouble Code.>
		(2) Check motor drive system.	<Ref. to CC-33, DTC 35 AND 36 ACTUATOR MOTOR, Diagnostics Chart with Trouble Code.>
		(3) Check motor clutch drive system.	<Ref. to CC-35, DTC 37 ACTUATOR MOTOR CLUTCH, Diagnostics Chart with Trouble Code.>
4	Vehicle speed does not increase or does not return to set speed after RESUME/ACCEL switch has been pressed.	(1) Check RESUME/ACCEL switch.	<Ref. to CC-19, CHECK CRUISE CONTROL COMMAND SWITCH, Diagnostics Chart with Symptom.>
		(2) Check motor drive system.	<Ref. to CC-33, DTC 35 AND 36 ACTUATOR MOTOR, Diagnostics Chart with Trouble Code.>
		(3) Check motor clutch drive system.	<Ref. to CC-35, DTC 37 ACTUATOR MOTOR CLUTCH, Diagnostics Chart with Trouble Code.>
5	Vehicle speed does not decrease after SET/COAST switch has been pressed.	(1) Check SET/COAST switch.	<Ref. to CC-19, CHECK CRUISE CONTROL COMMAND SWITCH, Diagnostics Chart with Symptom.>
		(2) Check motor drive system.	<Ref. to CC-33, DTC 35 AND 36 ACTUATOR MOTOR, Diagnostics Chart with Trouble Code.>
		(3) Check motor clutch drive system.	<Ref. to CC-35, DTC 37 ACTUATOR MOTOR CLUTCH, Diagnostics Chart with Trouble Code.>

DIAGNOSTICS CHART WITH SYMPTOM

Cruise Control System (DIAGNOSTICS)

Symptom		Repair area	Reference
6	Cruise control is not released after CANCEL switch has been pressed.	(1) Check CANCEL switch.	<Ref. to CC-19, CHECK CRUISE CONTROL COMMAND SWITCH, Diagnostics Chart with Symptom.>
		(2) Check motor drive system.	<Ref. to CC-33, DTC 35 AND 36 ACTUATOR MOTOR, Diagnostics Chart with Trouble Code.>
		(3) Check motor clutch drive system.	<Ref. to CC-35, DTC 37 ACTUATOR MOTOR CLUTCH, Diagnostics Chart with Trouble Code.>
7	Cruise control is not released after brake pedal has been depressed.	(1) Check stop light switch and brake switch.	<Ref. to CC-21, CHECK STOP LIGHT SWITCH AND BRAKE SWITCH, Diagnostics Chart with Symptom.>
		(2) Check motor drive system.	<Ref. to CC-33, DTC 35 AND 36 ACTUATOR MOTOR, Diagnostics Chart with Trouble Code.>
		(3) Check motor clutch drive system.	<Ref. to CC-35, DTC 37 ACTUATOR MOTOR CLUTCH, Diagnostics Chart with Trouble Code.>
8	Cruise control is not released after clutch pedal has been depressed (MT).	(1) Check clutch switch.	<Ref. to CC-23, CHECK CLUTCH SWITCH (MT), Diagnostics Chart with Symptom.>
		(2) Check motor drive system.	<Ref. to CC-33, DTC 35 AND 36 ACTUATOR MOTOR, Diagnostics Chart with Trouble Code.>
		(3) Check motor clutch drive system.	<Ref. to CC-35, DTC 37 ACTUATOR MOTOR CLUTCH, Diagnostics Chart with Trouble Code.>

DIAGNOSTICS CHART WITH SYMPTOM

Cruise Control System (DIAGNOSTICS)

B: CHECK POWER SUPPLY S003619F23

TROUBLE SYMPTOM:

Cruise control can be set normally, but indicator does not come on. (When main switch is pressed.)

WIRING DIAGRAM:

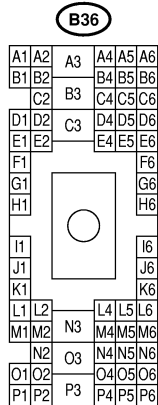
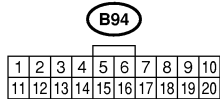
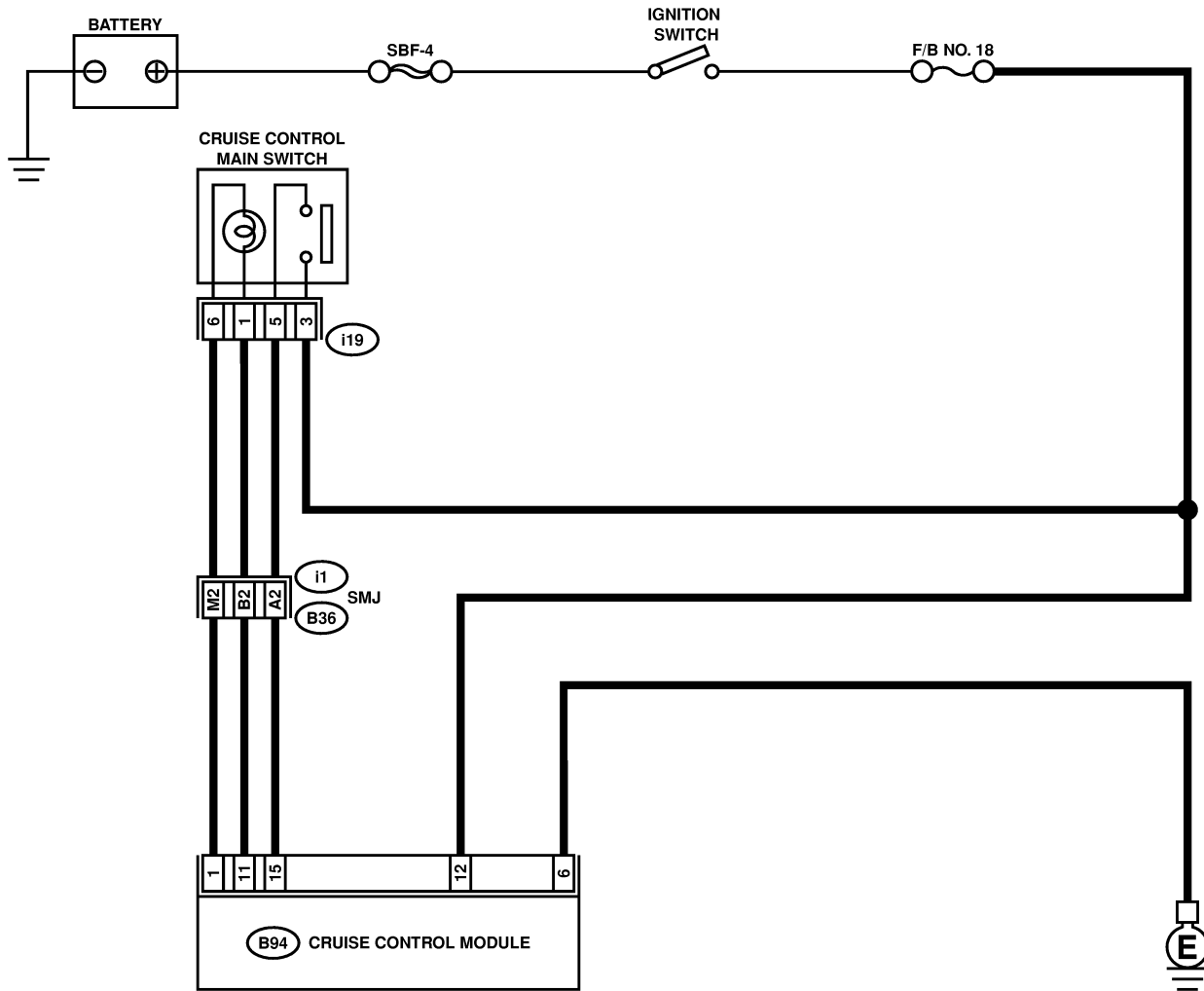

B6M1612

DIAGNOSTICS CHART WITH SYMPTOM

Cruise Control System (DIAGNOSTICS)

No.	Step	Check	Yes	No
1	<p>CHECK POWER SUPPLY.</p> <p>1) Turn ignition switch OFF. 2) Disconnect cruise control module harness connector. 3) Turn ignition switch ON. 4) Measure voltage between harness connector terminal and chassis ground.</p> <p>Connector & terminal (B94) No. 12 (+) — Chassis ground (-):</p>	Is the voltage more than 10 V?	Go to step 2.	<ul style="list-style-type: none"> ● Check fuse No. 18 (in fuse & relay box). ● Check harness for open or short between cruise control module and fuse & relay box.
2	<p>CHECK GROUND CIRCUIT.</p> <p>1) Turn ignition switch OFF. 2) Measure resistance between harness connector terminal and chassis ground.</p> <p>Connector & terminal (B94) No. 6 (+) — Chassis ground (-):</p>	Is the resistance less than 10 Ω?	Power supply and ground circuit are OK.	Repair harness.

DIAGNOSTICS CHART WITH SYMPTOM

Cruise Control System (DIAGNOSTICS)

C: CHECK CRUISE CONTROL MAIN SWITCH S003619F24

TROUBLE SYMPTOM:

Cruise control main switch is not turned ON and cruise control cannot be set.

NOTE:

When the main relay (built-in cruise control module) operates, the main switch circuit is in normal condition.

The main relay operation can be checked by hearing the operation sounds.

This operation sounds will be heard when ignition switch and cruise control main switch are turned to ON.

DIAGNOSTICS CHART WITH SYMPTOM

Cruise Control System (DIAGNOSTICS)

WIRING DIAGRAM:

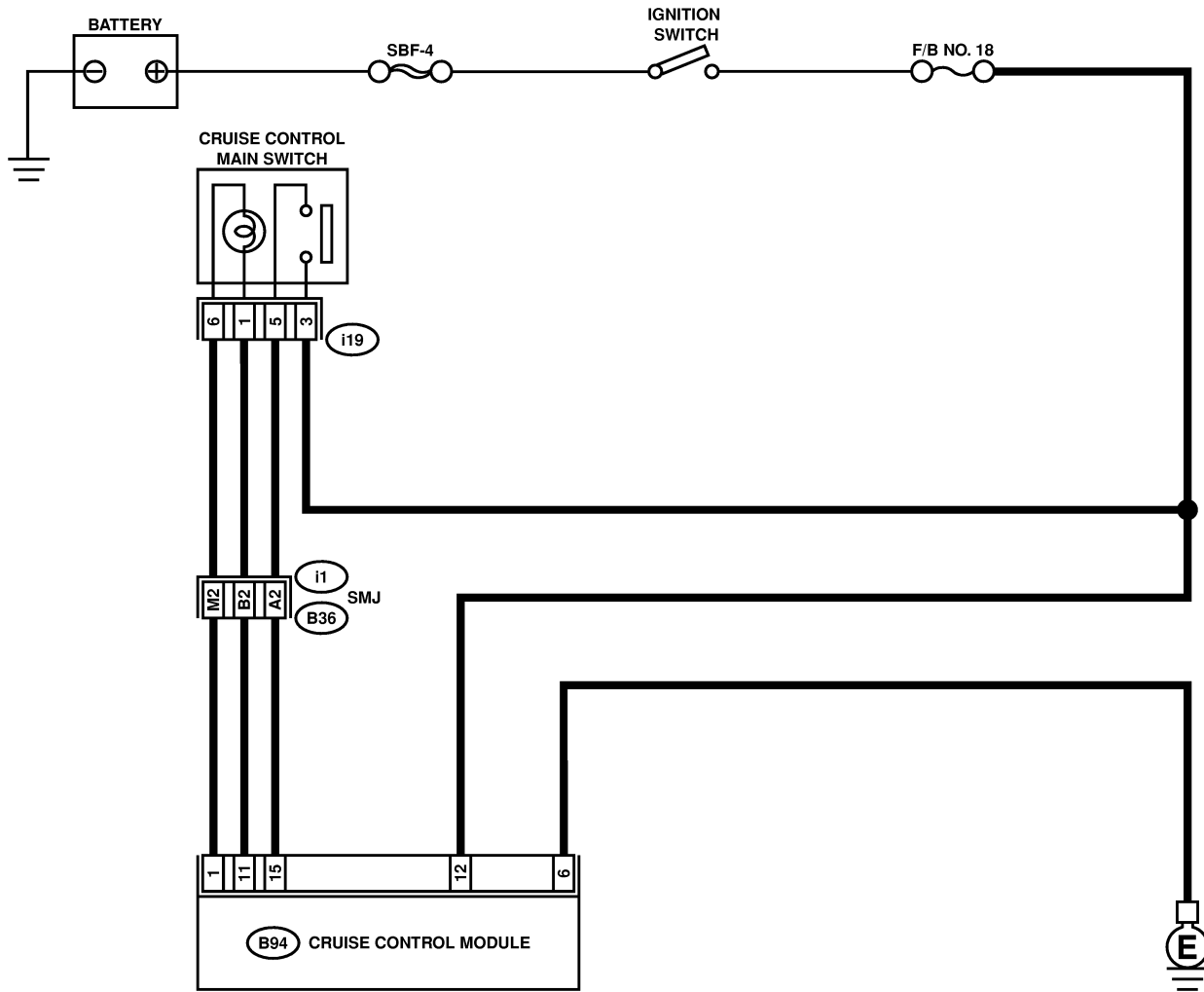

i19

1	2
3	6

B94

1	2	3	4	5	6	7	8	9	10
11	12	13	14	15	16	17	18	19	20

B36

A1	A2	A3	A4	A5	A6
B1	B2	B3	B4	B5	B6
C1	C2	C3	C4	C5	C6
D1	D2	D3	D4	D5	D6
E1	E2	E3	E4	E5	E6
F1	F2	F3	F4	F5	F6
G1	G2	G3	G4	G5	G6
H1	H2	H3	H4	H5	H6
I1	I2	I3	I4	I5	I6
J1	J2	J3	J4	J5	J6
K1	K2	K3	K4	K5	K6
L1	L2	L3	L4	L5	L6
M1	M2	M3	M4	M5	M6
N1	N2	N3	N4	N5	N6
O1	O2	O3	O4	O5	O6
P1	P2	P3	P4	P5	P6

B6M1612

DIAGNOSTICS CHART WITH SYMPTOM

Cruise Control System (DIAGNOSTICS)

No.	Step	Check	Yes	No
1	CHECK CRUISE CONTROL MAIN SWITCH CIRCUIT. 1) Turn ignition switch OFF. 2) Disconnect cruise control main switch harness connector. 3) Turn ignition switch ON. 4) Measure voltage between harness connector terminal and chassis ground. Connector & terminal (i19) No. 3 (+) — Chassis ground (-):	Is the voltage more than 10 V?	Go to step 2.	<ul style="list-style-type: none"> ● Check fuse No. 18 (in fuse & relay box). ● Check harness for open or short between cruise control main switch and fuse & relay box.
2	CHECK CRUISE CONTROL MAIN SWITCH CIRCUIT. 1) Turn ignition switch OFF. 2) Disconnect cruise control module harness connector. 3) Measure resistance between cruise control module harness connector terminal and cruise control main switch harness connector terminal. Connector & terminal (B94) No. 15 (+) — (i19) No. 5 (-): (B94) No. 1 (+) — (i19) No. 6 (-): (B94) No. 11(+) — (i19) No. 1 (-):	Is the resistance less than 10 Ω?	Go to step 3.	Repair harness.
3	CHECK CRUISE CONTROL MAIN SWITCH. Remove and check cruise control main switch. <Ref. to CC-5, Cruise Control Main Switch.>	Is cruise control main switch OK?	Replace cruise control module.	Replace cruise control main switch.

DIAGNOSTICS CHART WITH SYMPTOM

Cruise Control System (DIAGNOSTICS)

D: CHECK CRUISE CONTROL COMMAND SWITCH S003619F25

TROUBLE SYMPTOM:

Cruise control cannot be set. (Cancelled immediately.)

WIRING DIAGRAM:

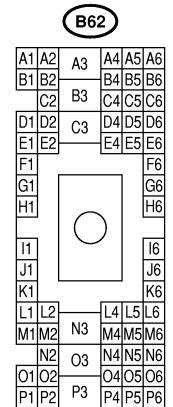
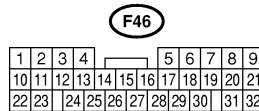
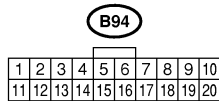
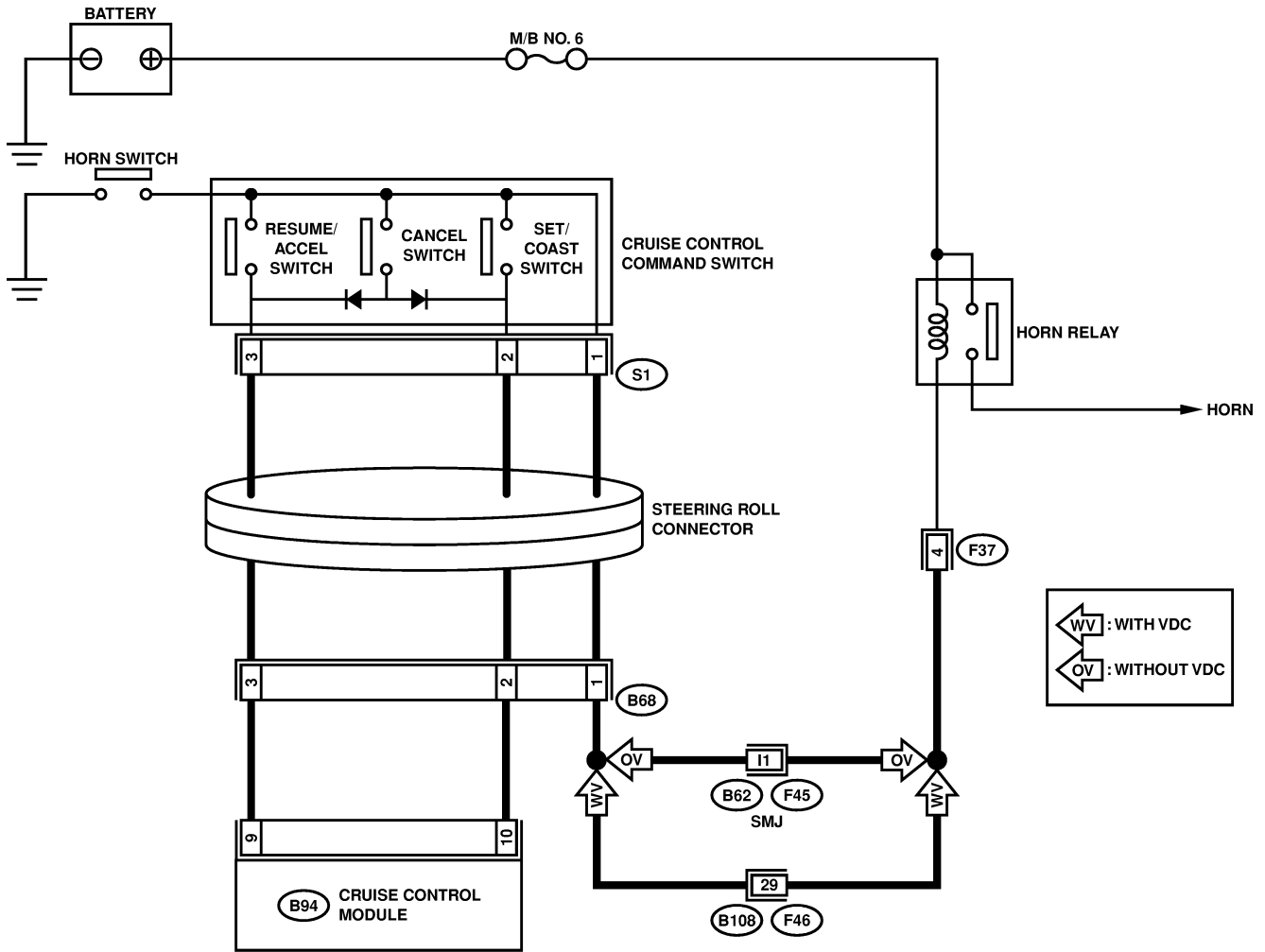

B6M1613

DIAGNOSTICS CHART WITH SYMPTOM

Cruise Control System (DIAGNOSTICS)

No.	Step	Check	Yes	No
1	CHECK SET/COAST SWITCH CIRCUIT. 1) Turn ignition switch OFF. 2) Disconnect cruise control module harness connector. 3) Measure voltage between harness connector terminal and chassis ground when SET/COAST switch is pressed and not pressed. Connector & terminal (B94) No. 10 (+) — Chassis ground (-):	Is the voltage 0 V when SET/COAST switch is not pressed? Is the voltage more than 10 V when SET/COAST switch is pressed?	Go to step 2.	Go to step 4.
2	CHECK RESUME/ACCEL SWITCH CIRCUIT. Measure voltage between harness connector terminal and chassis ground when RESUME/ACCEL switch is pressed and not pressed. Connector & terminal (B94) No. 9 (+) — Chassis ground (-):	Is the voltage 0 V when RESUME/ACCEL switch is not pressed? Is the voltage more than 10 V when RESUME/ACCEL switch is pressed?	Go to step 3.	Go to step 4.
3	CHECK CANCEL SWITCH CIRCUIT. Measure voltage between harness connector terminal and chassis ground when CANCEL switch is pressed and not pressed. Connector & terminal (B94) No. 9 (+) — Chassis ground (-): (B94) No. 10 (+) — Chassis ground (-):	Is the voltage 0 V when CANCEL switch is not pressed? Is the voltage more than 10 V when CANCEL switch is pressed?	Cruise control command switch circuit is OK.	Go to step 4.
4	CHECK POWER SUPPLY FOR COMMAND SWITCH. Check horn operation.	Does horn sound?	Go to step 5.	<ul style="list-style-type: none"> ● Check fuse No. 6 (in main fuse box). ● Check horn relay. <Ref. to COM-4, HORN RELAY, INSPECTION, Horn System.> ● Check harness for open or short between cruise control command switch and fuse & relay box.
5	CHECK CRUISE CONTROL COMMAND SWITCH. Remove and check cruise control command switch. <Ref. to CC-6, Cruise Control Command Switch.>	Is cruise control command switch OK?	Check harness between cruise control command switch and cruise control module.	Replace cruise control command switch.

DIAGNOSTICS CHART WITH SYMPTOM

Cruise Control System (DIAGNOSTICS)

E: CHECK STOP LIGHT SWITCH AND BRAKE SWITCH

S003619F26

TROUBLE SYMPTOM:

Cruise control cannot be set.

WIRING DIAGRAM:

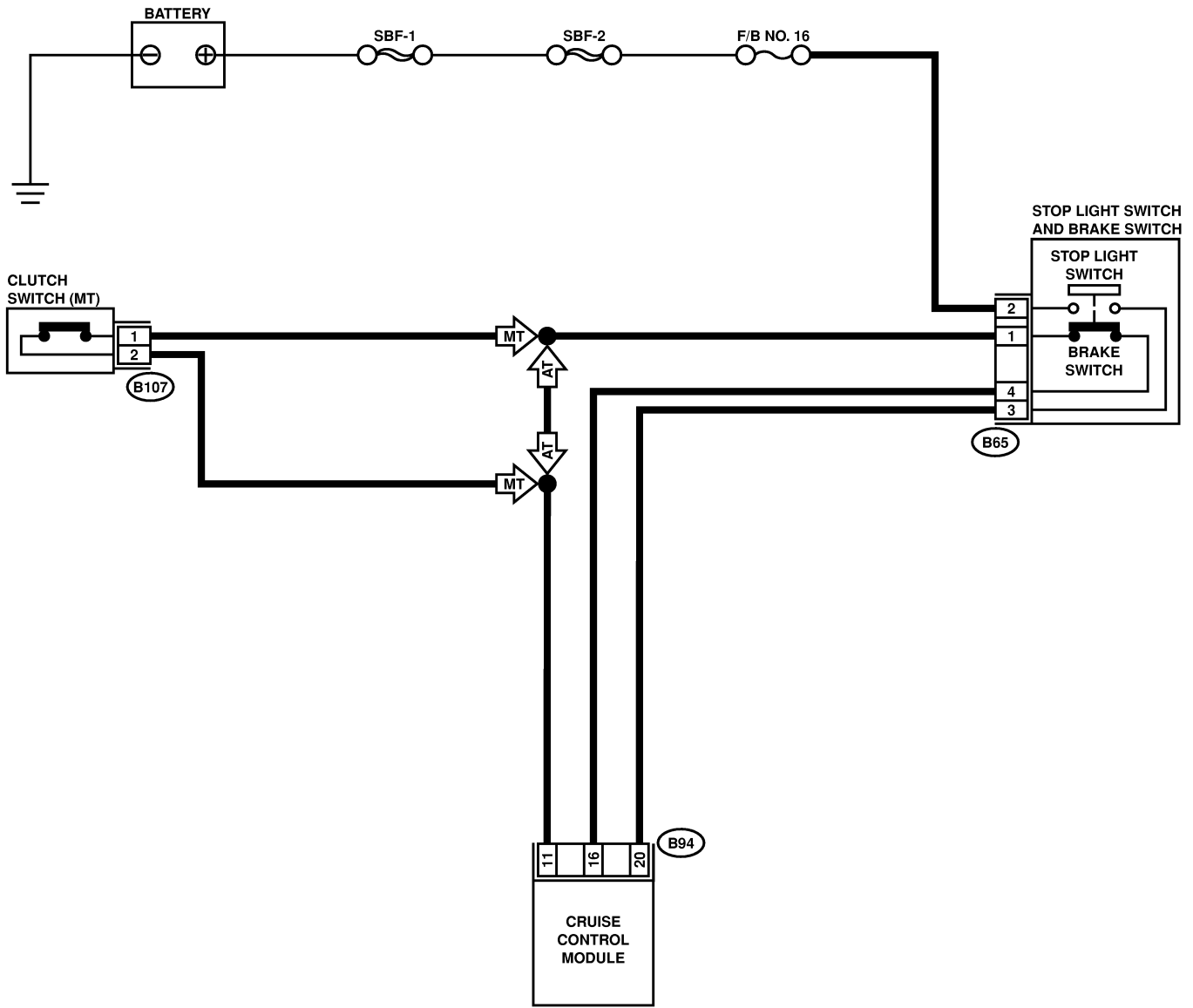

B107



B65



B94

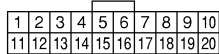

B6M1614

DIAGNOSTICS CHART WITH SYMPTOM

Cruise Control System (DIAGNOSTICS)

No.	Step	Check	Yes	No
1	<p>CHECK STOP LIGHT SWITCH AND BRAKE SWITCH CIRCUIT.</p> <p>1) Turn ignition switch OFF. 2) Disconnect stop light switch and brake switch harness connector. 3) Turn ignition switch ON. 4) Turn cruise control main switch ON. 5) Measure voltage between harness connector terminal and chassis ground.</p> <p>Connector & terminal <i>(B65) No. 2 (+) — Chassis ground (-):</i></p>	Is the voltage more than 10 V?	Go to step 2.	<ul style="list-style-type: none"> ● Check fuse No. 16 (in fuse & relay box). ● Check harness for open or short between stop light/brake switch and fuse & relay box.
2	<p>CHECK STOP LIGHT SWITCH AND BRAKE SWITCH CIRCUIT.</p> <p>Measure voltage between harness connector terminal and chassis ground.</p> <p>Connector & terminal <i>(B65) No. 1 (+) — Chassis ground (-):</i></p>	Is the voltage more than 10 V?	Go to step 3.	<ul style="list-style-type: none"> ● Check harness for open or short between stop light/brake switch and cruise control module (AT). ● Check clutch switch and the circuit (MT).
3	<p>CHECK STOP LIGHT SWITCH AND BRAKE SWITCH CIRCUIT.</p> <p>1) Turn cruise control main switch and ignition switch OFF. 2) Disconnect cruise control module harness connector. 3) Measure resistance between cruise control module harness connector terminal and stop light switch and brake switch harness connector terminal.</p> <p>Connector & terminal <i>(B94) No. 20 (+) — (B65) No. 3 (-):</i> <i>(B94) No. 16 (+) — (B65) No. 4 (-):</i></p>	Is the resistance less than 10 Ω?	Go to step 4.	Repair harness.
4	<p>CHECK STOP LIGHT SWITCH AND BRAKE SWITCH.</p> <p>Remove and check stop light switch and brake switch. <Ref. to CC-7, Stop and Brake Switch.></p>	Is stop light switch and brake switch OK?	Stop light switch and brake switch circuit are OK.	Replace stop light switch and brake switch.

DIAGNOSTICS CHART WITH SYMPTOM

Cruise Control System (DIAGNOSTICS)

F: CHECK CLUTCH SWITCH (MT) S003619F27

TROUBLE SYMPTOM:

Cruise control cannot be set.

WIRING DIAGRAM:

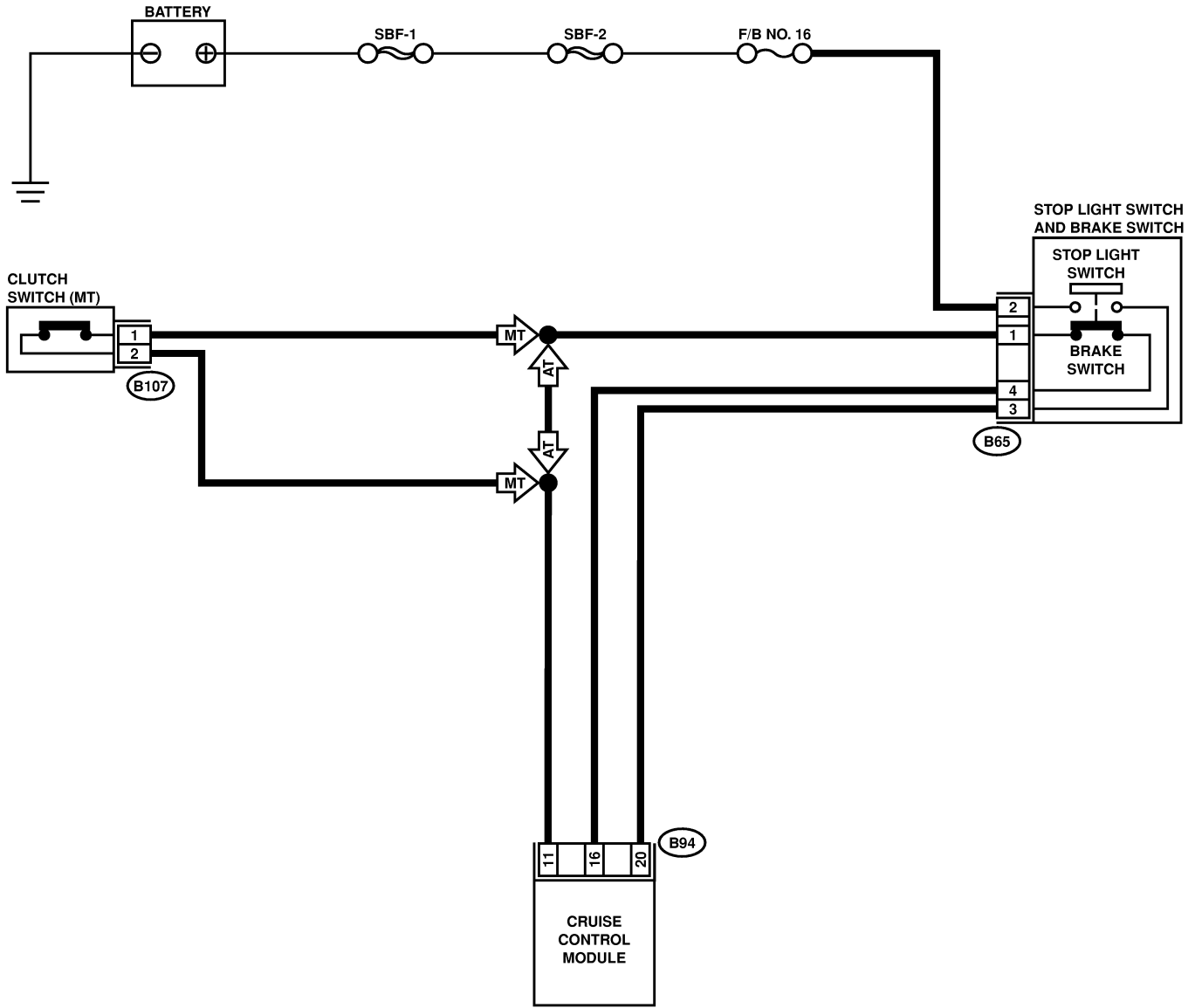

B107



B65



B94

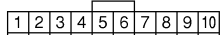

B6M1614

DIAGNOSTICS CHART WITH SYMPTOM

Cruise Control System (DIAGNOSTICS)

No.	Step	Check	Yes	No
1	CHECK CLUTCH SWITCH CIRCUIT. 1) Turn ignition switch OFF. 2) Disconnect clutch switch harness connector. 3) Turn ignition switch ON. 4) Turn cruise control main switch ON. 5) Measure voltage between harness connector terminal and chassis ground. Connector & terminal (B107) No. 2 (+) — Chassis ground (-):	Is the voltage more than 10 V?	Go to step 2.	Check harness for open or short between clutch switch and cruise control module.
2	CHECK CLUTCH SWITCH CIRCUIT. 1) Turn cruise control main switch and ignition switch OFF. 2) Disconnect stop light switch and brake switch harness connector. 3) Measure resistance between clutch switch harness connector terminal and stop light switch and brake switch harness connector terminal. Connector & terminal (B107) No. 1 (+) — (B65) No. 1 (-):	Is the resistance less than 10 Ω?	Go to step 3.	Repair harness.
3	CHECK CLUTCH SWITCH. Remove and check clutch switch. <Ref. to CC-8, Clutch Switch.>	Is clutch switch OK?	Clutch switch circuit is OK.	Replace clutch switch.

DIAGNOSTICS CHART WITH SYMPTOM

Cruise Control System (DIAGNOSTICS)

G: CHECK INHIBITOR SWITCH (A/T) S003619F28

TROUBLE SYMPTOM:

Cruise control cannot be set.

WIRING DIAGRAM:

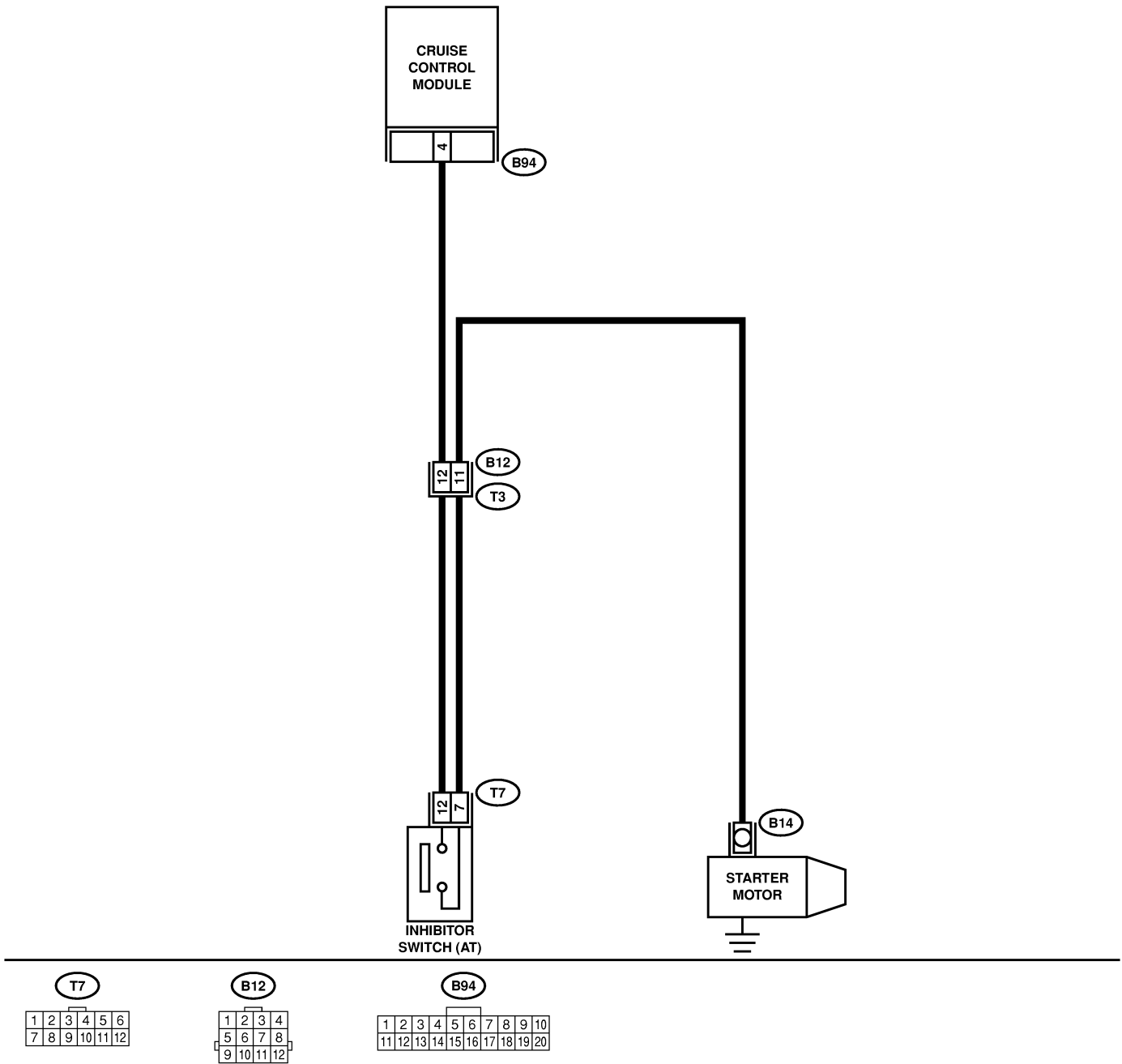

B6M1527

DIAGNOSTICS CHART WITH SYMPTOM

Cruise Control System (DIAGNOSTICS)

No.	Step	Check	Yes	No
1	CHECK INHIBITOR SWITCH CIRCUIT. 1) Turn ignition switch OFF. 2) Disconnect inhibitor switch harness connector. 3) Turn ignition switch ON. 4) Turn cruise control main switch ON. 5) Measure voltage between harness connector terminal and chassis ground. Connector & terminal (T7) No. 12 (+) — Chassis ground (-):	Is the voltage more than 10 V?	Go to step 2.	Check harness for open or short between inhibitor switch and cruise control module.
2	CHECK INHIBITOR SWITCH CIRCUIT. 1) Turn cruise control main switch and ignition switch OFF. 2) Disconnect starter motor harness connector. 3) Measure resistance between inhibitor switch harness connector terminal and chassis ground. Connector & terminal (T7) No. 7 (+) — (B14) No. 1 (-):	Is the resistance less than 10 Ω?	Go to step 3.	Repair harness.
3	CHECK INHIBITOR SWITCH. Remove and check inhibitor switch. <Ref. to CC-9, Inhibitor Switch.>	Is inhibitor switch OK?	Inhibitor switch circuit is OK.	Replace inhibitor switch.